



X-LARGE VOLUME DEEP FRYER - AUTO-LIFT -
FILTER SYSTEM - ELECTRIC OPERATION -
TOUCHSCREEN CONTROLS - TRAINING CENTRAL™

Model BLF-TC



This extra-large, electric auto-lift fryer is designed for simple operation, long life, and high product volume. Open-vat fryers are perfect for producing extra-crispy exteriors and tender interiors on a variety of fried foods. Combine this fryer with a BKI warmer, and your food will be hot and crispy for hours!

The BKI® TC series of high-volume deep fryers now feature touchscreen controls with our new, signature Training Central™. In minutes, new employees will be managing virtually every operation—programming, cooking, cleaning, filtering, boiling out, and more—simply by following intuitive, step-by-step screen instructions that provide instant feedback. Training Central reduces time spent on employee training and retraining to save you money.

Heating elements are completely submerged in oil inside the vat to maximize efficiency and speed recovery times. The auto-lift basket ensures that food is removed from the oil at the precise moment it is completely cooked. The auto-lift feature also keeps employees away from hot, splattering oil.

A cold zone in the vat collects breading fall-off to keep oil fresh, while the built-in filtration system extends oil life to save you money and produce consistent results. The patented quickdisconnect allows for easy removal of the vat, so filtering oil is easy and safe.

FEATURES AT A GLANCE

- 7" LCD touchscreen controls with Training Central
- USB for uploading recipes
- Heavy-duty, aluminum oil vat lid with rolled edges
- 24 lb (10.8 kg) product with optional grande basket, with a
- 75 lb (34 kg) oil capacity
- Electric operation
- 5" casters for easy mobility
- Auto-lift basket for precise cooking
- Stainless steel construction
- Built-in filtration
- Assembled in USA

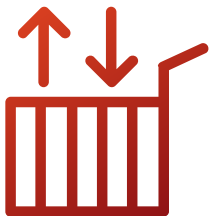

AUTO-LIFT BASKET

The auto-lift basket feature pulls the product from the oil when the cook cycle is complete.



ELECTRIC OPERATION

Energy efficiency and easy installation are a perfect pairing for your food service operation.



TOUCHSCREEN CONTROLS

Intuitive touchscreen controls feature the Training Central.

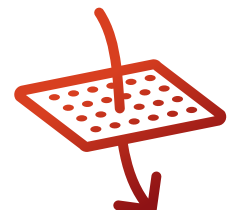

SEMI-AUTO FILTRATION

Automatic filtration system filters after every batch without operator input.

www.bkideas.com

42 Allen Martin Drive, Essex Junction, VT 05452 • Phone: (802) 658-6600 • Fax: (802) 864-0183

BK1264 Rev B (7/21)

EQUIPMENT DIMENSIONS

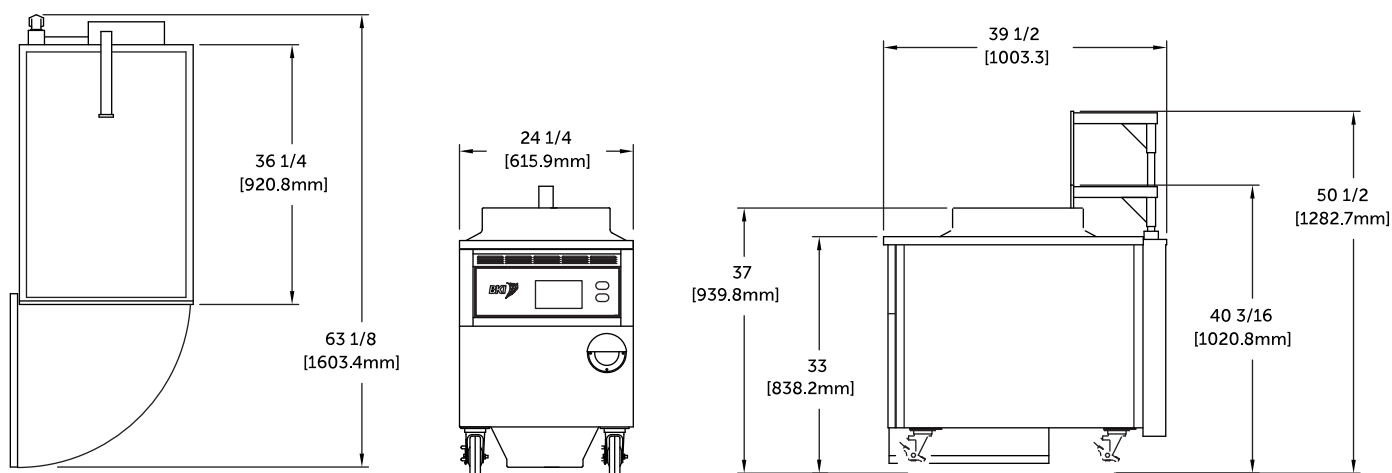

MECHANICAL SPECIFICATIONS

Dimensions	Uncrated	Crated
Height	40 3/16" (1020.8 mm)	60" (1524 mm)
Width	24 1/4" (615.9 mm)	31" (787 mm)
Depth	39 1/2" (1003.3 mm)	45" (1143 mm)
Floor space	6.7 sq ft (.62 sq m)	7.9 sq ft (.73 sq m)
Weight	325 lb (147.4 kg)	335 lb (152 kg)

ELECTRICAL OPTIONS

Volts	Amps	Breaker	kW	Wires	Phase
208	47.3	60	17	3	3
240	41	50	17	3	3
220/380	21.7	30	14.3	4	3
230/240	22.8	30	15.6	4	3
240/415	23.7	30	17	4	3

INCLUDED ACCESSORIES

- Bail handle basket
- 1 L-tipped brush
- 1 White drain brush
- 1 Pair 13" insulated mitts
- Package of five filter papers
- High-flow oil pump

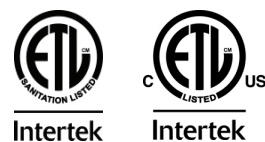

Visit www.bkideas.com to view all accessories available with this model.