

APPLICATION:

PRODUCT NAME:
ADPTR SVL VB 1/4

JOB NAME:

SPECIAL CONFIGURATION
CHECK BASE MODEL AND OPTIONS

QUANTITY:

ITEM NO.

MODEL:
 2932

OPTIONS OR MODIFICATIONS:
 OTHER _____

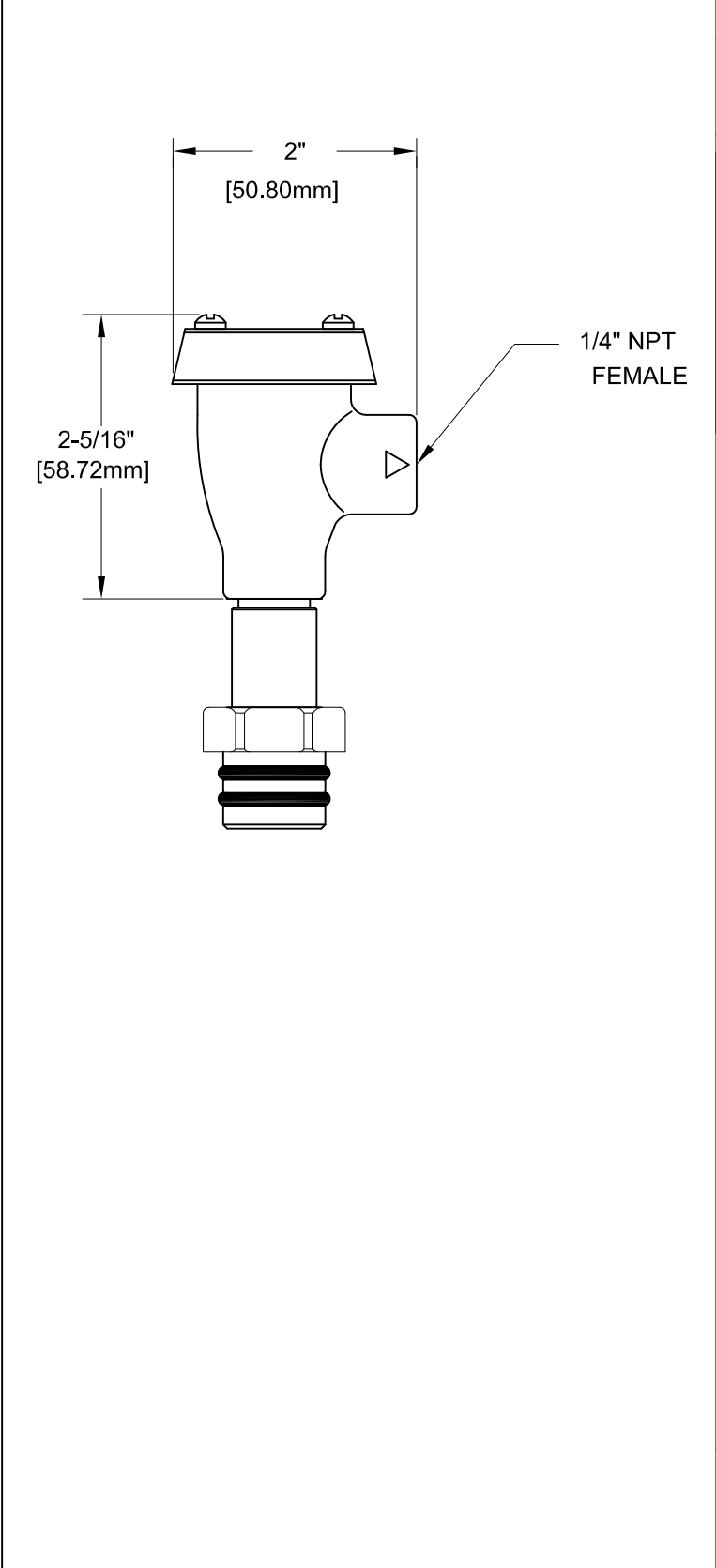

FEATURES:

- * 1/4" F INLET AND OUTLET
- * 2.2 GPM MAX. AT 80 PSI
- * POLISHED CHROME FINISH

SYSTEM LIMITS

- * TEMP: 40°F MIN. TO 160°F MAX.
- * PRESSURE 100 PSI MAX. STATIC

SHIPPING WEIGHT

- * 0.6 LBS



FISHER MANUFACTURING COMPANY
 TOLL FREE: 800-421-6162 - FAX: 800-832-8238
 information@fisher-mfg.com - www.fisher-mfg.com