



U.S. Patented Safety Illumination
US 9,827,689 B2

BIZERBA

Food Service

Bizerba GSP series slicers are certified to the new NSF/ANSI Standard 8-2017

... GSP H i 90 series – manual safety slicer ...

Award winning - safety illuminated dial!

- Energy Efficiency: 1/2 H.P. motor, 319 r.p.m.
- High Yield: Operating time, designed for permanent operation
- High Yield: Unique carriage-shifting design allows for the smallest end pieces, increased product yield
- High Yield: Widest product carriage for increased capacity
- High Yield: Heavy-duty, 3 lb. blade knife cover, durable
- High Yield: Debris deflector, permanently mounted, included
- High Yield: Precision machined pencil-point-grooves on gauge plate, blade cover and carriage to reduce friction, produce better looking product
- Safety Interlock: No-volt release
- Safety Interlock: Adjustable blade shut off settings: 15, 30, 45 seconds or off
- Safety Interlock: Shut off in slice thickness knob
- Safety Interlock: Carriage and gauge plate lock during the cleaning process
- Safety Interlock: Forced start with slice thickness knob below zero
- Operator Safety: Slicer installation, start-up and training, included
- Operator Safety: Illuminated index slicing dial, at-a-glance machine status:
 - green - safe for cleaning
 - flashing red - blade exposed, close gauge plate before cleaning
 - solid red - proceed with caution, ready to slice
- Operator Safety: Green push-handle on carriage, safe slicing
- Operator Safety: Red remnant-lift arm handle, reminds operator to use caution
- Operator Safety: 3.5"W (90mm) x 9.13"H x 2.6"D thumb guard wall for maximum protection
- Operator Safety: 360° blade enclosure, no top-gaps in blade ring-guard
- Operator Safety: Zero blade exposure during the cleaning process
- Operator Safety: Front mounted controls
- Operator Safety: Rear mounted lift arm with largest and easiest to use remnant holder with 306 holding points, removable for cleaning, dish-machine safe
- Operator Safety: Low profile carriage for easy loading of heavy product
- Operator Safety: Side lift arm for easy cleaning under slicer
- Operator Safety: Recommended 31.25" - above floor height
- Food Safety: One piece anodized aluminum construction
- Food Safety: Non-removable carriage system for faster cleaning and sanitizing
- Food Safety: Double-sided seal between blade knife and housing, no gap for food to collect, better hygiene
- Food Safety: UL157 dairy grade seals and gaskets used to seal against water and food debris, no silicone used under seals, better hygiene
- Food Safety: Liquid and debris diversion from all control surfaces
- Food Safety: Remote blade sharpener does not collect food debris during operation and is dishwasher safe for improved safety and hygiene
- Food Safety: One piece carriage with seamless thumb guard for highest hygiene standards, no slotted-screw heads on thumb guard
- One Year Warranty: On-site, labor and parts

Best blade in the industry

The unique design of our blade produces clean and consistent slices. The hardness results in a long lasting sharp edge. The life of the blade is dramatically longer than the competition. Our standard blade is the hardest, thinnest, largest, straightest blade in the industry.

- 13" diameter, chromium coated hard alloy
- 60-62 Rockwell hardness at the edge



BIM | CAD | MOBILE

Gauge plate closed, safe for cleaning - green.



Gauge plate open and motor running, ready to slice - solid red.



Model #: GSP H i 90 |

Stock #: 913003019

C.S.I. Division 11 | Section 4000

Project Name: _____ AIA # _____

Location: _____ SIS # _____

Item Number: _____

Quantity: _____

BIZERBA

Food Service

1-phase AC current

- 120 V, specialised data available on request
- 60 Hz
- Frequency of nominal current 3.5 A
- Power consumption 0.360 kW

Blade diameter

- 13" (330 mm)

Blade speed

- 319 r.p.m.

Max. produce size

- Height: 4.96" (126 mm)
- Width: 11.6" (290 mm)
- Round: 8" (200 mm)
- Rectangular: 11.6 x 6.4" (290 x 160 mm)

Slice thickness

- 0-0.94" (0-24 mm), infinitely variable

Thumb-guard rear wall

- 3.5"W x 11.13"H x 2.6"D (90 x 235 x 67 mm)

Gravity-feed slicing carriage

- 40° inclined gravity feed

H - Carriage inclination

- Carriage inclined 25° towards operator
- Carriage height positioned towards center of blade

Noise control drive system

- 58 dB decibel level

Installation area

- (L x W) 20.94" x 18.82" (530 x 480 mm)

External dimensions

- (L x W x H) 28.54" x 23.07" x 23.46"
- 725 x 586 x 596 mm

Operating area

- (L x W) 31.73" x 35.4" (806 x 899 mm)

Food Safety - Ingress Protection type

- IP Solids level 3 | Liquids level 3

Weight of machine

- 95.1 lbs, 43 kg

Shipping Details & Dimensions

- Total Shipping Dimensions (L x W x H): 32.5" x 27.8" x 32" (826 x 706 x 813 mm)
- Total Shipping Weight: 124 lbs, 56.3 kg
- Cubic: Ft. 16.73, 0.47 m
- Density: 7.41 lb/cubic ft, 118.95 kg/cubic m

Additional equipment

- Food Vegetable Chute 7" Dia. x 12"L (178x350mm), stomper weight is 3 lb. (1.36kg), easy-glide
- Equipment Stand
- Extended Warranty
- 13" (330 mm) Grooved Cheese Blade



Remote sharpener, better food safety

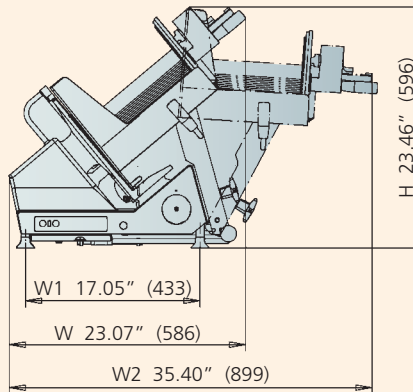
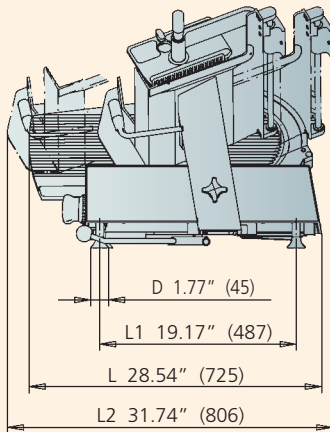

Warranty

The GSP H Safety Slicer carries a one-year, on-site parts and labor warranty against any flaws in materials and workmanship. This period begins with the date of purchase and, provided the unit is used properly in accordance with our instructions, is in full effect for one year from that date. Any work to be performed under this warranty must be performed between the hours of 8:00 a.m. and 4:30 p.m. local time, Monday to Friday. Bizerba will not pay overtime charges for work performed other than during normal business hours. Accessories have a 30-day replacement or repair warranty for the period beginning on the date of purchase. Damages incurred in transit or from installation error, accident, alteration or misuse are not covered. Transit damages should be reported to the carrier immediately. Bizerba shall not be liable for any consequential, compensatory, incidental, or special damages. All warranty work must be performed by a factory authorized Bizerba Representative.

Members of the Bizerba Group

Bizerba GmbH & Co. KG
 Wilhelm-Kraut-Straße 65
 72336 Balingen
 Germany
 Tel. +49 7433 12-0
 Fax +49 7433 12-2696
 marketing@bizerba.de
 www.bizerba.com

Bizerba USA Inc.
 1804 Fashion Court
 Joppa, MD 21085
 USA
 Tel. Office +1 732 565-6000
 Tel. Service +1 732 565-6001
 Fax +1 732 819-0429
 us.foodservice@bizerba.com
 www.bizerba.com

Bizerba Canada Inc.
 6411 Edwards Blvd.
 Mississauga, Ontario L5T2PT
 Canada
 Tel. +1 888 240-3722
 French Tel. +1 877 699-2199
 Fax +1 905 816-0497
 ca.info@bizerba.com
 www.bizerba.ca

Bizerba de México, S.A. de
 C.V. Av. Rio Mixcoac No. 157
 Colonia Florida
 01030 México, D.F.
 México
 Tel. +52 55 5663-1397
 Fax +52 55 5663-1296
 contacto@bizerba.com.mx
 www.bizerba.com.mx

