



BEVERAGE-AIR

Project: _____	AIA#
Item: _____	
Location: _____	SIS#
Approved: _____	

NC51HC NOVELTY FREEZER: SLANT TOP BUNKERS

NC NOVELTY CASES
 NC51HC Novelty Freezers
 Hydrocarbon Series

MODEL:
NC51HC-1-W



7 Year Parts/Labor Warranty
7 Year Compressor Warranty

CABINET CONSTRUCTION

- Exterior is white coated steel
- Interior is white powder coated surface
- Low energy consumption
- LED lighting
- Adjustable thermostat
- Operating temperature of 0°F to -10°F
- Angle top design with LowE tempered glass lids
- Lids are easily removable with lid lock & keys standard
- Round exterior edges
- Integrated tag molding
- 2" Heavy duty casters
- Drain plug for easy cleaning
- Five (5) removable baskets

OPTIONS & ACCESSORIES

- 2 Ring tub holder
- Custom graphics
- Dip well

REFRIGERATION SYSTEM

- Refrigeration system uses R290 refrigerant to comply with all environmental concerns
- The unit is best suited for an environment where temperatures remain below 75°F and humidity does not exceed 55%
- Areas with direct sunlight should also be avoided



Please verify qualifying units by visiting:
www.energystar.gov/cfs

3779 Champion Blvd., Winston-Salem, NC 27105
 1-888-845-9800 Fax: 1-336-245-6453
 Beverage-Air.com Sales@bevair.com



BEVERAGE-AIR

MODEL	NC51HC-1-W
EXTERNAL DIMENSIONAL DATA	
Width Overall	50 7/8"
Depth Overall	26"
Height Overall (with casters)	34 1/8"
Number of Lids	2
Number of Baskets	5
INTERNAL DIMENSIONAL DATA	
NET Capacity (cubic ft.)	9.43
Internal Width Overall (in)	44 1/16"
Internal Depth Overall (in)	19 7/16"
Internal Front Height Overall (in)	24"
Internal Rear Height Overall (in)	26 1/8"
ELECTRICAL DATA	
Full Load Amperes 115/60/1	3.5
REFRIGERATION DATA	
Horsepower	1/4
Capacity (BTU/Hr)	1130
Heat Rejection (BTU/Hr)	1695
Charge (lbs/grams)	0.198/90
SHIPPING DATA	
Gross Weight - Crated	184 lbs
Height - Crated	40"
Width - Crated	52"
Depth - Crated	28"

We reserve the right to change specifications and product design without notice. Such revisions do not entitle the buyer to corresponding changes, improvements, additions or replacements for previously purchased equipment. Dimensional tolerances +/- 1/4". Metric dimensions (MM).

Novelty Case Freezer Model: NC51HC-1-W

Model Views

Required Clearance: 4" Sides & Rear

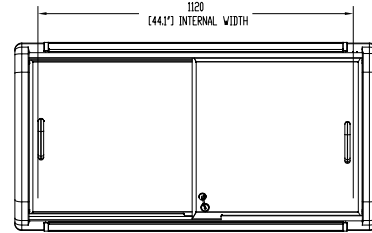

PLAN VIEW

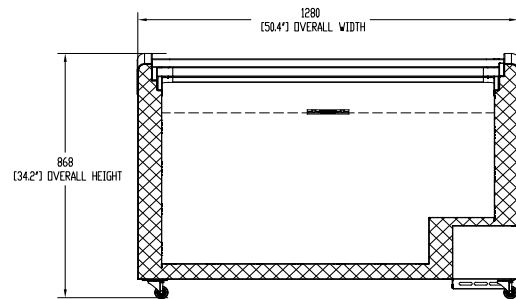

ELEVATION VIEW

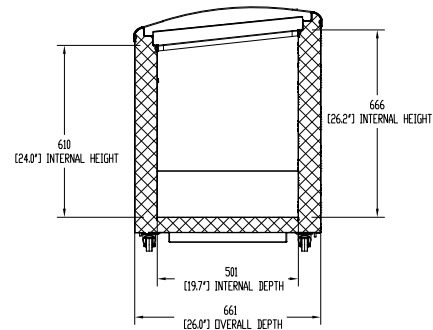

SIDE VIEW



ELECTRICAL CONNECTION



115/60/1
NEMA 5-15P

Units pre-wired at factory and include 8' long cord and plug set.