

BACK BAR EQUIPMENT

Model: **BB79SNPT**

Natural Refrigerant R-290 Model

79" Back Bar Cooler Shallow Depth, Pass-Thru

Textured baked black enamel finish exterior, stainless steel countertop, interior back and side panels with reinforced stainless steel floor.



Options and Accessories

(upcharge and lead times may apply)

Additional epoxy coated shelves	Condensing unit on right
Stainless steel shelves	Wine rack
Food storage rated stainless steel interior (NSF-7)	Castors or legs
Riser base* (field installed)	Standard depth
Hinged glass doors (consult factory)	

Consult factory for other model configurations, options and accessories.

* Adding a Riser Base increases overall height 2"

Continental[®]
Refrigerator

Toll-Free: 800-523-7138
Phone: 215-244-1400
Fax: 215-244-9579

539 Dunksferry Road
Bensalem, PA 19020
www.continentalrefrigerator.com

Project Name:

Model Specified:

Location:

Item No:

Quantity:

AIA #:

SIS #:

Standard Model Features

REFRIGERATION SYSTEM

Performance rated front breathing refrigeration system

Natural, environmentally safe,
high efficiency R-290 refrigerant¹

Automatic, hot gas condensate evaporator

Extra large, balanced evaporator coil

CABINET ARCHITECTURE

High density, non-CFC polyurethane
foamed-in-place insulation

Front, rear and side venting louvered grills

Magnetic snap in Santoprene™ door gaskets

Cylinder keyed security lock in each door

Stainless steel reinforced threshold

MODEL FEATURES

Low profile cabinet design

Electronic controller with digital display & hi-low alarm

LED interior lighting

Off-cycle defrost

Easily accessible and serviceable slide-out condensing unit

¹ R-290 refrigerant meets all federal and state regulatory requirements.

APPROVAL:

Model Specifications

DIMENSIONAL DATA

Net Capacity (cubic feet)	22 (623 cu l)
Width, Overall (inches)	79 (2007 mm)
Depth, Overall (inches) (including handles)	27 3/8 (695 mm)
Depth, Body Only (inches) (less doors)	25 (635 mm)
Height, Overall (inches)	34 3/4 (883 mm)
Capacity: # Barrel Kegs	3
Capacity: # Straight Wall Kegs	3
Capacity : # 1/6 Size Kegs	12
Number of Doors	6
Number of Shelves	6

REFRIGERANT DATA

Condensing Unit Size (H.P.)	1/4+
Capacity (BTU per hour)*	2500

ELECTRICAL DATA

Voltage (International)	115/60/1 (220/50/1)
Feed Wires (including ground)	3
Total Amps (International)	5.8 (4.9)
10 ft. Cord/Plug [attached] (International)	Yes (No)

SHIPPING DATA

Weight (pounds)	455 (206 kg)
Height - Crated (inches)	46 (1168 mm)
Width - Crated (inches)	88 (2235 mm)
Depth - Crated (inches)	42 (1067 mm)

* Rating @ +25°F evaporator, 90°F ambient
Figures in parentheses reflect metric equivalents rounded to the nearest whole unit.



Equipped with one NEMA-5-15P Plug
(varies by country)

Model Plan Views

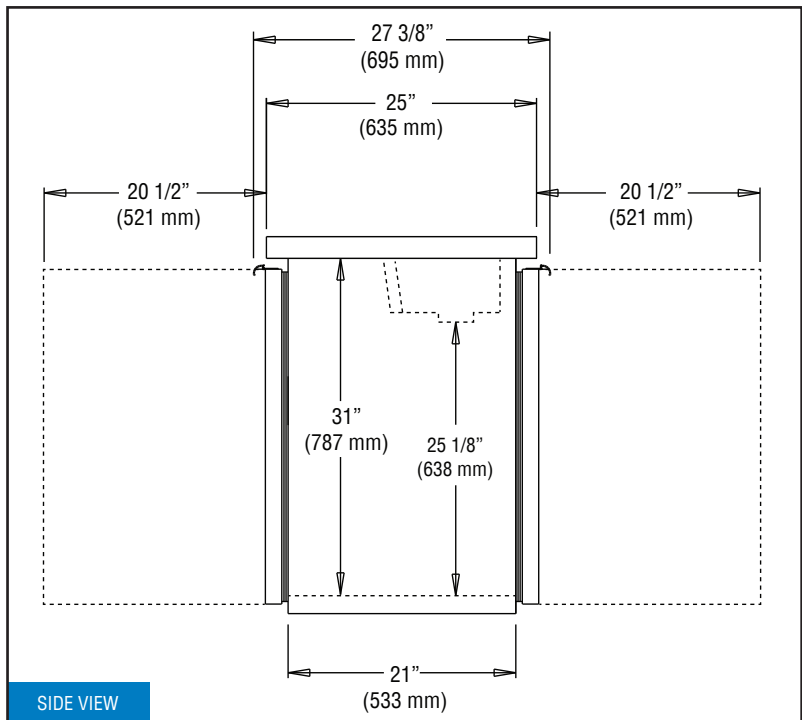
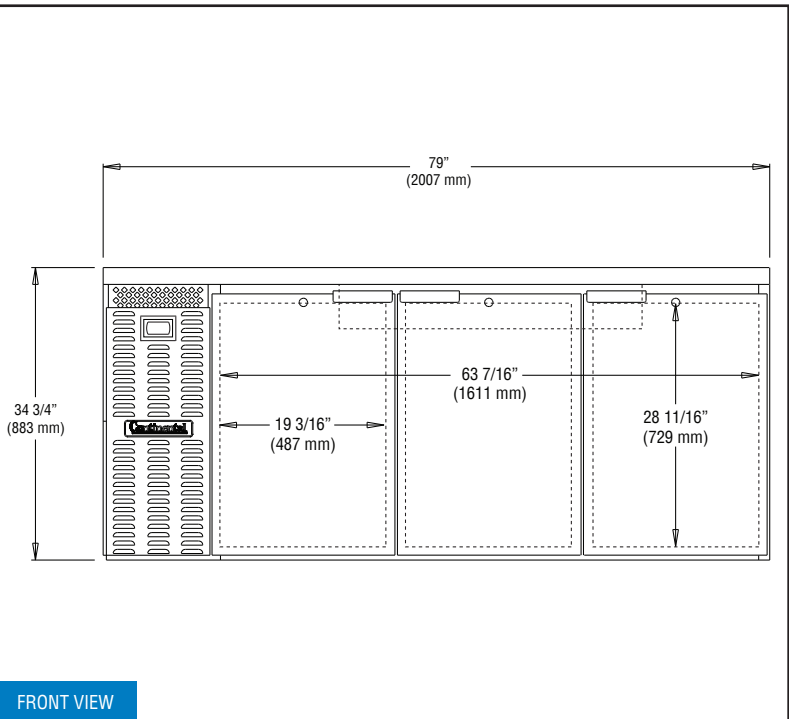

IMPORTANT NOTE: Models are completely front breathing and take in and exhaust air through the front grill. For proper operation, the area in front and back of the cabinet **must** not be obstructed in any way. A clearance of 3" on the sides is recommended.

Continental
Refrigerator

Toll-Free: 800-523-7138
Phone: 215-244-1400
Fax: 215-244-9579

539 Dunkserry Road
Bensalem, PA 19020
www.continentalrefrigerator.com

Due to our continued efforts in developing innovative products, specifications subject to change without notice.

