

Data sheet UCBTE024C_V1

Constructive Features

- cooking vessel in stainless steel AISI 304 (bottom thickness 12 mm and wall thickness 3 mm). Vessel with electric tilting on front part
- insulated lid with double cover in stainless steel AISI 304, with ergonomic handle, balanced by means of gas springs
- self-supporting frame in stainless steel AISI 304 (thickness 30-40/10)
- outer cover in stainless steel AISI 304, fine satin finish (thickness 12-15/10)
- adjustable feet in stainless steel AISI 304 to ensure levelling, with removable cover for cleaning operations
- fast accessibility to the main functional parts (electronic card, fuses, thermostats...) only removing the frontal panels
- protection level IPX5

Functional Features General

- heating by means of armoured elements in INCOLOY-800 alloy controlled by electronic board
- temperature control by system with two probes (product/bottom)
- heating tank walls by using 3 band heaters, which can be activated from the bottom up, controlled by an electronic control panel
- automatic mixing device with three arms, PTFE scrapers, complete with vertical blade for scraping walls, entirely removable to facilitate cleaning, adjustable from the control panel according to the product to be processed
- electronic control by means of multifunctional keyboard with Touch Screen 7" and easy and clear messages
- USB connection to download HACCP data, update the software and load cooking programs
- ability to interrogate the machine using communication protocol MODBUS over RS485 serial interface
- connection for power economizer

Panel Board Functions

- ON/OFF switch
- resistive 7" touch screen
- keys to turn on/off the mixer and move basin
- selection of 5 different cooking modes, with working temperature setting
- possibility of cooking with tilted basin (up to 15°)
- cooking type and time setting
- cooking in "Manual" mode
- cooking in "Program" mode
- creating and editing multiphase cooking programs, setting for each phase: type of cooking; cooking parameters (temperature and time); mixer settings; settings for heating walls and possibility to insert text messages
- wall temperature settings (range 122-266° F) and 3 levels for heating walls
- speed setting/adjustment (clockwise and counterclockwise) rotation times and mixer pause times
- possibility to activate mixer at minimum speed during tank tilting to facilitate product pouring
- tank water load setting (hot up to 140° F/cold) with automatic liter measurements
- control for tilting and return of cooking tank from Touch Screen or keyboard
- delayed cooking setting with date, time, and programming cycle
- language settings touch Screen
- input of different units of measurement (° C/° F, Liters/gallons, etc)

Display/Signal

- display type of cooking, temperature probes used and set temperature
- heating operating visual alarm
- time to end of cycle display
- display tank out of position for cooking
- audible/visible warning of mixer program start
- signaling tap position, managing water in the tank
- signal of lid and cock position during vat tilting
- thermostat intervention safety signaling
- self-diagnostics

Safety System

- emergency button
- blocking of heating for excess of temperature with manual resettable safety thermostat



Optionals

- CADE0010 - CLEANING SHOWER FOR CBT/PR
- D150 - KIT WHEELS PR/CBT/DBR
- DAPF0010 - SET FEET FOR DBR/CBT/PR
- PAF2050 - TRI-CLOVER SANITARY FITTINGS 2"
- PAF2060 - TRI-CLOVER SANITARY FITTINGS 3"

Accessories

- CAGM092 - EXTRA GRID FOR MIXER CBT.090
- PAF0701 - STRAINER FOR CBT.090-130

Certificates



Planner

.....

.....

.....

.....

.....

.....

.....

.....

.....

.....

* REG. 0 ; + 1 5/8"

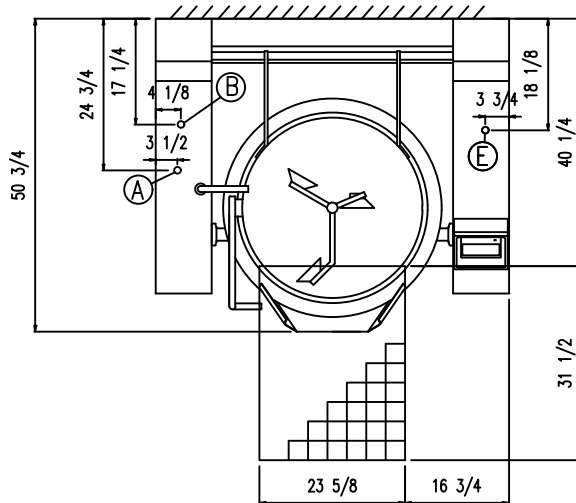
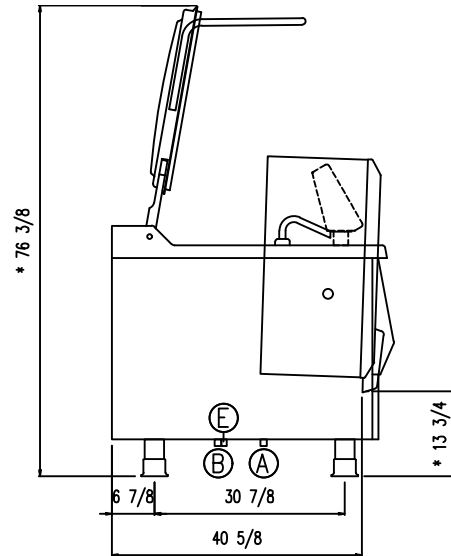
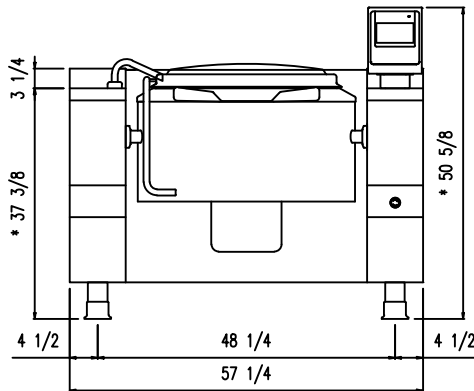

Dimensions weights and capacities

Width	57 1/4 inch	Vessel diameter	27 1/2 inch	Cooking vessel surface	589 inch ²
Depth	50 3/4 inch	Vessel height	11 3/4 inch	Weight	988 lb
Height	50 5/8 inch	Capacity	24 gal		

Mixer

Mixer torque	160 Nm	Mixer power	0.37 kW	Mixing speed	6-21 Rpm
--------------	--------	-------------	---------	--------------	----------

Water connection

Water pressure	25±50 PSI	Cold water inlet (B)	3/4"	Hot water inlet (A)	3/4"
----------------	-----------	----------------------	------	---------------------	------

Electrical connection

STD Voltage (E)	3 PHASE 220-240V ~ 60Hz	Electric power	16.20 kW	Current	39.0 A
OPT Voltage (E)	3 PHASE 208V ~ 60Hz	Electric power	15.30 kW	Current	42.5 A