

## Special Features:

- ✓ Restaurant Range
- ✓ 24" Wide Range Top
- ✓ Elevated 12" Right Side Griddle With Polished Steel Griddle Plate
- ✓ Welded Frame Structure Provides Stability
- ✓ Anti-clog standing Pilot Cover Under Each Burner Grate
- ✓ Removable Drip/Crumb Tray with Angled Handle in Front
- ✓ Insulated Stainless Steel Oven Door with Ceramic Coating
- ✓ Integrated Griddle Comes with Left and Right Splash Guard Installed
- ✓ U-Shaped Griddle Burners Provide Uniform Surface Temperature
- ✓ Kick Plate Cover at Bottom Provides Easy Access for Servicing
- ✓ Top Burner Grates are Removable

## Main Description:

The Empura EGR36-G12\_NAT is a 36" wide gas range with (4) 12" x 12" 30,000 BTU top burners, an elevated griddle with a 11 3/4" wide x 23 3/4" deep x 3/4" thick cook top, and (1) standard oven. The gas range & griddle combo includes a 24 1/2" high stainless steel backriser with a stainless-steel shelf and a 4" front ledge. This model features a welded frame construction for stability and stands on sturdy 6" adjustable stainless steel legs.

**Intended For Commercial Use Only.** Empura assumes no liability for component failure, factory defects or any other damages for units installed in non-commercial foodservice or residential applications.

## Group Description:

Empura Gas Ranges are an economical choice when you are looking to outfit, replace, or expand your commercial kitchen. Heavy duty construction, cast iron open burners, and built-in ovens make these restaurant ranges a solid, workhorse when you're making soups, stews, pastas, veggies, roasts, breads and more. You can count on an Empura Gas Range for almost any commonplace cooking task you may need accomplished.



**TECHNICAL SPECS**

**Dimensions**

|                      |         |
|----------------------|---------|
| Overall Width        | 36"     |
| Overall Depth        | 32 1/4" |
| Overall Height       | 60"     |
| Oven Interior Width  | 26 5/8" |
| Oven Interior Depth  | 25 7/8" |
| Oven Interior Height | 13 7/8" |

**Construction**

|                   |                               |
|-------------------|-------------------------------|
| Control Type      | Manual                        |
| Gas Inlet Size    | 3/4"                          |
| Installation Type | Freestanding                  |
| Number of Racks   | 2                             |
| Back Shelf Depth  | 10"                           |
| Front Ledge Depth | 4"                            |
| Heavy Duty Legs   | 6"/Stainless Steel/Adjustable |

**Cooking**

|                     |               |
|---------------------|---------------|
| Power Type          | Natural Gas   |
| Number of Burners   | 4             |
| Burner Style        | Grates        |
| Burner BTU/each     | 30,000 BTU    |
| Range Base Style    | Standard Oven |
| Number of Ovens     | 1             |
| Maximum Temperature | 550°F         |
| Oven BTU/each       | 30,000 BTU    |
| Total BTU           | 170,000 BTU   |

**Griddle**

|                              |                   |
|------------------------------|-------------------|
| Griddle Position             | Right             |
| Griddle Width                | 12"               |
| Cooking Surface Size (W x D) | 11 3/4" x 23 3/4" |
| Griddle Plate Thickness      | 3/4"              |
| Griddle BTU                  | 20,000 BTU        |

**UNIT VIEW**

**Front View**

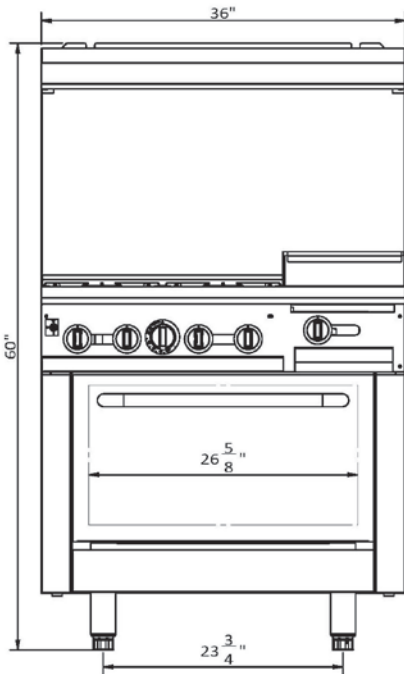

**Side View**

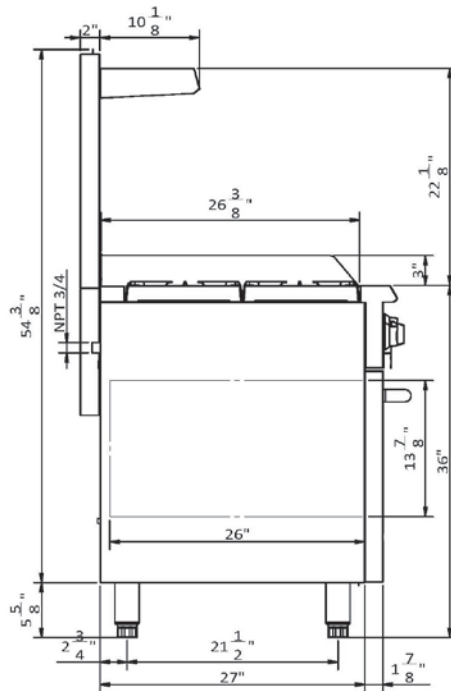

**Top View**

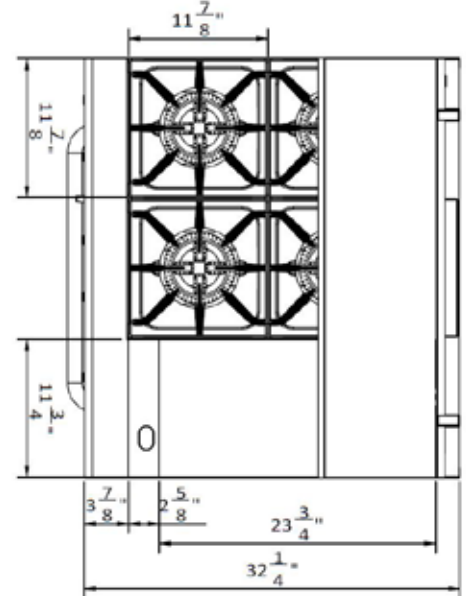

**Attention CA Residents:** This product can expose you to chemicals including lead, which are known to the State of California to cause cancer, birth defects, or other reproductive harm. For more information, go to [www.p65warnings.ca.gov](http://www.p65warnings.ca.gov).



**3/4" Gas Connection:**  
This unit comes with a 3/4" gas connection.



**Fuel Type:**  
This unit is made for use with natural gas.