

Project: _____

Item: _____

Quantity: _____

Wet Produce Cart - Heavy Duty



1408 - 1410

These carts help minimize the mess of transporting produce by retaining moisture and debris. These carts have two reinforced removable drip pans to help remove unwanted moisture and help keep work areas clean.

- Framework is constructed of 1½" x 2" x .070" wall tubing.
- Handle and uprights are constructed of 1 5/16" diameter pipe.
- Removable drip trays are constructed of .063" aluminum sheet and they are reinforced with 3/4" x 1 9/16" x .100" wall.
- Full perimeter bumper on the top shelf is standard.
- Equipped with six 5" platform type casters, four swivel and two rigid.
- Five-Year Guarantee against material defects and workmanship.
- Lifetime Guarantee against rust and corrosion.
- NSF Certified.

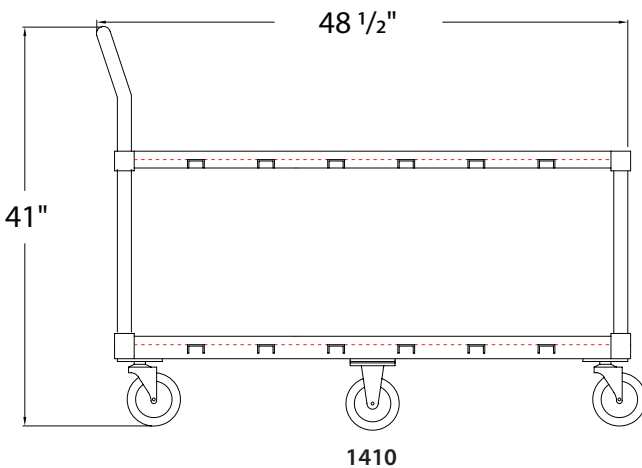

► Wet Produce Cart - Heavy Duty

Model No	Size W-H-L	Weight Capacity	Number Of Casters	Top Shelf Height	Shelf Spacing	Ship Lbs.
Carts w/ Two (2) Removable Pans						
1408	21" x 41" x 48½"	1200 lbs.	6	30"	19¼"	64
1410	29" x 41" x 50½"	1000 lbs.	6	30"	19¼"	69

Above units come equipped with a full perimeter bumper on the top shelf. Six 5" plate type casters; four swivel, two rigid.

Options: Options may not be NSF Certified. Contact the factory.

Caster Locks (2) - Add "CL" suffix to model #.



New Age Industrial Corp., Inc. || NewAgeIndustrial.com || Made in the USA

PO Box 520 • 16788 US Hwy 36 • Norton, Kansas 67654 || Phone: (800) 255-0104 • (785) 877-5121 || Fax: (877)-877-7687 • (785) 877-2616

This information is for general sales and engineering use only. New Age Industrial reserves the right to modify or make changes at any time, without notice, to materials and specifications.