

36" Electric Range with Convection Oven Base

MODEL:

R36C-M* SERIES
**M denotes Marine option*



Model R36C-ATAM shown

MARINE SHORT/BID SPECIFICATION

Range shall be a LANG Manufacturing Marine Model R36C-____ [Specify one]:

- -ATAM, with 1 ea. 24" X 24" X 1/2" thick Griddle and 2 ea. 8" diameter French Plates;
- -ATBM, with 3 ea. 12" X 24" X 3/4" thick Hot Tops;
- -ATCM, with 2 ea. 12" X 24" X 3/4" thick Hot tops and 2 ea. 8" diameter French Plates;
- -ATDM, with 36" X 24" X 1/2" thick Griddle;
- -ATDS, with 36" X 24" X 1/2" thick Griddle, plus [Submarine Spec];
- -ATEM, with 6 ea. 8" diameter French Plates
- -ATFM, with 1 ea. 12" Hot top and 4 ea. 8" diameter French plates

...a 36" wide heavy duty electric heated unit with convection oven base and 21.6-kW total power input; hatchable two piece construction with all stainless steel exterior; large capacity fully insulated oven with six sheet pan capacity, powerful blower, aluminized steel interior, heavy duty side hinged door with latch and three oven racks standard; individual oven and cook-top component controls; Sea rails and stainless steel front grab bar.

MARINE PRODUCT WARRANTY

One year, parts & labor [Labor in U.S. only]



MARINE CONSTRUCTION FEATURES

- Two piece modular construction
- Heavy duty 430 Series stainless steel exterior, with attractive No. 4 finish
- 17" high cooking compartment is aluminized steel
- Submarine Spec [ATDS] model includes stainless steel oven compartment & door liner
- 3" insulation on six sides of cooking compartment
- Right side mounted blower with 1/3 HP motor
- Incoloy sheathed oven heating elements
- Heavy duty oven door hinged-left, with positive latch
- Six position oven rack slide supports
- Three oven racks provided
- Sea rails and full width front mounted grab bar
- 2-3/4" wide full width front grease trough
- Grease drain in trough with full width & depth spillage drawers
- Griddle top configurations include one piece welded splash guard back & sides
- 6" adjustable legs w/bolt-down flange standard

PERFORMANCE FEATURES

- Multi-function 36" wide unit fits into most marine galleys
- Hatchable two-piece design allows movement through 26" X 66" watertight hatch
- Choice of 7 cook-top configurations, to include:
 - 24" wide, 1/2" thick Griddle & 2 ea. 8" diameter French plates
 - 3 ea. 12" wide Hot Top
 - 2 ea. 12" wide Hot Top & 2 ea. 8" diameter French Plates
 - 36" wide, 1/2" thick Griddle
 - 6 ea. 8" diameter French Plates
 - 1 ea. 12" wide, 1/2" thick Griddle & 4 ea. 8" diameter French plates
 - 1 ea. 12" wide Hot Top & 4 ea. 8" diameter French plates
- Large 10" X 24" X 17" high oven holds up to six 18" X 26" sheet pans
- 3 oven racks provided
- Full front grease trough, grease drain & spillage drawers speed range cleanup.
- Separate, independent controls allows precise multi-function cooking

CONTROLS [Varies by Top Configuration]

- Oven power-ON switch
- 150-450°F oven thermostat
- Damper control
- 60 minute timer with alarm
- [-ATAM] Two 450°F thermostats, one per 12" of Griddle plate & two 6-heat switches [French Plates]
- [-ATBM] Three individual 850°F thermostats [Hot Tops]
- [-ATCM] Two 850°F thermostats [Hot Tops] & two 6-heat switches [French Plates]
- [-ATDM & -ATDS] Three 450° thermostats, one per 12" of Griddle plate
- [-ATEM] Six 6-heat switches [French Plates]
- [-ATFM] One 850°F thermostat [Hot Top], Four 6-heat switches [French Plates]

36" Electric Range with Convection Oven Base *Marine Models

Model Has:	R36C-ATAM	R36C-ATBM	R36C-ATCM	R36C-ATDM R36C-ATDS	R36C-ATEM	R36C-ATFM
Oven Base:	Convection*	Convection*	Convection*	Convection*	Convection*	Convection*
Griddle:	24" wide	-	-	36" wide	-	-
French Plates:	2 each	-	2 each	-	6 each	4 each
Hot Plates:	-	3 each	2 each	-	-	1 each
Pictogram: [Unit top view]						

* 6 each, 18" X 26" sheet pan capacity

INSTALLATION REQUIREMENTS

- Single 208V or 240V, 1/3-Phase; or standard 440V/480V 3-Phase electrical connection
- Consult local and marine codes
- Installation under approved vent hood required
- [Power connection from bottom. See below]

OPTIONS

- Substitute 1" thick griddle plate
- Stainless Steel oven liner
- Grooving [requires 1" upgrade]
- MIL-SPEC Adder Package [Meets: MIL-R-43954A Grade B]
- Stainless Steel oven liner
- Oven door de-energizer switch
- 6 pan racks
- External metal serial number tag

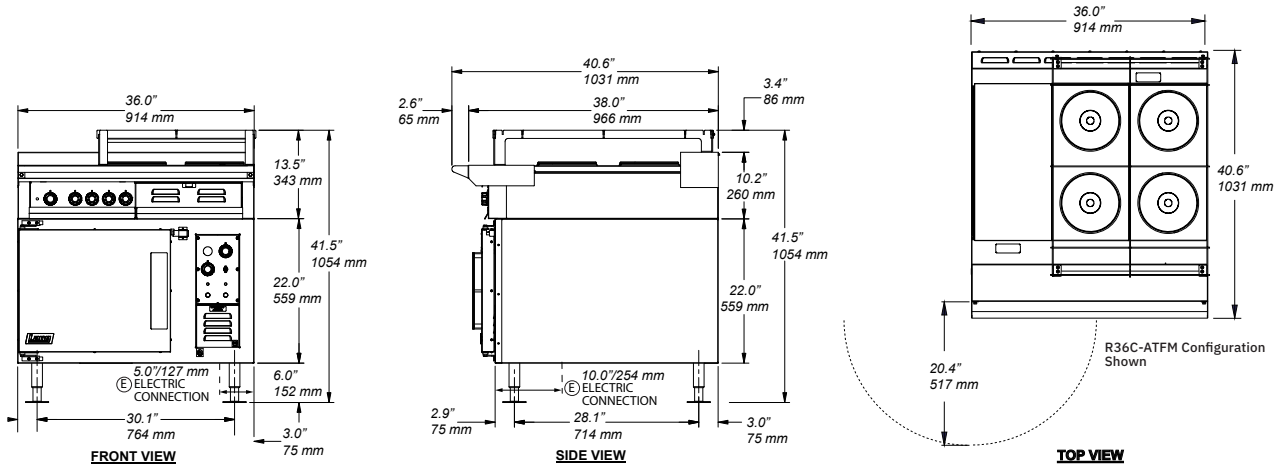

Model	Height x Width x Depth (with standard legs) 1053mm x 914mm x 1030mm	Clearance from combustible surface Sides: 4" (100mm) Back: 4" (100mm)	Weight		Freight Class 85
			Actual 425-520** lbs. 193-236** kg	Shipping 475-570** lbs. 216-259** kg	
R36C					

** Depending on configuration

Model	Volts AC - Hz	Total kW	Amps - Three Phase	Amps - Single Phase
R36C	208 - 60	21.6	69.2	103.8
	240 - 60	21.6	59.9	90.0
	440 - 60	18.2	25.2	N/A
	480 - 60	21.6	29.5	N/A

Due to continuous improvements, specifications subject to change without notice

