

Project:

Item Number:

Quantity:

INTERNATIONAL—MIRAGE® INDUCTION COUNTERTOP RETHERMALIZER



7470210



74110210

DESCRIPTION

Mirage® Induction Countertop Rethermalizers use innovative technology to run dry (without water) to improve food quality and minimize waste, while using a fraction of the energy. They ship with an induction-ready inset and improved ergonomic cover so they are ready to use upon arrival.

PERFORMANCE CRITERIA

Mirage® Induction Countertop Rethermalizers are designed to take a container of cooked food from a chilled state (below 40.0 °F [4.4 °C]) through the HACCP “danger zone” of 165 °F [73.9 °C]) in less than 90 minutes. The performance standard is measured using the NSF mixture chilled to 35 °F (1.7 °C). The electric unit will raise the temperature of this product above 165 °F (73.9 °C) in less than 90 minutes. The temperature will be maintained above 150 °F (65.6 °C) when the food product and pan or inset are used with a standard pan or inset cover, and the food product is stirred regularly.

AGENCY LISTING



CLEARANCE & REQUIREMENTS

- Install unit adjacent to non-combustibles in a flat location.
- Use only Vollrath induction-ready insets; failure to do so could cause damage and void the warranty.
- All models require unrestricted air intake and exhaust for proper operation.
- Ensure unit is level to avoid damage during operation.
- Ambient temperatures must be at or below 110 °F (43 °C) and are measured while all kitchen appliances are in operation.
- Minimum 4" (10.2cm) clearance is required at the rear and 1" (2.5 cm) at the bottom.
- To avoid damage, plug the unit into a properly grounded electrical supply that matches the nameplate rating.

Due to continued product improvement, please consult vollrathfoodservice.com for current product specifications.

ITEMS

6.6 Liter	10.4 Liter	Description	
7470210	74110210	Silver, Schuko	Include 1 Inset and 1 Lid
7470240	74110240	Red, Schuko	
7470310	74110310	Silver, UK	
7470340	74110340	Red, UK	
7470410	74110410	Silver, China	
7470440	74110440	Red, China	
7470510	74110510	Silver, Australia	
7470540	74110540	Red, Australia	
Accessories		Description	
47493		7 qt. Cover	
47494		11 qt. Cover	
88184		7 qt. Inset	
88204		11 qt. Inset	
88184NS*		7 qt. Nonstick Induction Inset	
88204NS*		7 qt. Nonstick Induction Inset	

*Nonstick insets are made to order; call Vollrath for minimums and lead time.

FEATURES & BENEFITS

- 800-watt 3D induction coil heats food evenly and efficiently.
- Units operate without water, eliminating well refilling.
- Sensors in three locations activate the Stir Light.
- Stir Light reminds user to mix to reduce burning and waste.
- Advanced controls have highly-visibility LEDs.
- Temperature setting includes °F and °C.
- Four presets for soups and mac and cheese simplify use.
- Locking function prevents unauthorized setting changes.
- New easy-to-grip cover handles enhance user experience.
- Included cover and inset provide what is needed for use.
- Additional covers and insets for pre-filling are sold separately.

WARRANTY

All models shown come with a Vollrath® standard warranty against defects in materials and workmanship. For full warranty details, please refer to vollrathfoodservice.com.

NOTICE: Use only Vollrath induction-ready insets; failure to do so voids the warranty.

DIMENSIONS shown in inches (cm)

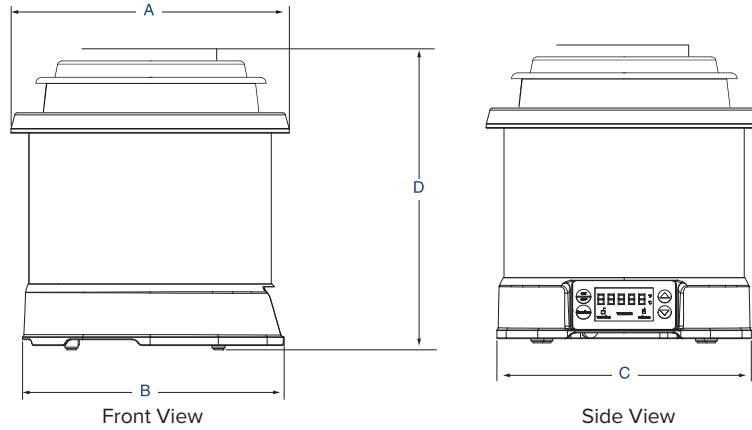

SPECIFICATIONS

Item	Color	Capacity	Volts	Watts	Amps	Hz	Dimensions				Shipping Weight & Dimensions (Including Pallet)				Plug (Included) & Receptacle
							Rim Depth (A)	Base Depth (B)	Width (C)	Height (D)	Weight lb (kg)	W	H	D	
7470210	Natural	6.6L	230	800	3.5	50/60	11 ⁷ / ₈ (30.3)	11 ³ / ₁₆ (30.2)	11 (27.9)	13 ¹ / ₂ (34.2)	14 ³ / ₄ (37.5cm)	15 ¹ / ₄ (37.5cm)	14 ³ / ₄ (37.5cm)	12.2 (5.6)	Schuko
7470240	Red														
7470310	Natural														UK
7470340	Red														
7470410	Natural														China
7470440	Red														
7470510	Natural														AU
7470540	Red														
74110210	Natural	10.4L	230	800	3.5	50/60	13 ⁷ / ₈ (35.3)	13 ³ / ₁₆ (35.2)	13 (33.0)	13 ¹ / ₂ (34.2)	14 ³ / ₄ (37.5cm)	15 ¹ / ₄ (37.5cm)	14 ³ / ₄ (37.5cm)	14.1 (6.4)	Schuko
74110240	Red														
74110310	Natural														UK
74110340	Red														
74110410	Natural														China
74110440	Red														
74110510	Natural														AU
74110540	Red														



The Vollrath Company, L.L.C.
 1236 North 18th Street
 Sheboygan, WI 53081-3201 U.S.A.
 Main Tel: 800.624.2051 or 920.457.4851
 Main Fax: 800.752.5620 or 920.459.6573
 Customer Service: 800.628.0830
 Canada Customer Service: 800.695.8560

Technical Services
 techservicereps@vollrathco.com
 Induction Products: 800.825.6036
 Countertop Warming Products: 800.354.1970
 All Other Products: 800.628.0832