

# Insulated Multi-Functional Cookers

Gas Fired, Low Lid Profile  
Insulated for Safety™  
10° Tilting, Leg Mounted  
Made in USA

# Skittle® Model SKGL

## Standard Features



**Model SKGL3-7**  
(with optional food pans)

- ◆ 304 stainless food contact zone with:
  - ◇ 304 stainless 1 ½" compression draw-off
- ◆ 304 stainless seam welded pan body with:
  - ◇ 10° tilting pan, 31" working height
  - ◇ Food pan holder under draw-off (except SKG5)
  - ◇ Insulated sides and bottom
  - ◇ Tapered access rim
  - ◇ Electronic Ignition
  - ◇ 120V, single phase (1Ø) standard
- ◆ Adjustable thermostat (175°F to 400°F)
- ◆ High limit safety thermostat
- ◆ Patented 304 stainless seam welded Capsule Lid with:
  - ◇ Variable position, actuator-assisted opening
  - ◇ Insulated sides & top
  - ◇ Adjustable steam vent
  - ◇ 304 stainless safety handle
  - ◇ "L" Lid condensate containment
- ◆ Cassette rack(s) for 12x20 food pans
- ◆ 304 stainless, seam welded component enclosure
- ◆ 304 stainless, seam welded tubular frame construction
- ◆ Single ball valve with 48" s/s flexible spray hose assembly

Legion equipment is built to comply with applicable standards for manufacturers. Approval agencies may include ASME, NSF, UL, ETL, AGA, CSA, CGA, and others. Legion reserves the right of design improvement or modification as warranted. U.S. Patent Nos. 5,553,531, 5,964,145 & Des. 371,715.

## Models and Capacities

Model	2.5" Insert Pans	Cooking Baskets	Griddle Area (in. <sup>2</sup> )	Kettle (Gals.)	Frying Oil (lbs.)	Oven Volume (ft. <sup>3</sup> )
SKGL3-5	3	2	351	7.6	35	2.8
SKGL3-7	3	3	351	10.6	35	3.2
SKGL3-9	3	3	351	13.7	35	3.6
SKGL6-5	6	4	703	15.2	70	5.6
SKGL6-7	6	6	703	21.3	70	6.4
SKGL6-9	6	6	703	27.4	70	7.3
SKGL6-11	6	6	703	33.5	70	8.2
SKGL9-5	6	6	1029	22.3	105	8.2
SKGL9-7	9	9	1029	31.2	105	9.4
SKGL9-9	9	9	1029	40.1	105	10.6
SKGL9-11	9	9	1029	49.0	105	11.8

Select draw-off valve:  1.5"  2"  3"

With:  compression  ball type fitting

See price list for other draw-off options.

Select Voltage:  120V  208V  240V

Select Gas:  Natural  Propane (LP)  Other

## Optional Features and Accessories

See price list for supplemental information regarding options

### Faucet Options:

Single ball valve mounted to frame with 48" vinyl flexible spray hose assembly

48" flexible spray hose assembly (vinyl or stainless) for use with dual or single fill faucet

Automatic water filling meter

(Call for information regarding additional faucet options)

### Prison/Security Options:

Fasteners (screws & nuts)

Nut driver tool

Draw-off nut driver tool

Screw driver tool

Lockable control cover

Draw-off protection

### Other Options:

Electric timer with buzzer

Knockdown capability for 26" x 66" opening (shipped assembled)

Gas quick disconnect 3/4"

Flexible gas hose 3/4" x 60"

### Accessories:

Perforated cooking/steaming basket (11" x 20½" x 5")

Perforated or solid 12 x 20 food pans, 2½, 4 or 6 inch deep

Draw-off drain spout

Draw-off strainer

Draw-off drain hose

#10 Can holder for draw-off

Flat bottom scoop

Fry scoop

Skittle care kit



**LEGION** Legion Industries, Inc. P.O. Office Box 728 Waynesboro, GA 30830 (800) 887-1988  
(706) 554-4411 Fax: (706) 554-2035 www.legionindustries.com sales@legionindustries.com

# Skittle® Model SKGL

Gas-Fired, Low Lid Profile  
Insulated for Safety™  
10° Tilting, Leg Mounted  
Made in USA

# Insulated Multi- Functional Cookers

DRAWING REPRESENTS MODEL SKGL9-9 WITH STANDARD 1 1/2" DRAW-OFF

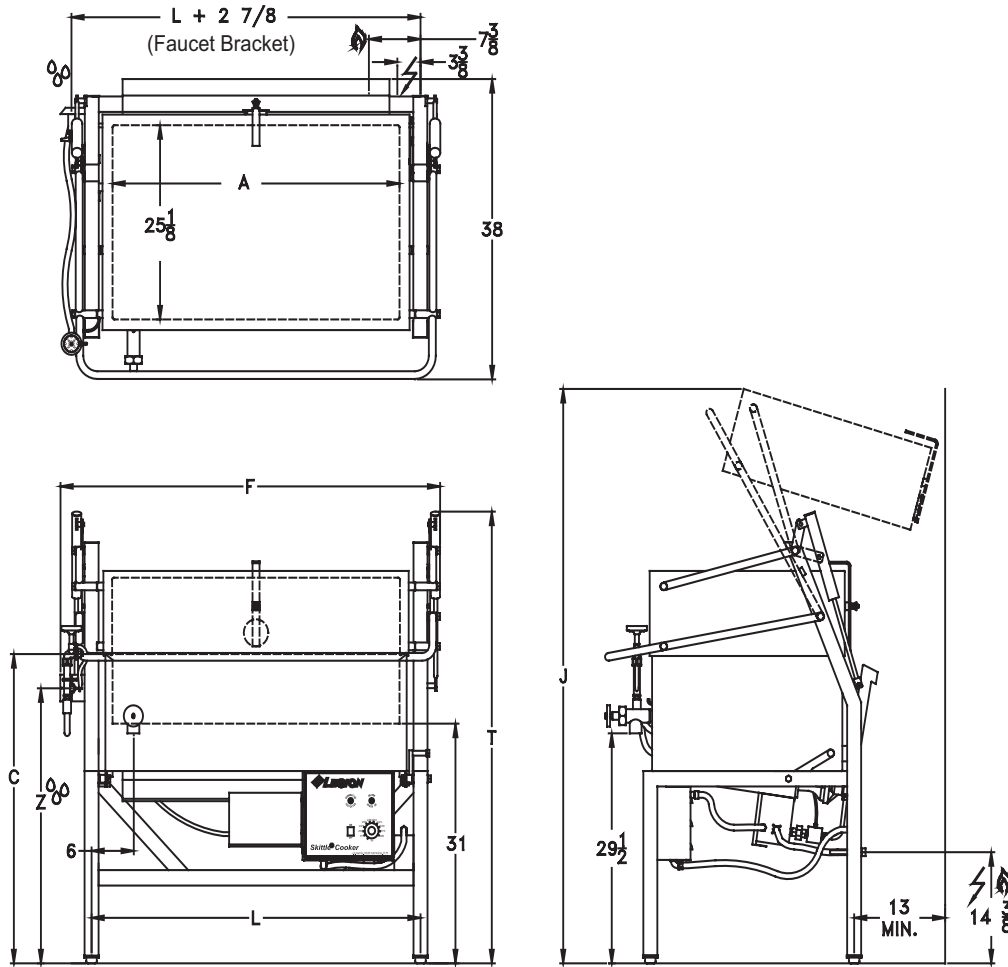

### SKITTLE® DIMENSIONS

Model*	A	F	L	Model*	A	F	L	Model*	A	F	L	Depth	C	J	T	Z
SKGL3-5	14.0	27.3	20.0	SKGL6-5	28.0	41.3	34.0	SKGL9-5	41.0	54.3	47.0	5	36.0	70.3	53.3	31.5
SKGL3-7	14.0	27.3	20.0	SKGL6-7	28.0	41.3	34.0	SKGL9-7	41.0	54.3	47.0	7	38.0	72.3	55.3	33.5
SKGL3-9	14.0	27.3	20.0	SKGL6-9	28.0	41.3	34.0	SKGL9-9	41.0	54.3	47.0	9	40.0	74.3	57.3	35.5
N/A				SKGL6-11**	28.0	41.3	34.0	SKGL9-11**	41.0	54.3	47.0	11	42.0	76.3	59.3	37.5

\*Dimensions on these drawings are applicable only when using a 1.5" diameter draw-off valve. If a 2" or 3" diameter draw-off valve is required, contact Legion for applicable dimensions.  
\*\*Vertical dimensions of 11" deep pan may be reduced by 2" to match 9" deep pan.

### SKITTLE® GAS SPECIFICATIONS

Model*	Gas Rating - Btu Input		Gas Pressure & Piping Specifications	
	Natural	Propane	Natural	Propane
SKGL3-(-)	34,000	35,000	Piping - 3/4" IPS	
SKGL6-(-)	100,000	111,000	Inlet Pressure Range, 5.0-7.0 inches w.c.	Inlet Pressure Range, 12.0-14.0 inches w.c.
SKGL9-(-)	132,000	149,000	Outlet Pressure Range, 3.5 inches w.c.	Outlet Pressure Range, 10.0 inches w.c.

U.S. PATENT NOS. 5,553,531, 5,964,145 & DES. 371,715

Revision 512



**LEGION** Legion Industries, Inc. P.O. Office Box 728 Waynesboro, GA 30830 (800) 887-1988  
(706) 554-4411 Fax: (706) 554-2035 www.legionindustries.com sales@legionindustries.com