



BEVERAGE-AIR

Project: _____	AIA#
Item: _____	
Location: _____	SIS#
Approved: _____	

PHI2 P SERIES WARMING CABINET

P SERIES TOP MOUNT WARMING CABINET

PHI2-1S Solid Double Door Warming Cabinet

**MODEL:
PHI2-1S-PT**

7 Year Parts/Labor Warranty



CABINET CONSTRUCTION

- Exterior is stainless steel front, back, side and top grille (galvanized top, bottom)
- Interior is made of corrosion resistant aluminum
- Stainless steel interior door liner
- Stainless steel breaker caps
- Full electronic control
- 22 Gauge stainless steel doors
- Adjustable electronic temp control from 80°F to 180°F
- Built-in, adjustable humidity control vent
- Safety shielded strip type heating elements
- Accepts Cart: 26" (W) x 26" (D) x 64 1/2" (H) (cart not included)
- Heavy-duty cylinder locks
- Self-closing doors with 120° hold open feature, with cam-lift hinges
- One-piece, snap-in magnetic door gasket
- Hinged front shroud
- Proximity door switch activates interior incandescent lighting
- 8' Cord and plug (see electrical data for details)

OPTIONS & ACCESSORIES

- Left or right door hinge (at time of order)
- Stainless steel interior

ELECTRICAL SYSTEM

- 20 AMP breaker required for double door units
- Strip type 750-watt heating elements, operating on 208-240/60/1, having a total of 3000 watts
- Externally mounted blower system maintains even temperature through out the food zone area



Please verify qualifying units by visiting:
www.energystar.gov/cfs

3779 Champion Blvd., Winston-Salem, NC 27105
1-888-845-9800 Fax: 1-336-245-6453
Beverage-Air.com Sales@bevair.com



BEVERAGE-AIR®

MODEL	PHI2-1S-PT
EXTERNAL DIMENSIONAL DATA	
Width Overall	68 7/8"
Depth Overall with Handle	39 7/8"
Height Overall	84 3/8"
Number of Doors	4
Depth with Door Open 90°	99"
Door Openings (in)	27 7/8" x 65 1/2"
INTERNAL DIMENSIONAL DATA	
NET Capacity (cubic ft.)	72.4
Internal Width Overall (in)	63 5/8"
Internal Depth Overall (in)	26"
Internal Height Overall (in)	66 1/4"
ELECTRICAL DATA	
Amps	11.3/13
Cabinet Voltage	208-240/60/1
Heater Watts per Section (@240V)	3000
SHIPPING DATA	
Gross Weight - Crated	675 lbs
Height - Crated	89"
Width - Crated	78"
Depth - Crated	45"

We reserve the right to change specifications and product design without notice. Such revisions do not entitle the buyer to corresponding changes, improvements, additions or replacements for previously purchased equipment. Dimensional tolerances +/- 1/4". Metric dimensions (MM).

Top Mount Roll-Thru Warming Cabinet Model: PHI2-1S-PT

Model Views

Required Clearance: Top 12"

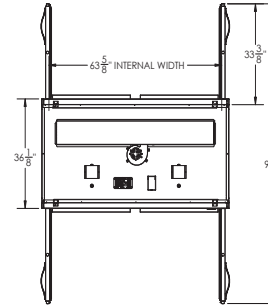

PLAN VIEW

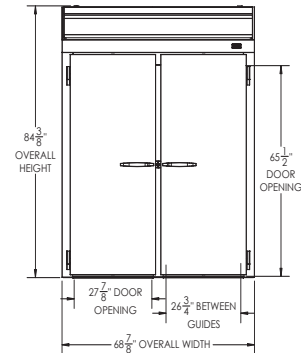

ELEVATION VIEW

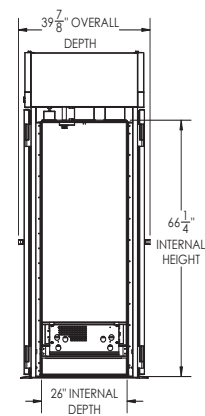

SIDE VIEW



ELECTRICAL CONNECTION



208-240/60/1
NEMA 6-20P

Unit pre-wired at factory
and include 8' long cord
and plug set.