



Profit from the Eagle Advantage®

# Specification Sheet

## Short Form Specifications

Eagle Panco® “Z” Type Nesting Rack, model \_\_\_\_\_.  
All-welded aluminum construction. “Z” shaped horizontal supports and base allow racks to take up less floor space, and “nest” inside each other. Slide spacing is 2” or 3” to accommodate (20 or 30) 18” x 26” sheet pans. Furnished with 5”-diameter casters. Shipped assembled.

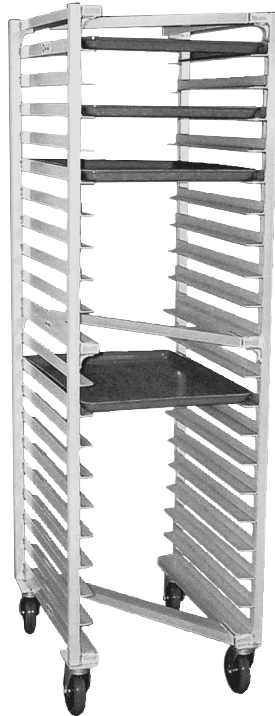

#OUR-1820-3-N  
“Z” type nesting rack

## Options / Accessories

- Casters with locking brakes
- Vertical bumpers

## EAGLE GROUP

100 Industrial Boulevard, Clayton, DE 19938-8903 USA  
 Phone: 302-653-3000 • 800-441-8440 • Fax: 302-653-2065  
[www.eaglegrp.com](http://www.eaglegrp.com)  
[www.eaglegrpnews.com](http://www.eaglegrpnews.com)  
[www.eaglemhc.com](http://www.eaglemhc.com)

For custom configuration or fabrication needs, contact our **SpecFAB® Division**.  
 Phone: 302-653-3000 • Fax: 302-653-2065 • e-mail: [quotes@eaglegrp.com](mailto:quotes@eaglegrp.com)

Item No.:	_____
Project No.:	_____
S.I.S. No.:	_____

# Panco® “Z” Type Nesting Racks

## MODELS:

- OUR-1820-3-N
- OUR-1830-2-N

## Design and Construction Features

- “Z”-shaped horizontal supports and base allow these racks to take up less square footage than standard racks when not in use; Racks “nest” inside each other.
- These racks accommodate 18” x 26” (457 x 660mm) sheet pans.
- Heavy duty all-welded aluminum construction.
- Units available with pan capacity of 20 or 30.
- 5” (127mm)-diameter heavy duty plate casters.
- 1200 lbs. (544.3 kg) maximum weight capacity per unit.
- 60 lbs. (27.2 kg) maximum weight capacity per slide.
- All models shipped assembled.



EG60.29 Rev. 12/22

Spec sheets available for viewing, printing or downloading from our online literature library at our websites

Eagle Foodservice Equipment, Eagle MHC, and SpecFAB® are divisions of Eagle Group. ©2022 by the Eagle Group



Profit from the Eagle Advantage®

Item No.: \_\_\_\_\_  
 Project No.: \_\_\_\_\_  
 S.I.S. No.: \_\_\_\_\_

# Panco® "Z" Type Nesting Racks

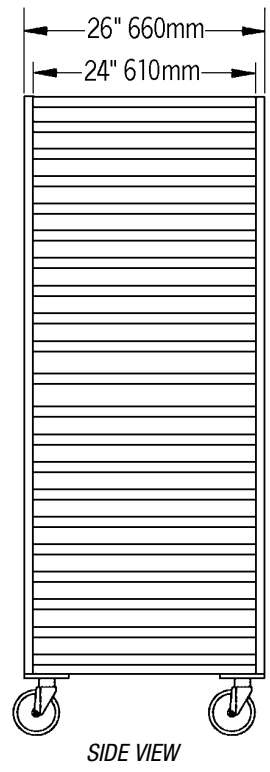
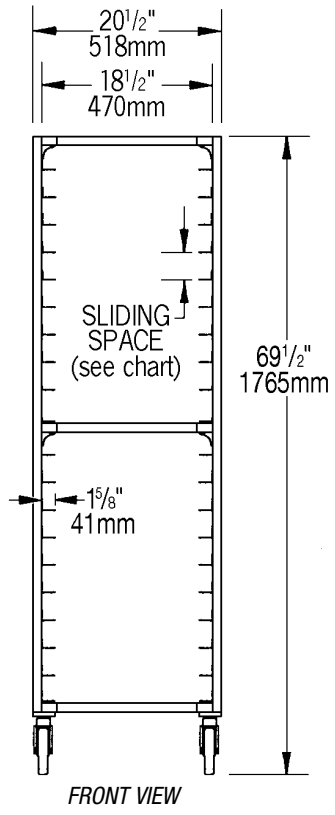
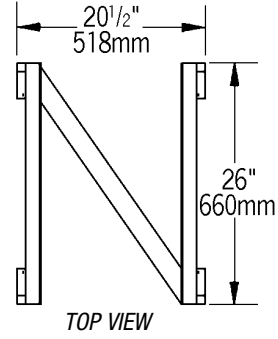

model #	overall dimensions					weight		slide spacing		pan capacity	
	width		depth		height		lbs.	kg	in.		mm
OUR-1820-3-N	20 1/2"	521	26"	550	60 1/2"	1765	69	31.3	3"	76	20
OUR-1830-2-N	20 1/2"	521	26"	550	60 1/2"	1765	83	37.7	2"	51	30

**EAGLE GROUP**  
 100 Industrial Boulevard, Clayton, DE 19938-8903 USA  
 Phone: 302-653-3000 or 800-441-8440 • Fax: 302-653-2065  
 www.eaglegrp.com • www.eaglegrpnews.com • www.eaglehmc.com

Printed in U.S.A.  
 ©2022 by Eagle Group  
 Rev. 12/22

Spec sheets available for viewing, printing or downloading from our online literature library at our websites

Although every attempt has been made to ensure the accuracy of the information provided, we cannot be held responsible for typographical or printing errors. Information and specifications are subject to change without notice. Please confirm at time of order.