

SkyLine Pro

Electric Boilerless Combi Oven 62 208V

ITEM # _____

MODEL # _____

NAME # _____

SIS # _____

AIA # _____



219931 (ECO62C2L0)

SKYLINE PRO DIGITAL
 OVEN 6 FULL SHEET PANS
 (18" X 26")ELECTRIC 208V -
 BOILERLESS

Short Form Specification

Item No. _____

- Combi oven with digital interface with guided selection, IPX5, ETL, EnergyStar, Ergocert
- BOILERLESS
 - OptiFlow: air distribution system with 5 fan speed levels
 - SkyClean: Automatic and built-in self cleaning system with integrated descale of the steam generator.
 - 2 Cooking modes: Programs, Manual
 - automatic backup mode to avoid downtime
 - USB port to download HACCP data, programs and settings. Connectivity to the cloud ready
 - Single sensor core temperature probe
 - Double-glass door with single LED lights line
 - Retractable hand-shower



APPROVAL: _____

Main Features

- Digital screen: interface with LED backlight buttons with guided selection.
- Instant steam generator: Boilerless steaming function to add and retain moisture for high quality, consistent cooking results. Automatic moistener (11 settings)
- Dry, hot convection cycle (77 °F - 575 °F/25°C - 300 °C): ideal for convection cooking.
- EcoDelta cooking: cooking with food probe maintaining preset temperature difference between the core of the food and the cooking chamber.
- Programs mode: up to 100 recipes can be stored in the oven's memory, to recreate the exact same recipe at any time. 4-step cooking programs also available.
- OptiFlow: air flow management system to achieve maximum performance in cooking evenness and temperature control thanks to the special design of the cooking chamber, the high precision variable speed fan and the venting valve.
- Reversible Fan: 5 speed fan levels from 300 to 1500 RPM with reverse rotation for optimal evenness. Fan stops in less than 5 seconds when door is opened.
- Single sensor core temperature probe included.
- Automatic cool-down and pre-heat function
- SkyClean: Automatic self cleaning system with integrated descaling of the steam boiler. 5 automatic cycles (soft, medium, strong, extra strong, rinse-only) and green functions to save energy, water, detergent and rinse aid. Also programmable with delayed start.
- 2 cleaning detergent option available: the standard, solid and liquid as an option (requires accessory)
- GreaseOut: predisposed for integrated grease drain and collection for safer operations (dedicated base as optional accessory).
- USB port: to download HACCP data, share cooking programs and configurations. USB port also allows to plug-in sous-vide probe (optional accessory).
- Connectivity: ready for real time access to connected appliances from remote and HACCP monitoring (requires optional accessory).
- Back-up mode: self-diagnosis is automatically activated if a failure occurs to avoid downtime.

Construction

- Human centered design: with 4-star certification for ergonomics and usability.
- Door handle: ergonomic wing-shaped design for hands-free door opening with elbow, to allow simple trays management (Registered Design at EPO).
- Double thermo-glazed door with open frame construction, for cool outside door panel. Swing hinged easy-release inner glass on door for easy cleaning.
- Seamless hygienic internal chamber with all rounded corners for easy cleaning.
- 304 AISI stainless steel construction throughout.
- Front access to control board for easy service.
- IPX 5 spray water protection certification for easy



cleaning.

- Supplied with 6 tray rack for full size pans, 2 2/3" pitch.

Included Accessories

- 3 of Aisi 304 stainless steel grid (18" x 26") PNC 922076

Optional Accessories

- Chicken racks, pair (2) (fits 8 chickens per rack) PNC 922036
- Single 304 stainless steel grid (12" x 20") PNC 922062
- Aisi 304 stainless steel grid (18" x 26") PNC 922076
- External side spray unit PNC 922171
- Pair of frying baskets PNC 922239
- Double-click closing catch for oven door PNC 922265
- Grid for whole chicken 1/1GN (8 per grid - 1,2kg each) PNC 922266
- USB Probe for sous-vide cooking (only for Touchline ovens) PNC 922281
- Kit universal skewer rack & (6) long skewer ovens (TANDOOR) PNC 922325
- Universal skewer pan for ovens (TANDOOR) PNC 922326
- Skewers for ovens, (6) 14" short (TANDOOR) PNC 922328
- Smoker for ovens PNC 922338
- Multipurpose hook PNC 922348
- 4 FLANGED FEET FOR 61,62,101,102 OVENS - 2" 100-130MM PNC 922351
- Grease collection tray (2 2/5") for 62 and 102 ovens PNC 922357
- GRID FOR 8 WHOLE DUCKS (1.8KG, 4LBS) - GN 1/1 PNC 922362
- HOLDER FOR DETERGENT TANK - WALL MOUNTED PNC 922386
- Slide-in rack with handle for 62, and 102 combi oven PNC 922605
- Tray rack with wheels, 62 combi oven, h=80mm (3 1/6") PNC 922611
- Open base with tray support for 62 & 102 combi oven PNC 922613
- Cupboard base with tray support for 62 & 102 combi oven PNC 922616
- Stacking kit for electric 62 combi oven placed on 62 electric combi oven or 102 combi oven PNC 922621
- Trolley for slide-in rack for 102 oven and blast chiller freezer PNC 922627
- Trolley for mobile rack for 2 stacked 62 combi ovens on riser PNC 922629
- Trolley for mobile rack for 62 on 62 or 102 combi ovens PNC 922631
- Riser on feet for 2 stacked 61 combi ovens PNC 922633
- Riser on wheels for 2 stacked 62 combi ovens, height=250mm (9 6/7in) PNC 922634
- Stainless steel drain kit for 61, 62 & 101, 102 combi oven, d=50mm (2") PNC 922636
- Plastic drain kit for 61, 62 & 101, 102 combi oven, dia=50mm (2") PNC 922637
- Trolley with 2 tanks for grease collection PNC 922638

- Grease collection kit for open base (trolley with 2 tanks, open/close device and drain) PNC 922639
- Wall support for 62 oven PNC 922644
- Dehydration tray, (12" x 20"), H=2/3" PNC 922651
- Flat dehydration tray, (12" x 20") PNC 922652
- Heat shield for 62 combi oven PNC 922665
- Heat shield for stacked ovens 62 on 62 combi ovens PNC 922666
- Heat shield for stacked ovens 62 on 102 combi ovens PNC 922667
- Fixed tray rack, 62 combi oven, h=h=85mm (3 1/3") PNC 922681
- Kit to fix oven to the wall PNC 922687
- Tray support for 62 & 102 open base PNC 922692
- 4 adjustable feet with black cover for 61,62 & 101,102 combi ovens, 150-200mm (5 9/10in - 7 9/1in) PNC 922693
- Detergent tank holder for open base PNC 922699
- Tray rack with wheels, 62 combi oven, h=65mm (2 1/2") PNC 922700
- Probe holder for liquids PNC 922714
- 4 high adjustable feet for 61,62 & 101,102 combi ovens, 230-290mm (9in - 11 2/5in) PNC 922745
- Tray for traditional static cooking, H=100mm (12" x 20") PNC 922746
- Non-stick universal pan 12" x 20" x 3/4" PNC 925000
- Non-stick universal pan 12" x 20" x 1 1/2" PNC 925001
- Non-stick universal pan 12" x 20" x 2 1/2" PNC 925002
- Frying griddle double sided (ribbed/smooth) 12" x 20" PNC 925003
- Egg fryer for 8 eggs 12"X20" PNC 925005
- Flat baking tray with 2 edges 12" x 20" PNC 925006
- Potato baker GN 1/1 for 28 potatoes (12 "X20") PNC 925008
- WOOD CHIPS OAK - 450GR PNC 930209
- WOOD CHIPS HICKORY - 450GR PNC 930210
- WOOD CHIPS MAPLE - 450GR PNC 930211
- WOOD CHIPS CHERRY - 450GR PNC 930212
- Compatibility kit for installation on previous base 62,102 PNC 930218

Front

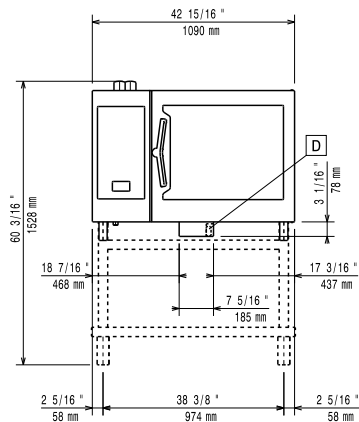

Side

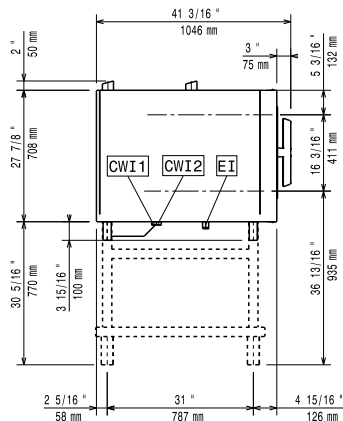

CWI1 = Cold Water inlet EI = Electrical connection

CWI2 = Cold Water Inlet 2

D = Drain

DO = Overflow drain pipe

5: Top

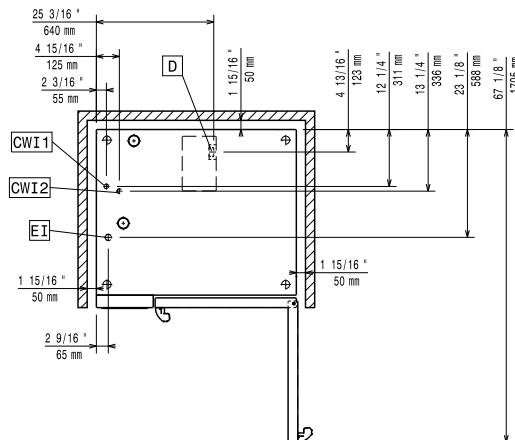

Electric

Supply voltage:

219931 (ECO62C2L0) 208 V/3 ph/60 Hz

Electrical power, default:

21.4 kW

Circuit breaker required

Current consumption:

64.9 Amps

Water:

Water inlet "FCW" connection: 3/4"

Pressure: 15-65 psi (1-4.5 bar)

Drain "D": 2" (50 mm)

Max inlet water supply

temperature: 86°F (30°C)

Chlorides: <10 ppm

Conductivity:

>285 µS/cm

Water drain outlet:

1 15/16" (50mm)

Water inlet cold 1:

3/4"

Water inlet cold 2

1/2"

Electrolux recommends the use of treated water, based on testing of specific water conditions.

Please refer to user manual for detailed water quality information.

Installation:

Clearance:

Clearance: 2 in (5 cm) rear and right hand sides.

Suggested clearance for service access:

20 in (50 cm) left hand side.

Capacity:

GN:

6 - 2/1 Gastronorm

Max load capacity:

132 lbs (60 kg)

Full-size sheet pans:

6 - 18" X 26"

Key Information:

Door hinges:

Right Side

External dimensions, Width:

42 15/16" (1090 mm)

External dimensions, Depth:

38 1/4" (971 mm)

External dimensions, Height:

31 13/16" (808 mm)

Net weight:

293 lbs (133 kg)