

Specification Sheet

Short Form Specifications

BlendPort® worktables, Budget series, model _____.
Top constructed of heavy gauge type 430 stainless steel with 1½" roll on front, 1½" rear upturn, and sides turned down 90°. Open front with 1¼" O.D. stainless steel tubular crossbracing on sides and rear. Top reinforced with welded hat channels and sound deadened. Constructed with uni-lok® patented gusset system with the gussets recessed into the hat channels to reduce lateral movement. Legs are 1½" O.D. stainless steel tubing, with stainless steel gussets and 1" stainless steel adjustable bullet feet.



worktable with upturn and tubular base
—shown with optional drawer

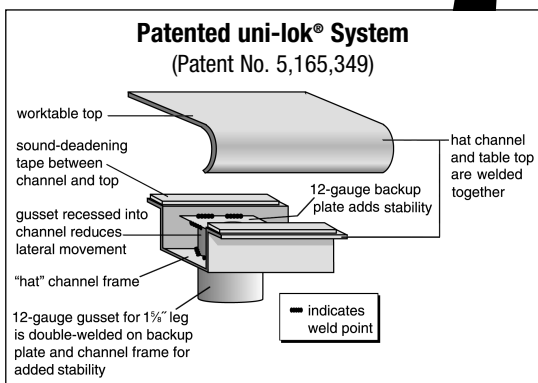

Item No.: _____
Project No.: _____
S.I.S. No.: _____

Worktables with Rear Upturn and Stainless Steel Tubular Base —Budget Series

MODELS:

- | | | |
|---|---|---|
| <input type="checkbox"/> BPT-2424STB-UT | <input type="checkbox"/> BPT-2484STB-UT | <input type="checkbox"/> BPT-3060STB-UT |
| <input type="checkbox"/> BPT-2430STB-UT | <input type="checkbox"/> BPT-2496STB-UT | <input type="checkbox"/> BPT-3072STB-UT |
| <input type="checkbox"/> BPT-2436STB-UT | <input type="checkbox"/> BPT-3024STB-UT | <input type="checkbox"/> BPT-3084STB-UT |
| <input type="checkbox"/> BPT-2448STB-UT | <input type="checkbox"/> BPT-3030STB-UT | <input type="checkbox"/> BPT-3096STB-UT |
| <input type="checkbox"/> BPT-2460STB-UT | <input type="checkbox"/> BPT-3036STB-UT | |
| <input type="checkbox"/> BPT-2472STB-UT | <input type="checkbox"/> BPT-3048STB-UT | |

Tabletop

- Top reinforced with welded-on hat channel.
- Sound-deadened between top and channels.
- 1½" (38mm) 90° rear upturn with radius at intersection.
- 1½" (41mm)-diameter 180° rolled edge on front. Ends are turned down 90° providing for flush installations when required.
- Heavy gauge type 430 polished stainless steel.

Crossbracing—1¼" (32mm)-diameter

- Heavy gauge stainless steel.
- Aluminum castings join crossbraces, legs and rear brace.

Legs—1½" (41mm)-diameter

- Units 96" to 120" (2438 to 3048mm) long come with six legs; Units 132" and 144" (3353 and 3658mm) come with eight legs.
- Patented uni-lok® gusset system (patent # 5,165,349): gussets are recessed into hat channel, reducing lateral movement.
- Heavy gauge stainless steel.
- Galvanized gussets.
- 1" (25mm) adjustable stainless steel feet.

* Optional casters available. Consult factory.

Item No.: _____
 Project No.: _____
 S.I.S. No.: _____

Worktables with Rear Upturn and Stainless Steel Tubular Base —Budget Series

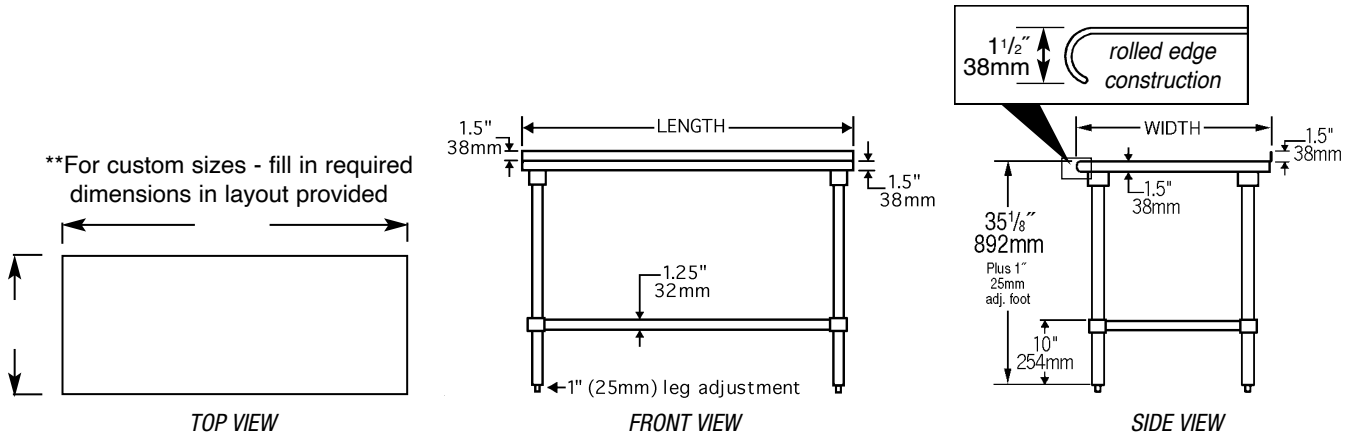

| model # | # of legs | width | | length | | weight | |
|----------------|-----------|-------|-----|--------|------|--------|------|
| | | in. | mm | in. | mm | lbs. | kg |
| BPT-2424STB-UT | 4 | 24" | 610 | 24" | 610 | 52 | 23.6 |
| BPT-2430STB-UT | 4 | 24" | 610 | 30" | 762 | 57 | 25.9 |
| BPT-2436STB-UT | 4 | 24" | 610 | 36" | 914 | 60 | 27.2 |
| BPT-2448STB-UT | 4 | 24" | 610 | 48" | 1219 | 69 | 31.3 |
| BPT-2460STB-UT | 4 | 24" | 610 | 60" | 1524 | 85 | 38.6 |
| BPT-2472STB-UT | 4 | 24" | 610 | 72" | 1829 | 92 | 41.7 |
| BPT-2484STB-UT | 4 | 24" | 610 | 84" | 2134 | 138 | 62.6 |
| BPT-2496STB-UT | 6 | 24" | 610 | 96" | 2438 | 164 | 74.4 |
| BPT-3024STB-UT | 4 | 30" | 762 | 24" | 610 | 62 | 28.1 |
| BPT-3030STB-UT | 4 | 30" | 762 | 30" | 762 | 64 | 29.0 |
| BPT-3036STB-UT | 4 | 30" | 762 | 36" | 914 | 66 | 29.9 |
| BPT-3048STB-UT | 4 | 30" | 762 | 48" | 1219 | 82 | 37.2 |
| BPT-3060STB-UT | 4 | 30" | 762 | 60" | 1524 | 89 | 40.4 |
| BPT-3072STB-UT | 4 | 30" | 762 | 72" | 1829 | 112 | 50.8 |
| BPT-3084STB-UT | 4 | 30" | 762 | 84" | 2134 | 142 | 64.4 |
| BPT-3096STB-UT | 6 | 30" | 762 | 96" | 2438 | 176 | 79.8 |

Although every attempt has been made to ensure the accuracy of the information provided, we cannot be held responsible for typographical or printing errors. Information and specifications are subject to change without notice. Please confirm at time of order.