

25 cu ft Freezers, Reach-In

- Improve the flow and function of your space by having frozen items where you need them most
- Comfortably fits 18" x 26" sheet pans (not included)
- 4 casters included (2 locking) for easy mobility
- LED lighting on glass door models



UCFZ527-SS31A



UCFZ527-SG31A

Model	Description	Voltage/Hz/Amps	Shipping Weight
UCFZ527-SS31A	25 cu ft Freezer Solid Door, Reach-In, Field Reversible Hinge	115v / 60hz / 6.2	297 lb
UCFZ527-SG31A	25 cu ft Freezer Glass Door, Reach-In, Field Reversible Hinge	115v / 60hz / 6.2	353 lb

Specifications

UCFZ527-SS31A dimensions: 82 9/32" H x 26 57/64" W x 31 1/2" D
UCFZ527-SG31A dimensions: 82 9/32" H x 26 57/64" W x 31 1/2" D
AISI 304 Stainless steel interior and exterior with lock
Autodefrost
CFC-free high-density polyurethane insulated cabinet
Environmentally friendly R290 refrigerant: 3.9 oz (0.110 kg)
Electronic digital temperature control with alarms
Factory pre-wired for dedicated outlet, 11 ft. cord and plug included NEMA 5-15P
High efficiency evaporator coil & condenser
High efficiency top-mounted compressor
NSF/ANSI Standard 7 compliant
Removable magnetic gasket for easy cleaning
Self-lubricating, sealed cast iron evaporator fan motor with high volume air flow design
Temperature range: -13°F to 14°F
Volume of 25 cu ft
1 section, includes 3 epoxy coated wire shelves

Accessories	Description	Shipping Weight
ULAQ32-0002	(1) Epoxy coated wire shelf, 20 7/8" x 25 5/8" for reach-ins	7 lb
ULA4080584	(1) Stainless steel shelf guide for all reach-ins except UCRES553 & UCFZ553, 24 3/4"	.88 lb
ULA80110300	Interior LED lighting kit for solid door reach-ins	2.2 lb



Product Specifications • 25 cu ft Freezers, Reach-In

Front (Open)

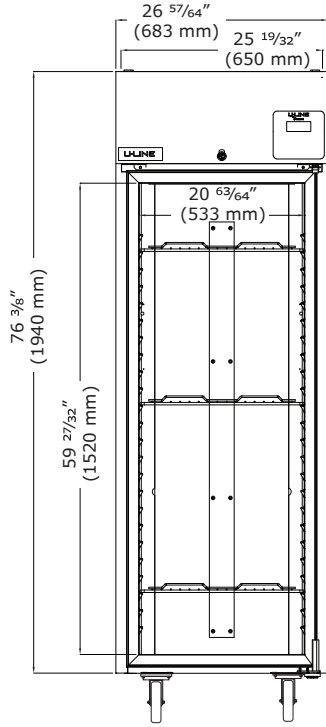

Side

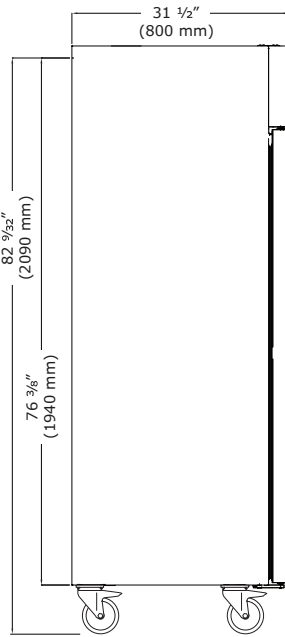

Front (Closed - Glass Door)

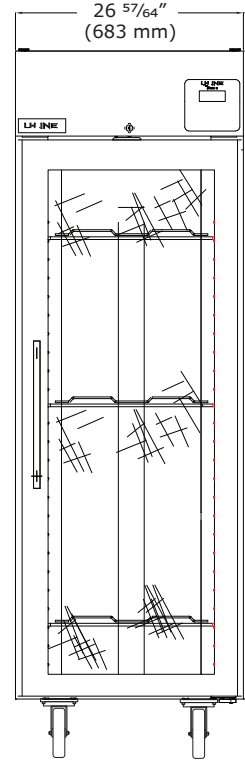

Top

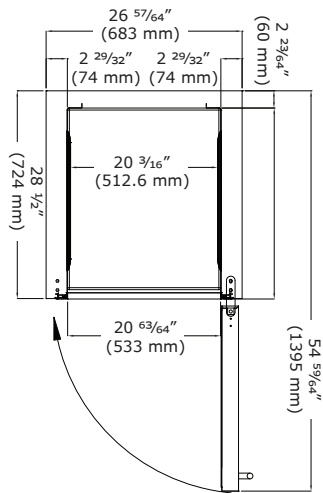

Side

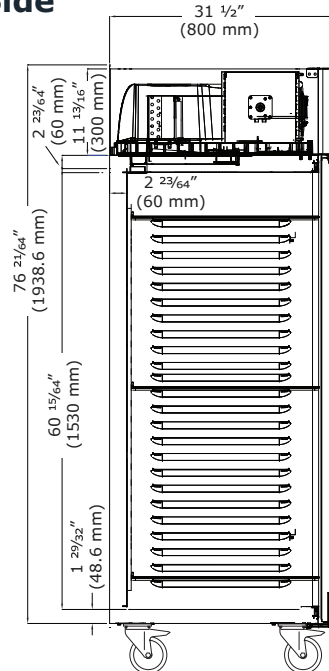

Commercial Warranty

3 Year (parts & labor) / 5 year sealed system (parts)
See complete warranty for details

