



# SPEC SHEET

## KoolMore 26 in. 1-Door Commercial Display Merchandiser Freezer 9 cu. ft. in White

SKU: MDF-1GD-9C-WH

### FEATURES

- Captivating Design: The clear glass door adds sophistication, enticing customers with an enticing view of your offerings.
- Optimal Freshness: Advanced cooling technology preserves your items at the perfect temperature, maintaining their freshness for longer.
- Safety Assured: ELT Listed for safety and sanitation, our merchandiser keeps your products secure and compliant.
- Efficient and Sustainable: Designed for energy efficiency, this merchandiser is both environmentally friendly and cost-effective.



### CLOSE UP IMAGES



# TECHNICAL SPECS

## Dimensions

Depth	26
Width	26.8
Height	55.9
Interior Depth	21.3
Interior Width	21.3
Interior Height	37.3
Shelf Width	20.9
Shelf Depth	17.7
Depth Including Handles	27.4
Depth Excluding Handles	26
Depth Less Door	24
Depth With Door Open 90 Degrees	50.7
Power Cord Length	98.5

## Capacity

Gross Cubic Feet	9.9
Net Capacity Cu. Ft.	8.3
Individual Shelf Capacity	88l bs.

## Features & Material

Door Style	Swing
Number Of Doors	1
Number Of Shelves	4
Defrost Type	Automatic
Refrigerant Type	R-290
Temperature Control Type	External Digital
Ambient Temperature Range	90 F
Temperature Range	- 7 F~0 F
Casters	4
Light Type	LED
Shelf Material Type	Epoxy Coated
Interior Material	Coated Aluminum
Exterior Material	Painted Steel

## Electric Data & Certifications

Amps	4.2
Phase	1
Plug Type	NEMA 5-15P
Voltage	115
Certifications	ETL Listed for Safety and Sanitation

# Plan View

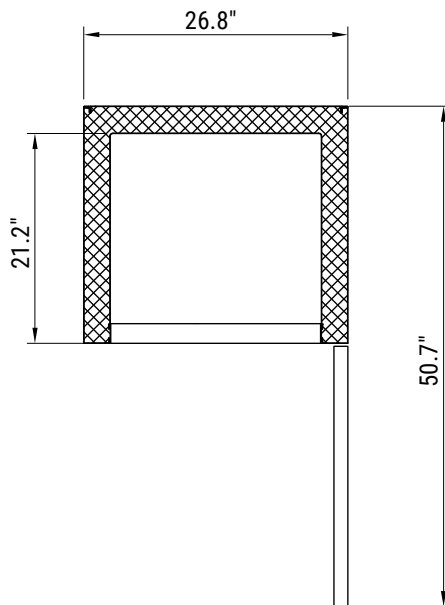
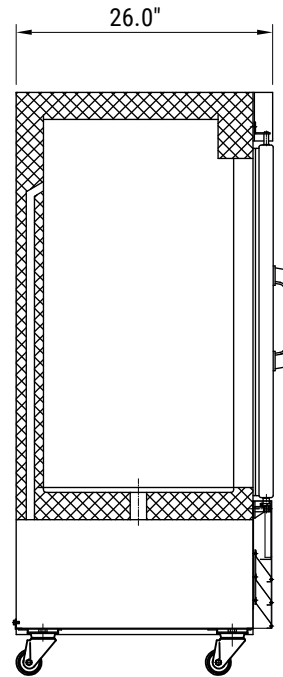
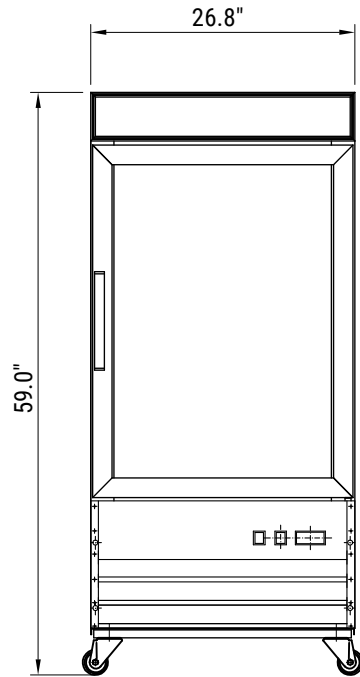

## CERTIFICATIONS



706 Eastern Parkway STE 1G, Brooklyn NY 11213  
718-576-6342  
info@koolmore.com