

# INSURICE<sup>®</sup> PF QUAD 7FC-S SYSTEM

DELIVERS PREMIUM QUALITY WATER FOR HIGH CAPACITY ICE APPLICATIONS

Insurice PF Quad 7FC-S System: EV9327-74  
7FC-S Replacement Cartridge (1 PK): EV9692-71  
EC210 Prefilter Cartridge (6 PK): EV9534-26



## APPLICATIONS

- ◆ Ice

## FEATURES • BENEFITS

- ◆ Reduces ice machine problems caused by scale buildup from dirt and dissolved minerals\*
- ◆ Sanitary cartridge replacement is simple, quick and clean; internal filter parts are never exposed to handling or contamination
- ◆ Reduces maintenance and service costs by reducing scale\* and clogging of distribution lines, evaporator plate and pump
- ◆ Proprietary Pentair<sup>®</sup> Everpure<sup>®</sup> Fibredyne™ II media inhibits the growth of bacteria on the filter media that can decrease product life
- ◆ Exclusive Pentair Everpure Fibredyne II submicron carbon block technology provides superior chlorine taste and odor reduction
- ◆ and micro-filters dirt and particles as small as 0.5 micron in size by mechanical means
- ◆ Balanced cartridge for optimum performance in varying water qualities
- ◆ Integrated beaded phosphate
- ◆ Manifold features water shut-off, flushing valve and outlet pressure gauge
- ◆ Increased capacity for extended reduction of chemical and mechanical contaminants
- ◆ 20" prefilter reduces dirt and particles
- ◆ NSF/ANSI Standard 53 certified to reduce cysts such as *Cryptosporidium* and *Giardia* by mechanical means

\*As tested by Pentair

## INSTALLATION TIPS

- ◆ Choose a mounting location suitable to support the full weight of the system when operating.
- ◆ Never use a saddle valve for connection.
- ◆ Use 3/4" water line.
- ◆ Do not connect system to water-cooled condenser.
- ◆ Install vertically with cartridges hanging down and allow 2 1/2" (6.35 cm) clearance below the cartridge for easy cartridge replacement.
- ◆ Flush cartridges by running water through system for five (5) minutes at full flow.

## OPERATION TIPS

- ◆ Replace cartridge when flow rate becomes inconveniently slow or before rated capacity is reached. It is recommended to replace cartridge at least once a year.
- ◆ Change cartridges when capacity is reached or when pressure falls below 10 psi (0.7 bar).
- ◆ Always flush the filter cartridge at time of installation and cartridge change.
- ◆ Inspect Pentair Everpure EC210 cartridge periodically to determine dirt load.
- ◆ Replace EC210 cartridge when dirt has penetrated through to the inner core of the cartridge.

## SIZING

- ◆ Service Flow Rate:  
Maximum 10.0 gpm (37.85 Lpm)
- ◆ Rated Capacity:  
100,000 Gallons (378,541 L)

# INSURICE PF QUAD 7FC-S SYSTEM

EV9327-74

Insurice PF Quad 7FC-S System: EV9327-74  
7FC-S Replacement Cartridge (1 PK): EV9692-71  
EC210 Prefilter Cartridge (6 PK): EV9534-26

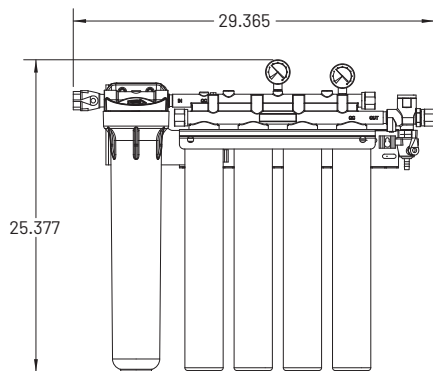

## SPECIFICATIONS

- ◆ **Service Flow Rate**  
Maximum 10.0 gpm (37.85 Lpm)
- ◆ **Rated Capacity**  
100,000 gallons (378,541 L)
- ◆ **Pressure Requirements**  
10 - 125 psi (0.7 - 8.6 bar), non-shock
- ◆ **Maximum Temperature**  
35 - 100°F (2 - 38°C)
- ◆ **Overall Dimensions**  
25.59" H X 29.36" W X 6.75" D  
(65 X 74.57 X 17.14 cm)
- ◆ **Inlet Connection** 3/4"
- ◆ **Outlet Connection** 3/4"
- ◆ **Electrical Connection**  
None required
- ◆ **Shipping Weight**  
43 lbs. (19.50 kg)
- ◆ **Operating Weight**  
55 lbs. (24.94 kg)



System Tested and Certified by NSF International against NSF/ ANSI Standards 42 and 53 for the reduction of:

STANDARD NO. 42 – AESTHETIC EFFECTS	STANDARD NO. 53 – HEALTH EFFECTS
Bacteriostatic Effects	Mechanical Filtration
Chemical Reduction Taste & Odor Chlorine	Cyst Turbidity
Mechanical Filtration Nominal Particulate Class I	

EPA Est. No. 002623-IL-002

## WARRANTY

Everpure water treatment systems by Pentair (excluding replaceable elements) are covered by a limited warranty against defects in material and workmanship for a period of five years after date of purchase. Everpure replaceable elements (filter cartridges and water treatment cartridges) are covered by a limited warranty against defects in material and workmanship for a period of one year after date of purchase. See printed warranty for details. Pentair will provide a copy of the warranty upon request.

The contaminants or other substances removed or reduced by this drinking water system are not necessarily in your water. Do not use with water that is microbiologically unsafe or of unknown quality without adequate disinfection before or after the system. Systems certified for cyst reduction may be used with disinfected water that may contain filterable cysts.

Since the conditions under which our products may be used are beyond our control, we cannot accept any liability with respect to the improper installation, application and/or use of our products.



**World Headquarters**  
1040 Muirfield Drive  
Hanover Park, IL 60133  
United States  
800.942.1153 (US Only)  
630.307.3000 Main  
cseverpure@pentair.com

**Australia**  
1-21 Monash Drive  
Dandenong South, Vic 3175  
Australia  
011.1300 576 190 Tel  
au.everpure@pentair.com

**China**  
21F Cloud 9 Plaza, NO 1118  
Shanghai, 200052  
China  
86.21.3211.4588 Tel  
china.water@pentair.com

**India**  
Boulevard, B-9/A,  
7th Floor - Tower B Sector 62  
Noida - 201301  
91.120.419.9444 Tel  
indiacustomer@pentair.com

**Europe**  
Pentair Water Belgium BVBA  
Industriepark Wolfstee,  
Toekomstlaan 30,  
B-2200 Herentals  
Belgium  
+32.(0).14.283.504 Tel  
sales@everpure-europe.com

**Japan Inc.**  
Hashimoto MN Bldg. 7F,  
3-25-1 Hashimoto, Midori-ku,  
Sagamihara-shi  
Kanagawa 252-0143  
Japan  
81.(0)42.775.3011 Tel  
info@everpure.co.jp

**Southeast Asia**  
390 Havelock Road,  
#04-01 King's Centre  
Singapore 169662  
65.6768.5800 Tel  
cseverpure@pentair.com

§ Pentair trademarks and logos are owned by Pentair plc or its affiliates. For a detailed list of where Pentair trademarks are registered, please visit [www.pentair.com/en/registrations.html](http://www.pentair.com/en/registrations.html). Third party registered and unregistered trademarks and logos are the property of their respective owners. Because we are continuously improving our products and services, Pentair reserves the right to change specifications without prior notice. Pentair is an equal opportunity employer.

EV9327-74 SE19 ©2019 Pentair Filtration Solutions, LLC. All Rights Reserved.