



CP1FB60
stainless steel doors,
and top



Intertek



Intertek

4004503
Conforms to NSF/ANSI STD 7
and UL STD 471
Certified to CSA STD C22.2 No. 120
Listed to NSF Standard 7
for open food as a storage refrigerator

Standard Features

- Self-contained
- Stainless steel interior
- Locking door(s)
- LED interior lighting
- Heated mullion to minimize condensation
- Evaporator above compressor compartment to maximize storage capacity
- Three adjustable, coated-wire shelves per door section

Project: _____	AIA# _____
Item #: _____ Qty: _____	SIS# _____
Model #: _____	

**Coolers, Pass-Thru, One Zone,
Front Serviced, Bar Profile**

CP1FB	CP1FB32, CP1FB36, CP1FB52, CP1FB60, CP1FB72, CP1FB84
--------------	---



Configurable Options

- | | |
|---|---|
| <p>Temperature:</p> <ul style="list-style-type: none"> • Beer/Food - 34°F to 40°F • White wine - 50°F to 55°F • Red wine - 60°F to 65°F <p>Refrigeration Compartment Location:</p> <ul style="list-style-type: none"> • Left or Right <p>Refrigeration Compartment Cover Finish:</p> <ul style="list-style-type: none"> • Black vinyl-clad • Stainless steel • Jeweled stainless • Laminated • Unlaminated <p>Door Style & Finish (<i>specify per door section</i>):</p> <ul style="list-style-type: none"> • Black vinyl-clad • Stainless steel • Jeweled stainless • Laminated • Unlaminated • Glass, black vinyl-clad • Glass, stainless steel • Glass, jeweled stainless • Glass, laminated <p>Door Hinge Location (<i>specify for each door</i>):</p> <ul style="list-style-type: none"> • Left or Right | <p>Door Handle:</p> <ul style="list-style-type: none"> • Signature • Pull-tab • Tube <p>Top Style:</p> <ul style="list-style-type: none"> • No finished top • Stainless top <p>Left and Right Side Finish:</p> <ul style="list-style-type: none"> • Black vinyl-clad • Stainless steel <p>LED Lighting Style:</p> <ul style="list-style-type: none"> • Bright white (7,000k) • Warm white (3,500k) • Amber (2,700k) • Blue |
|---|---|

<p>Glastender, Inc. • 5400 N Michigan Rd • Saginaw, MI • 48604-9780 989.752.4275 • 800.748.0423 • Fax 989.752.4444 www.glastender.com</p>	Approval/Notes:
<p><small>Specifications subject to change without notice. For current specifications please visit our website.</small></p>	

Coolers - Pass-Thru, One Zone, Front Serviced, Bar Profile

Specifications

		CP1FB32	CP1FB36	CP1FB52	CP1FB60	CP1FB72	CP1FB84
Dimensions	Length	32"	36"	52"	60"	72"	84"
	Number of Sections	1	1	2	2	3	3
	Door Opening	16"	20"	16"	20"	16"	20"
Electrical	Electrical Supply	120V, 1 phase, 60 Hz, dedicated 15A circuit required					
	Full Load Amps	3.5	3.5	3.5	3.5	7.0	7.0
	Plug Type	8 foot NEMA 5-15P grounded cord and plug which exits the back of refrigeration compartment*					
Refrigeration	Refrigerant	R290 - 125 grams, 4.41 oz., 0.28 pounds					
	Compressor	Reciprocating, 1/6 HP, 1300 BTUH, 0.11 Tons				Reciprocating, 1/4 HP, 2200 BTUH, 0.18 Tons	
	Heat Rejection	1430 BTUH	1430 BTUH	1430 BTUH	1430 BTUH	2867 BTUH	2867 BTUH
Operating Range		34°F (1°C) to 65°F (18°C)					
Plumbing		Automatic condensate evaporator; no drain connection required †					
Weight Bearing Capacity		Countertops and other accessories should not exceed 200 pounds per door					

Materials

- Stainless steel parts include: exterior sub-top, interior, front of cabinet, hinges, hinge and lock brackets, and optional legs
- Black vinyl-clad steel parts include: standard sides, doors and compressor cover
- Galvanized steel parts include: back and bottom
- Zinc plated CR steel parts include: leg sockets



† Building conditions outside the guidelines of ASHRAE 55 and ASHRE 62.1 may need to be plumbed to a drain.

Capacities

	CP1FB32	CP1FB36	CP1FB52	CP1FB60	CP1FB72	CP1FB84
12 oz. bottles, cases	6.6	8.8	14.6	19.1	23.1	29.9
750ml wine bottles	67	79	129	177	209	271
1/2 barrel kegs	N/A	1	N/A	2	N/A	4
1/6 barrel kegs	2	4	7	8	12	14

Coolers - Pass-Thru, One Zone, Front Serviced, Bar Profile

Drawings

PLAN VIEW

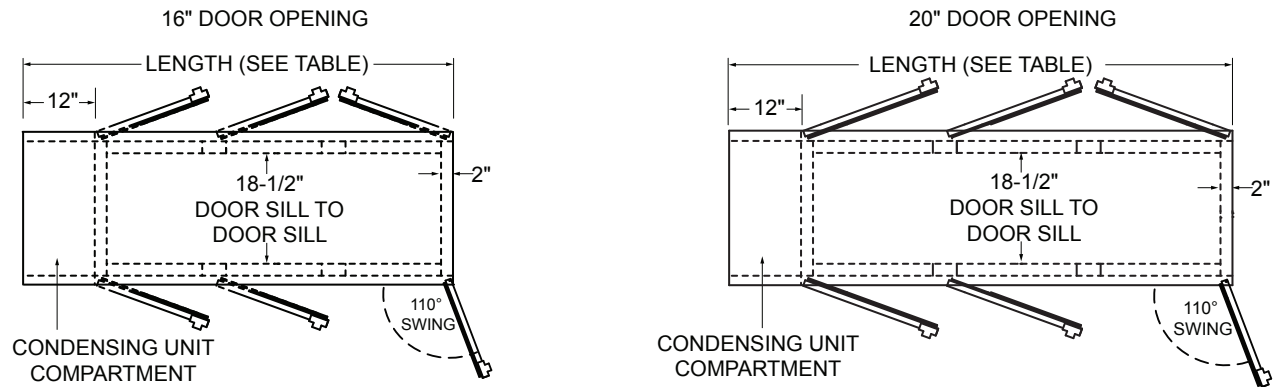

FRONT VIEW

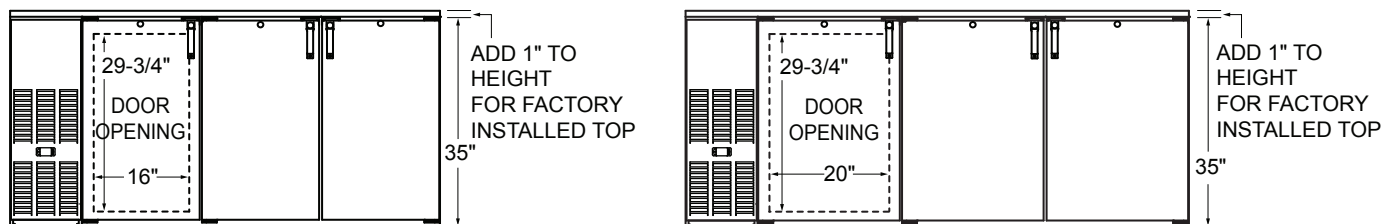

SIDE VIEW

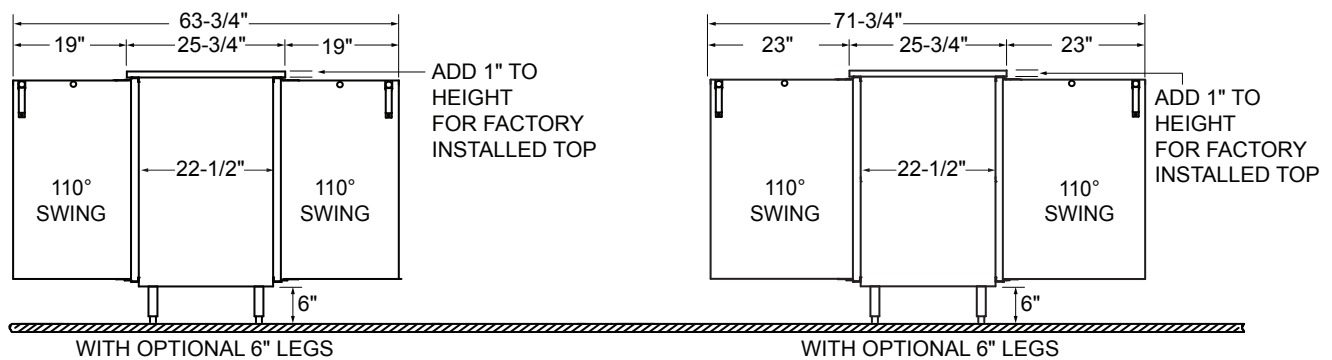

STANDARD CABINET

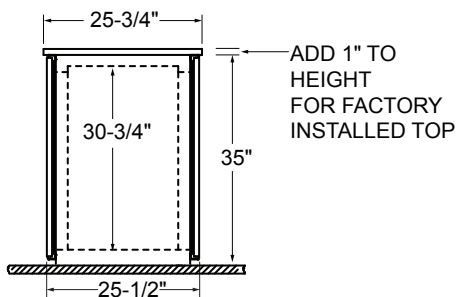

OPTIONAL LEGS AND CASTERS

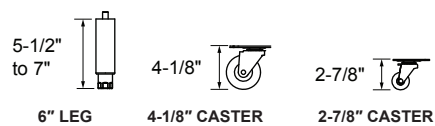

Note: Available with compressor left or right. Compressor left model shown.