

"CU-HAR" AMERICAN HERITAGE COLLECTION Maple Harvest Table - 4" Thick End Grain Top

FEATURES:

- Northern Hard Rock Maple
- End Grain Construction
- (2) Painted Slatted Shelves
- (3) Wicker Baskets
- Base Color Options Available
- Boos Block Cream With Beeswax Finish

CERTIFICATIONS:



CU-HAR60-BK

COLOR BASE OPTIONS

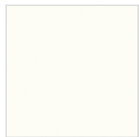

ALABASTER
(-AL)



CAVIAR BLACK
(-BK)



SLATE GRAY
(-SG)



BARN RED
(-BN)



BASIL
(-BS)



NATURAL MAPLE
(-N)



WARM CHERRY
STAIN (-CR)

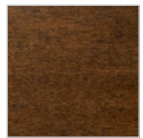

WALNUT STAIN
(-WT)



USEFUL GRAY
STAIN (-UG)

"CU-HAR" HARVEST TABLE

MODEL	TOP SIZE (L X W X H)	OVERALL HEIGHT	WT. (LBS)
CU-HAR60	60"x30"x4"	36"	280

ALL DIMENSIONS ARE TYPICAL. TOLERANCE +/- .500". JOHN BOOS & CO. RESERVES THE RIGHT TO CHANGE SPECIFICATIONS WITHOUT NOTICE.

DETAILED SPECIFICATIONS

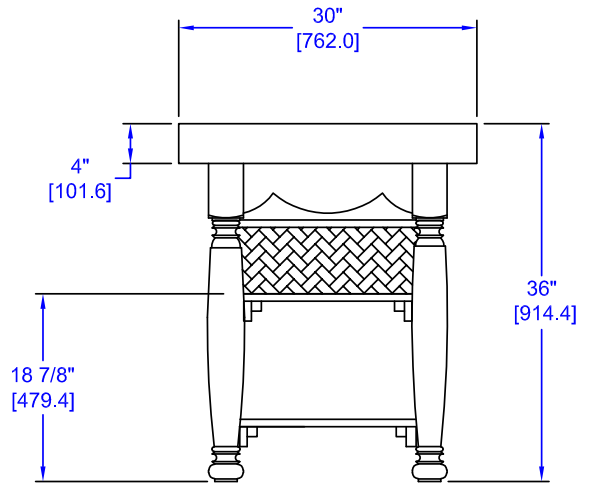
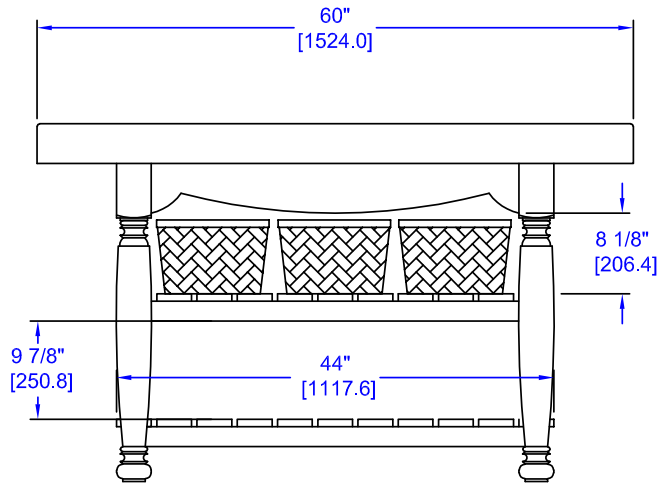
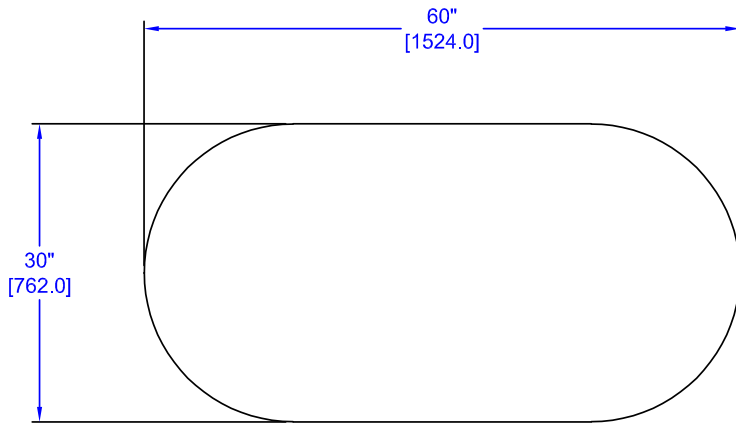

"CU-HAR" HARVEST TABLE

MODEL	TOP SIZE (L X W X H)	OVERALL HEIGHT	WT. (LBS)
CU-HAR60	60"x30"x4"	36"	280

ALL DIMENSIONS ARE TYPICAL. TOLERANCE +/- .500". JOHN BOOS & CO. RESERVES THE RIGHT TO CHANGE SPECIFICATIONS WITHOUT NOTICE.