



★ MADE in the USA ★

Warranty

See the back of this manual for the warranty.

This warranty does not apply to damages resulting from accident, misuse, abuse or alteration. No equipment may be returned without written authorization from EmberGlo (or Midco International Inc.) . Returned goods must be shipped prepaid to the factory. Warranty card must be filled in and returned to EmberGlo (or Midco) to validate warranty.

CAUTION: This manual contains sufficient information for installation of the EmberGlo Broiler in normal locations.

In the United States, installation must conform with local codes.

CODE COMPLIANCE IS THE SOLE RESPONSIBILITY OF THE INSTALLER.

CAUTION: Cooking equipment should be used in an environment protected by an automatic fire suppression system. Consult the National Fire Protection Association NFPA Code 96 or the latest edition of Standards for Installation of Equipment for Removal of Smoke and Grease-Laden Vapors From Commercial Cooking Equipment.

CAUTION: To avoid grease filter fire hazard, commercial kitchen exhaust hoods should be positioned at a minimum of 3½ feet above the broiler cooking surface, as specified by Commercial Grease Removal, Building Officials & Code Administrators International Inc. and the National Mechanical Code, 1990 Seventh Edition (or latest edition), Article 5, Section M504.0, Table M504.3.2.

WARNING: Additions, changes, conversions and service must be performed by an authorized EmberGlo representative or service agency. Use only EmberGlo specified and approved parts.



EmberGlo

EmberGlo
A Div of Midco® International Inc.
4140 West Victoria Street
Chicago, Illinois 60646
toll free 866.705.0514
tel 773.604.8700
fax 773.604.4070
web www.emberglo.com
e-mail sales@emberglo.com

Electric Char Broiler E2436

24" Wide Electric Char Broilers

Counter Top Models

Model	Voltage	Model Number
E2436	208 V Single Phase	5700301
E2436	208 V Three Phase	5700303
E2436	240 V Single Phase	5700300
E2436	240 V Three Phase	5700304
E2436	440 V Three Phase	5700305
E2436	480 V Three Phase	5700306

Floor Models

Model	Voltage	Model Number
E2436F	208 V Single Phase	5700501
E2436F	208 V Three Phase	5700503
E2436F	240 V Single Phase	5700500
E2436F	240 V Three Phase	5700504
E2436F	440 V Three Phase	5700505
E2436F	480 V Three Phase	5700506

WARNING: Improper installation, adjustment, alteration, service or maintenance can cause property damage, injury or death. Read the installation, operating and maintenance instructions thoroughly before installing or servicing this equipment.

FOR YOUR SAFETY

Do not store or use gasoline or other flammable liquids and vapors in the vicinity of this or any other appliance.

PURCHASER: Retain these instructions for future use.

INSTALLER: Inform and demonstrate to the user the correct operation and maintenance of the equipment. Inform the user of the hazards of storing flammable liquids and vapors in the vicinity of this equipment and remove such hazards.

USER: Retain this manual for future reference. If other than routine service or maintenance as described in this manual and associated literature is required, contact a qualified service agency. DO NOT ATTEMPT REPAIRS. An inadvertent service error could result in a dangerous condition.

AVOID ERROR IN PARTS SELECTION. When ordering use complete EMBERGLO Part Number and Description. Furnish Model Number, Bill of Material Number and Serial Number (if available) from the specification plate found on the product.
IMPORTANT: Availability of parts as well as specifications are subject to change without notice. Please consult factory for item availability.

SAFETY INFORMATION TERMS: The following terms are used to identify hazards, safety precaution of special notations and have standard meanings throughout this manual. They are printed in all capital letters using a bold type face as shown below, and preceded by the exclamation mark symbol. When you see the safety alert symbol and one of the safety information terms as shown below, be aware of the hazard potential.



- DANGER:** Identifies the most serious hazards which will result in severe personal injury or death.
- WARNING:** Signifies a hazard that could result in personal injury or death.
- CAUTION:** Identifies unsafe practices which would result in minor personal injury or product and property damage.

As an ISO 9001:2008 certified company, we proudly design, manufacture and assemble our products in Chicago, Illinois, USA.

Quality Designed for Proven Performance



915
8471 65
Printed in USA

E2436 - Installation and Maintenance

Installation

Wiring: All units are shipped wired for single phase current.

Ventilation: Do not install broiler closer than 5" to the back or 8" on the side walls. **LEGS SHIPPED WITH THE UNIT MUST BE INSTALLED WITH LEG CHANNELS.** Minimum leg height, with no blockage around the bottom of the broiler, must be maintained for proper ventilation. **FAILURE TO INSTALL OR REMOVAL OF THE LEGS IS A VIOLATION OF THE APPROVAL SEALS AND VOIDS THE MANUFACTURER'S WARRANTY.**

- Remove the leg channels and knobs that are packed in the broiler (located in the hopper front). The leg channels are two long pieces of U-shaped steel designed to prevent warping of the broiler frame when the broiler is moved by sliding on its legs. See Figure 1
- Prop the broiler up and line up the holes in one of the leg channels over the holes for the weld nuts on the front end of the broiler.
- Screw two of the legs provided into the weld nuts to attach the legs and hold the leg channel in place.
- Repeat procedure for the rear legs.

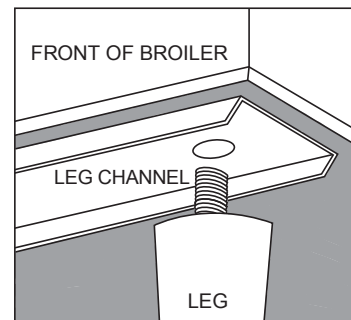

Figure 1 - Leg Placement

Turn the dial to "HI" and preheat for 20 minutes. Dial down to achieve desired cooking temperature.

Preventative Maintenance

NOTE: Always clean the unit starting at the top and working down. Be sure that the grease hopper and grease pan are in place before you proceed with any cleaning procedure in order to prevent any scapping or grease from dropping into the base and onto electrical wiring and terminal blocks.

- With normal use of the broiler, deposits build up on the top and bottom of the grate. In order to assure safe operation, these deposits must be cleaned periodically during the day from both the top and underside of the grill or grate casting.
 - a. To clear the top of the casting, scrape each groove with the tip of the scraper provided until the surfaces are clear.
 - b. To clear the underside of the casting, insert the scraper head through the slots of the grill and turn the scraper handle parallel to the grooves. Pulling upward, scrape deposits from the grill underside. Repeat for each groove.
 - c. Empty grease pan periodically to avoid messy overflow.

Daily Maintenance

- When broiling is finished for the day clean as follows:
 - a. Clean deposits from the top and bottom of the grate as explained above.
 - b. Empty the hopper, clean and reinsert hopper.
 - c. Turn unit to "HI" and leave on for approximately 20 minutes. This will char the remaining grease on the grill casting.
 - d. Turn off controls. When grill is cool, scrape the underside again and wire brush the surface to complete cleaning of the grill.
 - e. Remove and clean the side splash guards and rear trough. Wash the front and rear wells and wipe along the sides.
 - f. Wipe the casting with a dry clean cloth -- do not use water or detergent on the castings.
 - g. Empty and clean the grease pan.

E2436 Electrical Wiring Schematic - 208 & 240 Volt

Schematics

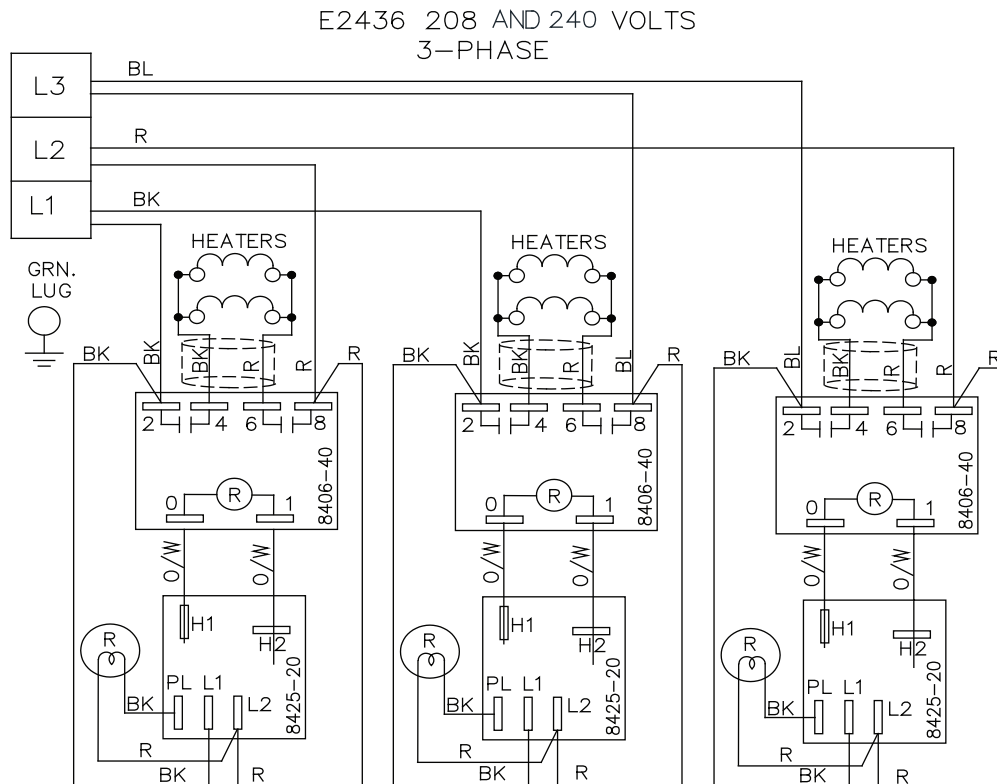
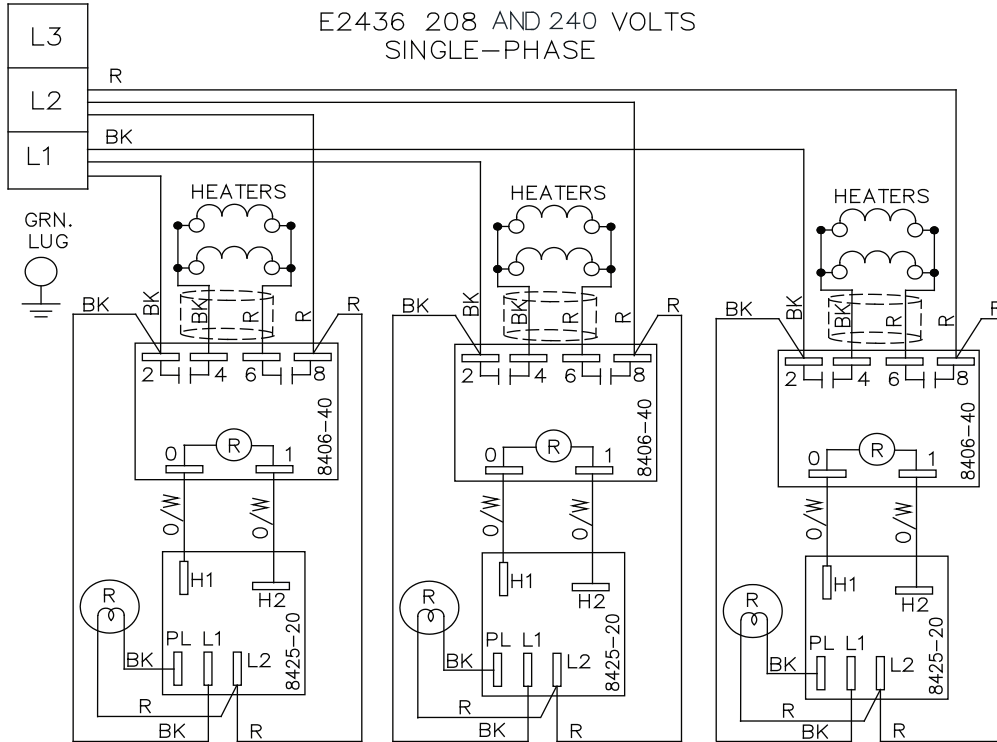

1600-33 (208 V) and 1600-34 (240 V)

Figure 2A - E2436 Schematics for 208 V and 240 V for Single Phase and 3-Phase

E2436 Electrical Wiring Schematic - 440 & 480 Volt

Schematics -
Continued

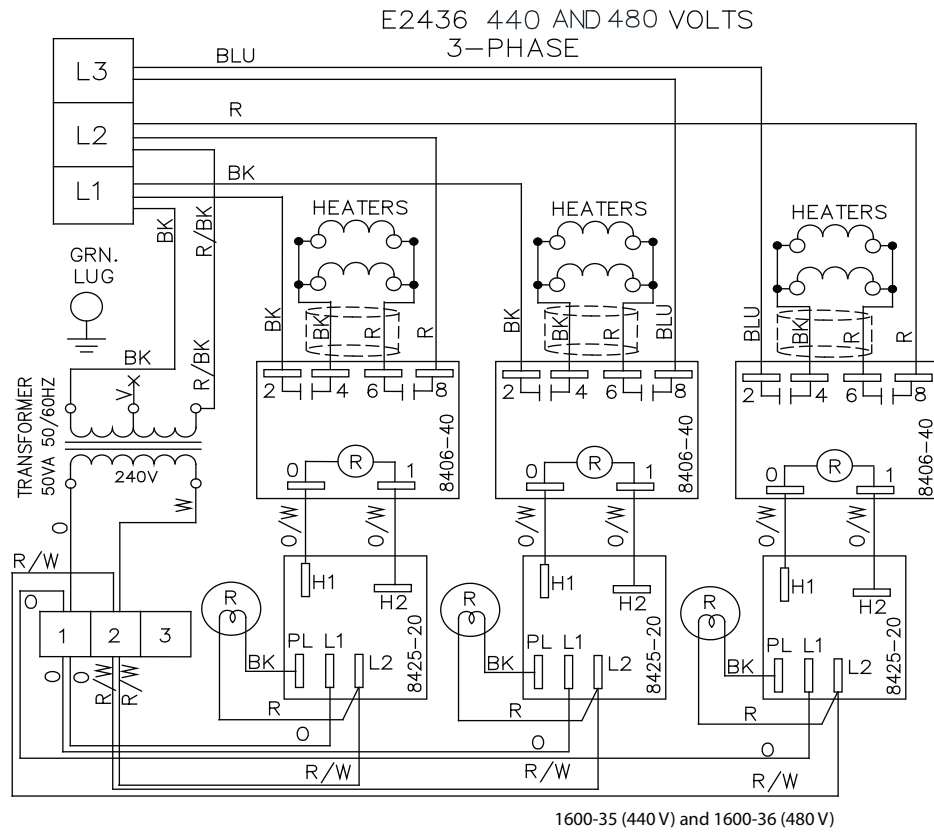

Figure 2A - E2436 Schematics for 440 V and 480 V for 3-Phase

E2436 Exploded View & Parts List

Item	Part No.	Description	Qty
1	1612-90	12" Grate w/out Element	3
2	1609-50	Heating Element 208v 1500w	6
**	1609-00	Heating Element 240v 1500w	6
**	1609-20	Heating Element 440v 1500w	6
**	1609-30	Heating Element 480v 1500w	6
3	1611-00	Element Clamp	18
4	1711-02	E36 Rear Grease Trough Channel	1
5	1610-00	E Series Right Side Splatter Guard	1
6	8406-40	Switching Relay H-D	3
7	8450-12	6 Inch Leg	4
8	1704-02	E36 Leg Channel	2
9	1604-00	Grease Pan	2
10	1605-00	Grease Pan Front	2
11	1900-03	E36 Control Panel	1
12	1615-00	Red Indicator Light Assembly	3
13	8445-15	Infinite Knob	3
14	8425-20	Infinite Switch	3
15	8408-52	3 Wire Terminal Strip	1

Item	Part No.	Description	Qty
16	4533-22	Emberglo Name Plate	1
17	1610-10	E Series Left Side Splatter Guard	1
18	1900-02	Hopper Kit	1

** Not Shown

1621-00	Grill Scraper	1
1625-04R	Relay Repair Kit	1
8447-26	Transformer	1

AVOID ERROR IN PARTS SELECTION. When ordering, use complete Emberglo part number and description. Furnish model number, bill of material number and date code or serial number from specification plate

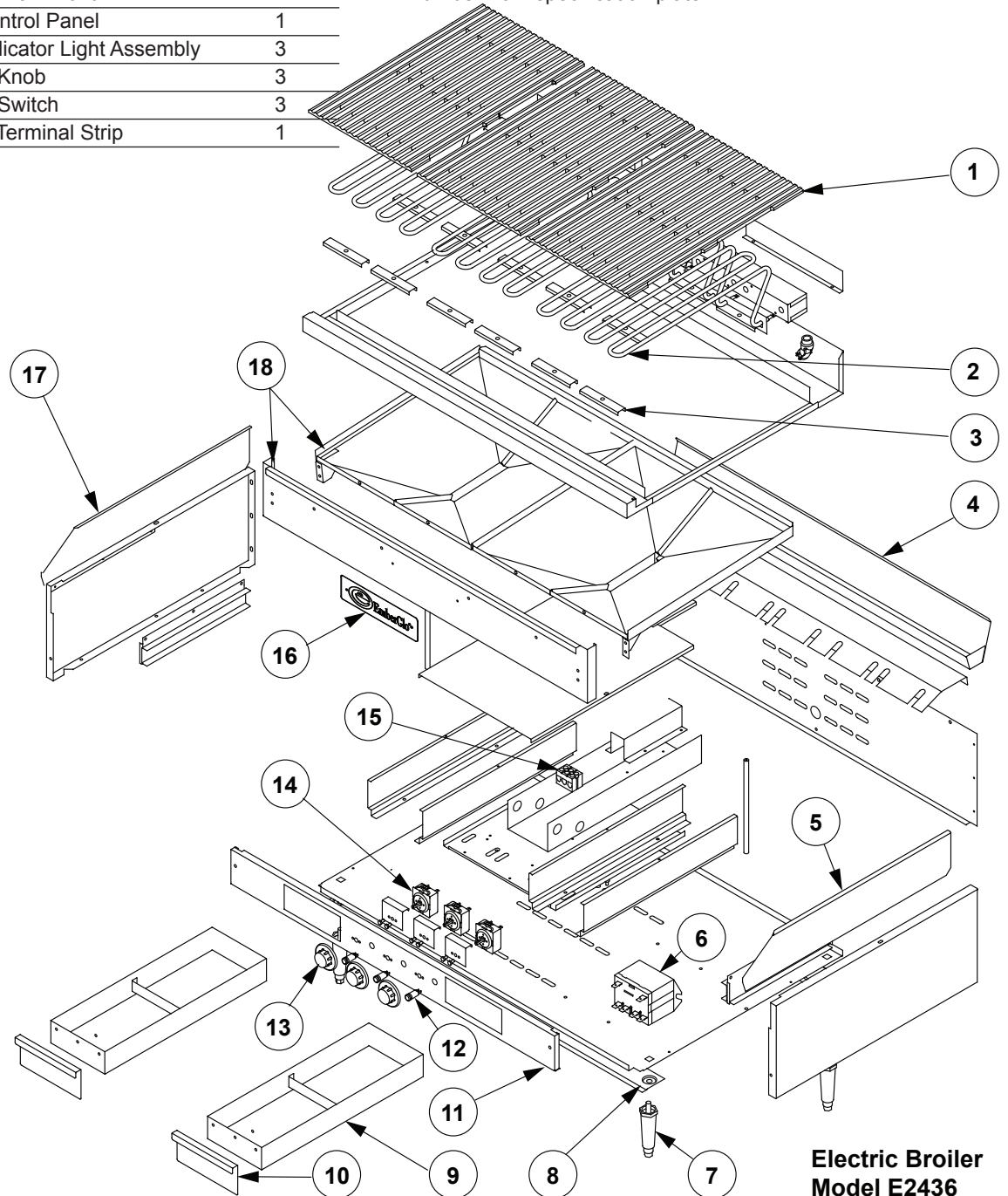

**Electric Broiler
Model E2436**

Figure 3 - Exploded View for E2436

Electric Char Broiler Cooking Guide

... Electric Char-Broiling Grilling Times ...

** Times will vary based upon load size and preference of finished product*

Beef	Thickness	Rare	Med	Well
Filet Mignon, Porterhouse	1"	8	12	16
T-Bone, Club, Rib	1-1/2"	12	16	20
Sirloin	2"	16	22	26
Strip Sirloin	3/4"	6	8	10
Hamburger, Ground Chuck, or Round	1/2"	4	6	8
Shish Kabobs	1"	--	--	18
Skirt Steak	1"	--	--	13

Fish	Thickness	Rare	Med	Well
Fillet (One side without turning)	1/2"			6
	1"			10
Fish Steaks	1"			16
	1-1/2"			20
Fish, whole & dressed	3"			5

Lamb*	Thickness	Rare	Med	Well
Center Cut Loin, Rib	1"	--	12	18
Sirloin Chops, double Rib	1-1/2"	--	17	24
English Chops	2"	--	22	27
Shoulder Chops	1"	--	12	18
Lamb Riblets	1"	--	12	18

*These times can be shortened by partial pre, or post cooking

Poultry	Thickness	Well
Broiling Chickens (ready to broil weight for 1/2 chickens)	3/4 lb	9
Chicken Breasts	1-1/2"	18
	1"	23

Shellfish	Thickness	Well
Shrimp	(Large 12-15/lb)	7
Shrimp Kabobs	(Large 12-15/lb)	10

Pork	Thickness	Rare	Med	Well
Single Chops	1/2"	--	--	18
Double Chops	1-1/2"	--	--	28
Pork Steaks	1"	--	--	15
Pork Tenderloin	1/2"	--	--	14

Vegetables	Thickness	Well
New Red Potatoes	(par boiled)	8
Zucchini sliced	1/2"	6
Corn in husk, silk removed		8 to 10
Eggplant sliced	1/2"	9 to 11

EmberGlo cooking capacities for electric char broilers were determined in compliance to UL performance standards. Hamburgers are to be 30% lean, 4" diameter x 1/2" thick. Only 2 patties are cooked per square foot of grill surface. Burgers are cooked at maximum temperature.

Production Capacity: E2412 = 60/hr.
E2424 = 120/hr.
E2436 = 180/hr.

Helpful Hints for the best performance on your Electric EmberGlo Char-Broiler:

Refer to the Electric Char Broiler Cooking Guide brochure - 8474 75E - for more helpful suggestions

1) The temperature at the grill surface, as in all cooking processes, is most important to the quality of food it produces. All units will reach proper broiling temperature with a switch setting of 5 to 5 1/2. This setting will yield between 500° and 550°. The unit will reach broiling temperature in approximately 20 minutes. Any attempt to broil for long periods of time with the controls above 6 may cause meat to burn. Higher temperatures allow for rapid cooking times and marked surfaces that some customers prefer, while low temperatures are for thick cuts of meat that must cook longer without surface excessive charring. Extreme grill temperatures should be avoided.

2) Keeping your grates clean after every broil is important. Old food isn't seasoning - it's crud. A clean grate is less likely to be sticky and will last longer.

3) At the end of the day turn unit to "HI" and leave on for approximately 20 minutes. This will char the remaining grease on the grill casting. Turn off controls. When grill is cool, scrape the underside again and wire brush the surface to complete cleaning of the grill.

4) Always clean the unit starting at the top and working down. Be sure that the grease hopper and grease pan are in place before you proceed with any cleaning procedure in order to prevent any scrapping or grease from dropping into the base and onto electrical wiring and terminal blocks. Empty grease pan periodically to avoid messy overflow.

5) Wipe the casting with a dry clean cloth -- do not use water or detergent on the castings.

Warranty

Midco® International Inc Limited Warranty Policy Exclusions Terms, Customer Requirements and Instructions

**All claims should be filed through Warranty Central.
Call factory for information (773 604 8700)**

Only Authorized Service Providers are authorized to provide Limited Warranty service on all EmberGlo®, a Division of Midco® International Inc., food equipment as described under and Midco® International Limited Warranty Policy. A list of providers can be found on our web site: www.emberglo.com

Provisions:

In lieu of an implied warranty, all repairs and replacement parts furnished under our Limited Warranty shall be f.o.b. point of distribution, but the owner must pay the necessary freight, delivery and labor costs involved when required. Any Federal, State or Local taxes are also extra. This Limited Warranty is effective for a period of one year from date of installation. EmberGlo® Char Broilers and EmberGlo® Electric Food Preparation Equipment manufactured by Midco International, sold under the EmberGlo® trademark, are guaranteed to be free from defect in material and workmanship under normal use and service for a period of 1 (one) year after the date of original installation. Midco's obligation under this Limited Warranty Policy shall be limited to repairing or replacing, at our option, any part of said equipment which Midco examination shall disclose to its satisfaction to be thus defective.

Exclusions:

This Limited Warranty Policy does not apply to damages resulting from accident, misuse, abuse or alteration, nor does it apply to limer steam generators, nor does it apply to any consequential damages. Most geographical areas require the use of distilled or demineralized water. Tap water is permissible only with ES Series Steamers. Nor does it apply to Barbriq's®, briquettes, or rods used in gas broilers. Midco's obligation will be the replacement of the product or parts removed.

Terms:

Under the terms of this Limited Warranty Policy, models considered portable (devices with cords and plug caps such as EmberGlo Steamers) must be taken or returned to the nearest service provider, transportation prepaid, where transportation collect. Non-portable units with permanent wiring will be serviced on the customer's premises. Under these terms, Midco agrees, within the terms of this Limited Warranty period, to make all repairs at no charge by the authorized service provider. Labor and mileage charges submitted by any other provider not authorized will be the responsibility of the customer.

Customer Requirements:

All charges related to repairs made one (1) year after the date of original installation, during the Limited Warranty period will be the responsibility of the customer. The product registration information is located on the product I.D. plate.

If a part is defective due to workmanship or materials and is removed from the product within the applicable warranty period and returned to Midco in accordance with the following procedure described, Midco will, at its option, either repair or replace the part.

Call the factory for instructions on returned goods.

No equipment may be returned without written authorization from MIDCO. Returned goods must be shipped prepaid to the factory.

 WARNING: Improper installation and use of this product could result in personal or property injury.



★ **MADE** in the **USA** ★

As an ISO 9001:2008 certified company, we proudly design, manufacture and assemble our products in Chicago, Illinois, USA.



EmberGlo A Division of Midco International - 4140 West Victoria Street - Chicago, Illinois 60646
toll free: 866 705 0515 - tel: 773.604.8700 - fax: 773.604.4070 - web: www.emberglo.com - e-mail: sales@emberglo.com



915
8471 65
Printed in USA