

HSM Series

Heated Shelf Merchandiser



HSM-36/2S/T(F), HSM 36/3S/T & HSM-36/5S/T
UL

Featuring exclusive Halo Heat® technology, Alto-Shaam heated shelf merchandisers provide precise top and bottom heat for the highest quality prepared food and longer hold times.

Hold a variety of grab-and-go products, including rotisserie chickens, pizza, sandwiches, and more. Drive foodservice profits with hot, ready-to-eat meals. Convenient, fresh meals are displayed in an aesthetically pleasing, customizable merchandiser.

Experience better quality food with gentle, even and precise Halo Heat® fanless technology to keep food from drying out.

Flexibility to control individual shelf temperatures allows you to hold a variety of products at the proper temperature.

Boost impulse sales with LED-lighted shelves, customized branding, backlit interchangeable graphics, pricing rails and window sides.

Simple operation and easy cleaning keeps delis and grab-and-go areas operating smoothly.

Easy-to-load shelves—pass-through option available for added convenience.

Made in the USA with a commitment to quality. Alto-Shaam is ISO 9001:2015-certified.

Standard Features

- Adjustable thermostat per shelf with a heat-on indicator light
- Latched access panel on the front of the merchandiser
- Four casters (floor standing models); four legs (countertop models)

16 HSM-36/2S/T(F):
Two (2) 32-7/8" [835mm] width shelves,
Eight (8) chicken boats with dome cover per shelf.



24 HSM-36/3S/T:
Three (3) 32-7/8" [835mm] width shelves,
Eight (8) chicken boats with dome cover per shelf.

40 HSM-36/5S/T:
Five (5) 32-7/8" [835mm] width shelves,
Eight (8) chicken boats with dome cover per shelf.



HSM-36/2S/T(F): 48 lb [22 kg] 24 lb [11 kg] per shelf

HSM-36/3S/T: 72 lb [33 kg] 24 lb [11 kg] per shelf

HSM-36/5S/T: 120 lb [54 kg] 24 lb [11 kg] per shelf



CHECK FIRST

- Merchandiser must be installed level.
- Merchandiser must not be installed in any area where it may be affected by steam, grease, dripping water, high temperatures, or any other severely adverse conditions.



Configurations (select one)

Model

- HSM-36/2S/T HSM-36/3S/T
 HSM-36/3S/T/F HSM-36/5S/T

Electrical

- 120V, 1PH (HSM-36/2S/T or HSM-36/2S/F only)
 208–240V, 1PH

Door Options

- None (reach-in models only)
 Rear slide (pass-through models only)
 Rear swing (pass-through models only)
 Front swing (reach-in and pass-through models)

Legs or Casters (floor standing)

- 4"–6" [102mm–153mm] adjustable legs [5025454]
 3" [76mm] casters (Standard)

Legs or Display Base (countertop)

- 4"–6" [102mm–153mm] adjustable legs: [Standard] [5026182]
 HSM-36/3S Display Base, with casters [5026176]
 HSM-36/3S Display Base, with legs [5026182]

Accessories (select all that apply)

Note: Unit ships without graphics unless selected

- Signage panel, POP Display
- Signage panel, shelf — Rotisserie Chicken
- Signage panel, shelf — Hot Sandwiches
- Signage panel, shelf — Barbecue Ribs
- Signage panel, shelf — Hot & Tasty
- Signage panel, shelf — Grab & Go
- Signage panel, shelf — Hot & Fresh
- Shelf insert for magnetic signage panels, HSM-36 [1027305].
Magnetic signage panels to be provided by customer.

qty



HSM Series

HSM-36/5S/T

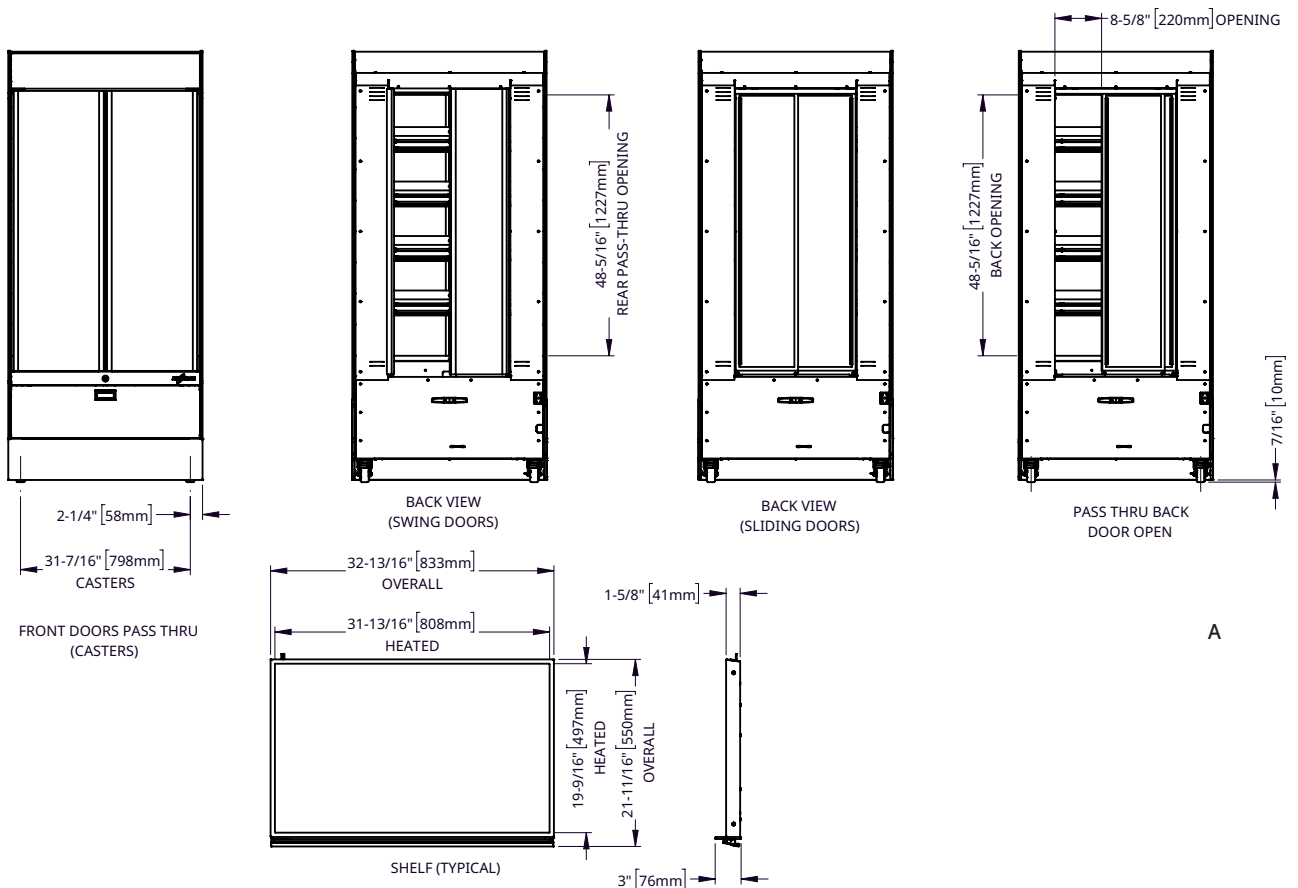
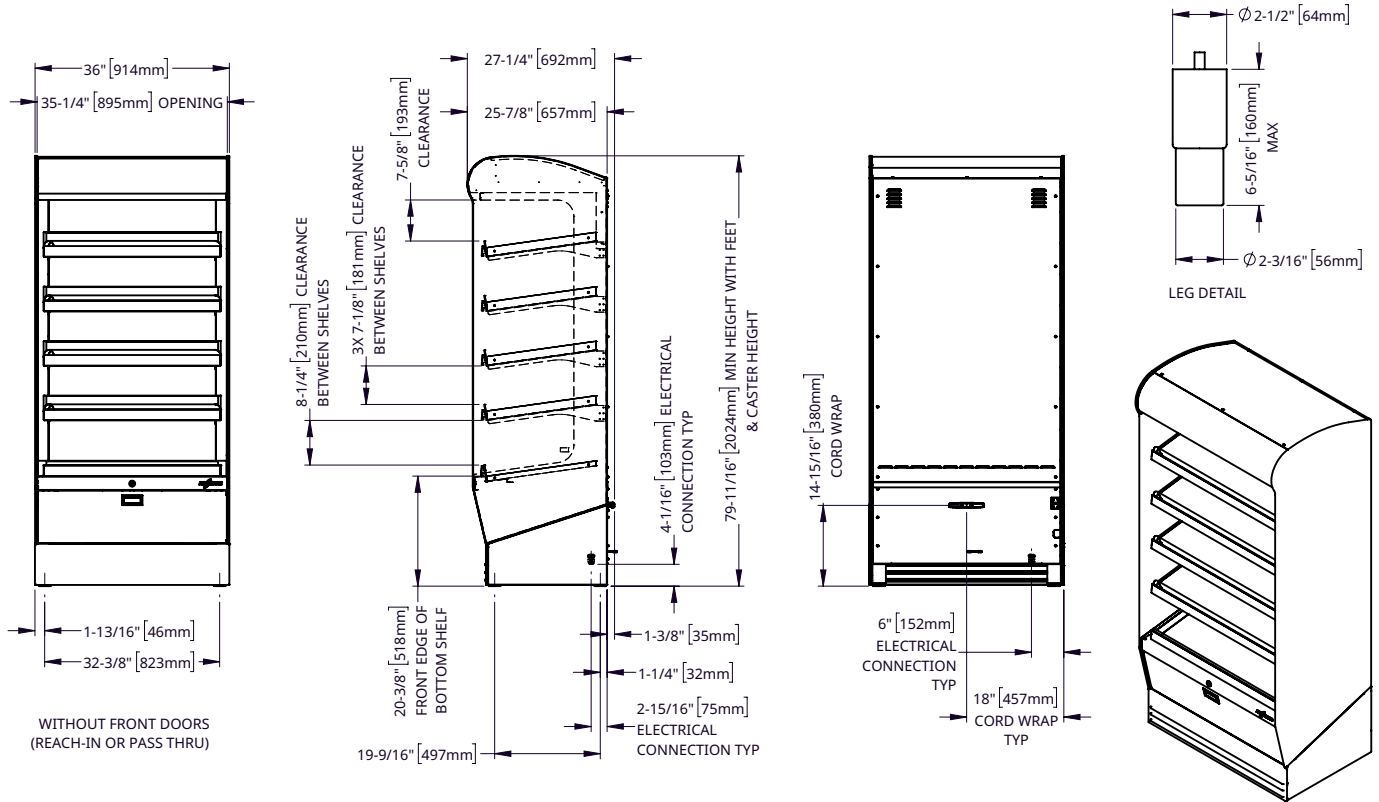

HSM Series

HSM-36/3S/T

ALTO-SHAAM

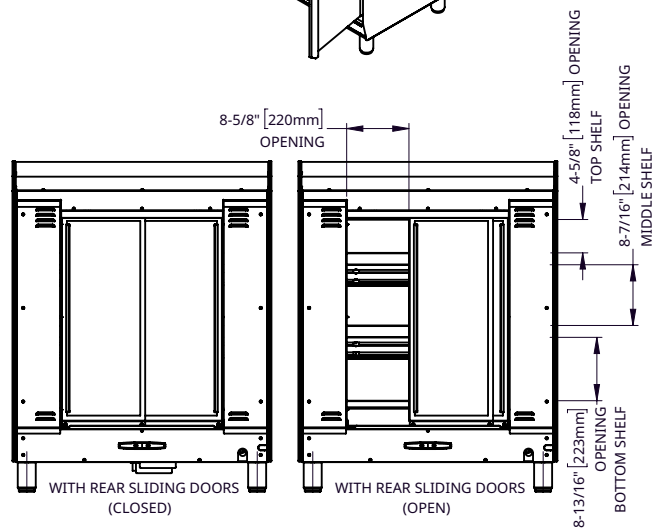
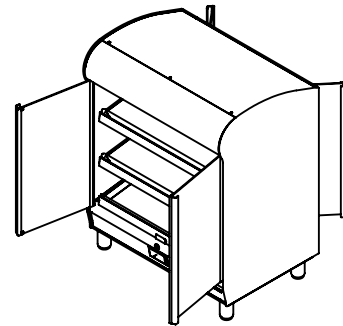
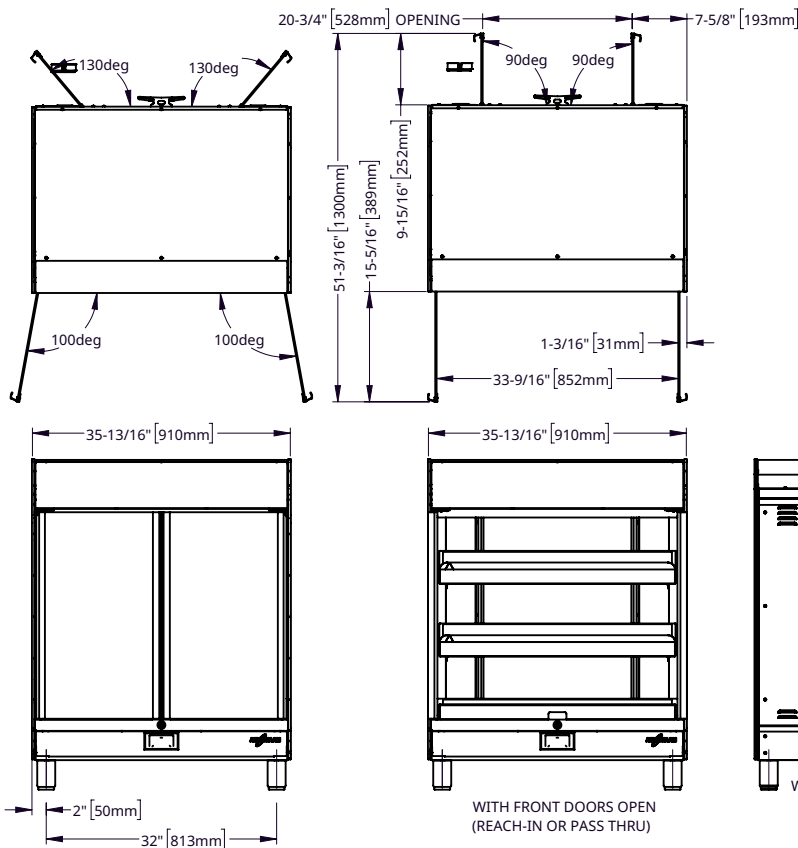
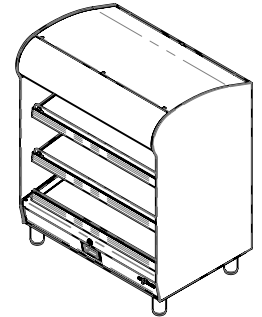
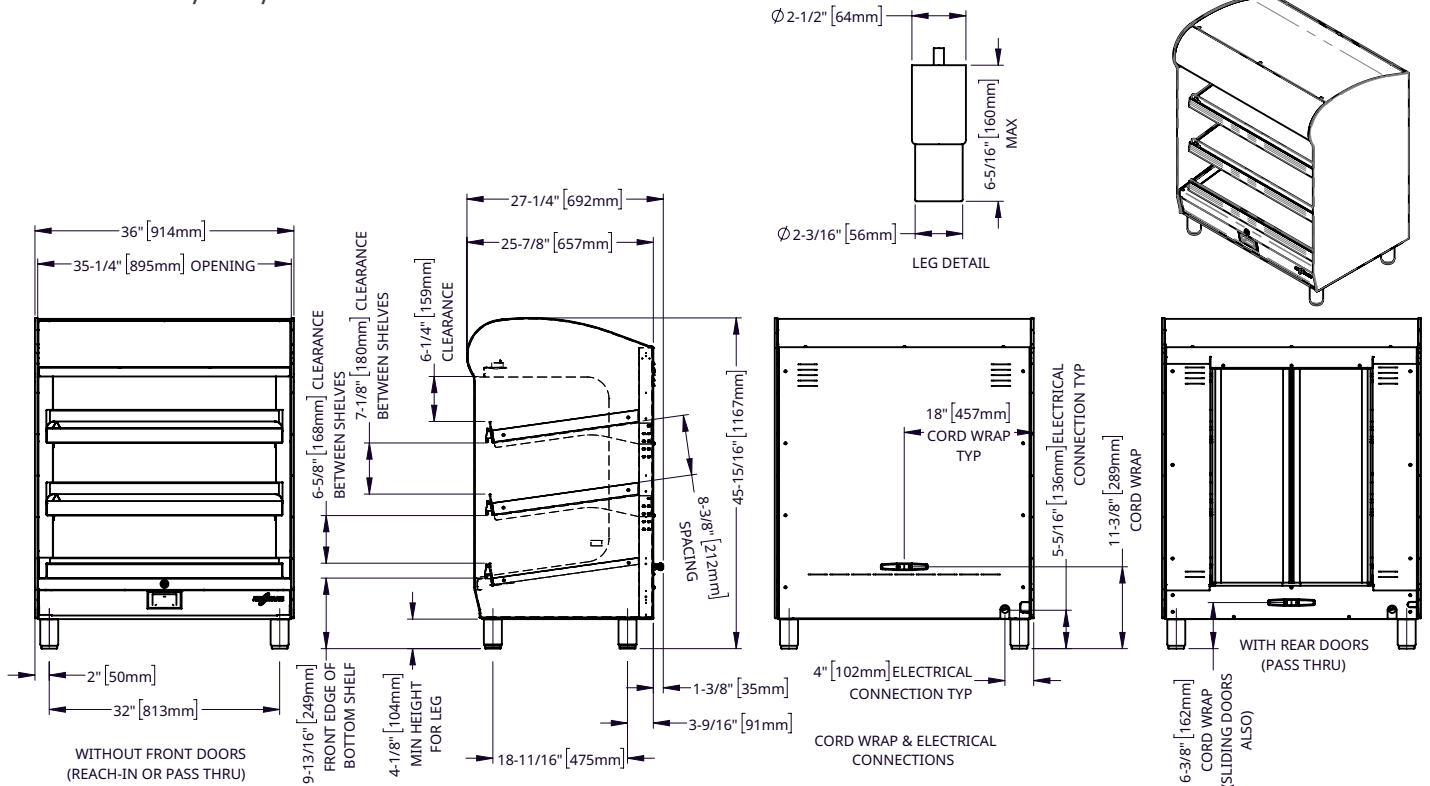

HSM Series

HSM-36/2S/T/F

ALTO-SHAAM

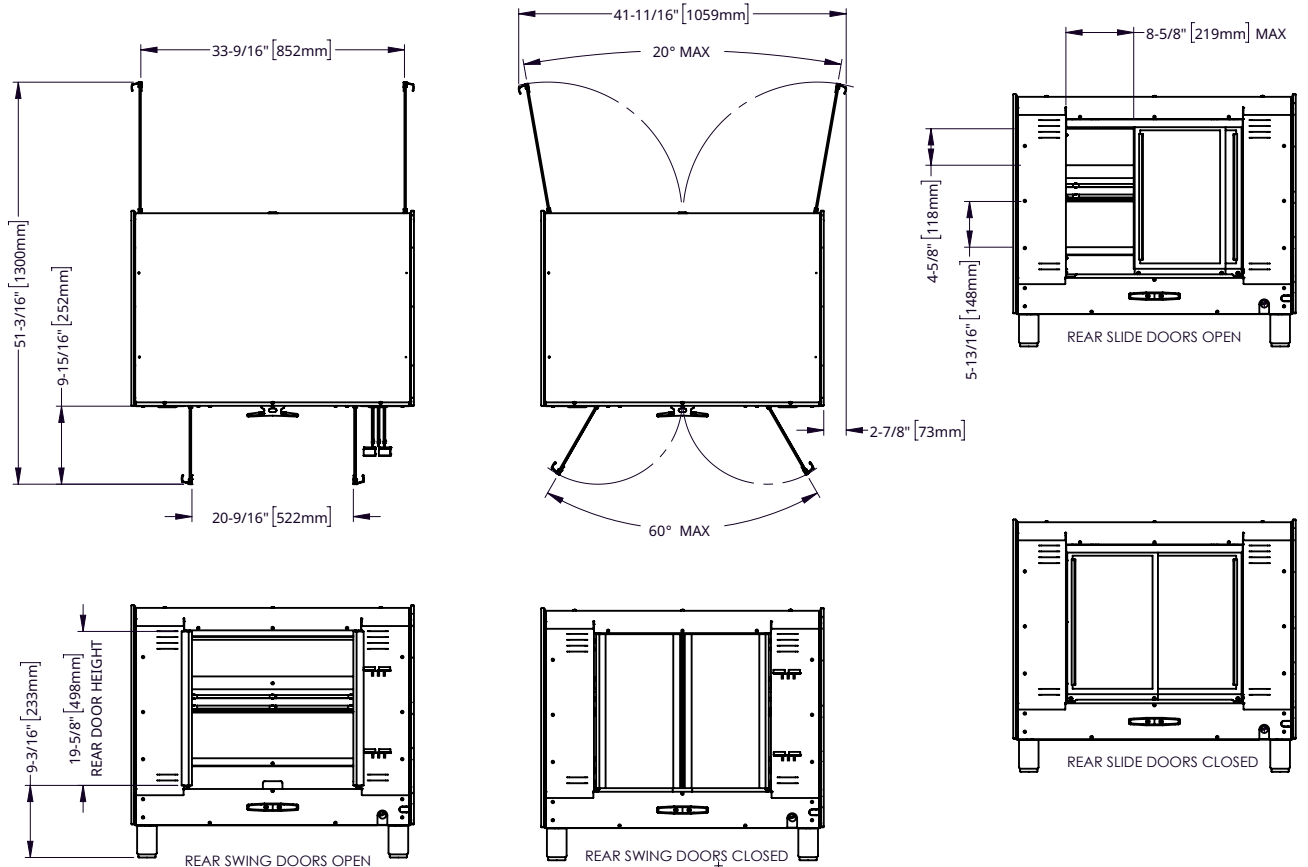
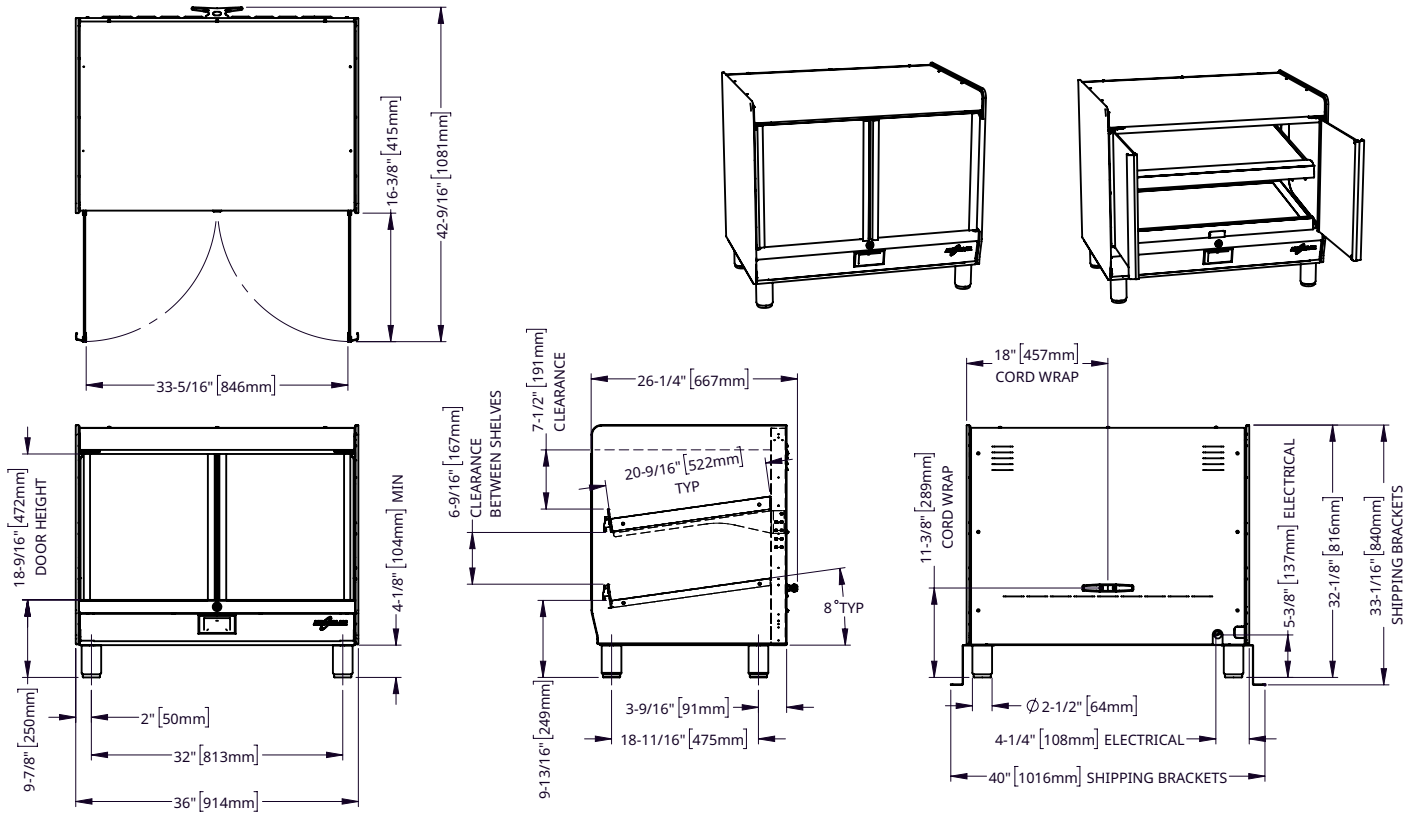

HSM Series

HSM-36/2S/T/F

ALTO-SHAAM

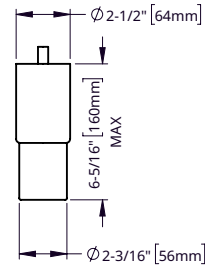
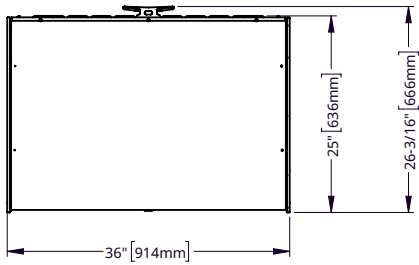

LEG DETAIL

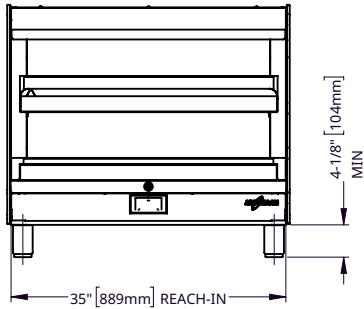
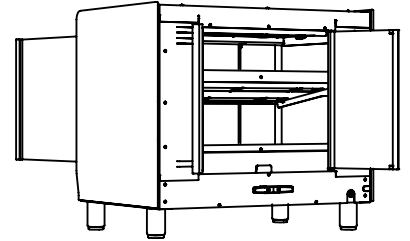

REACH-IN FRONT

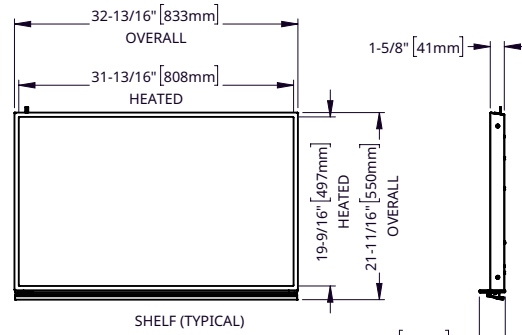

SHELF (TYPICAL)

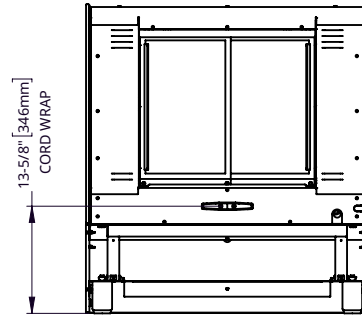
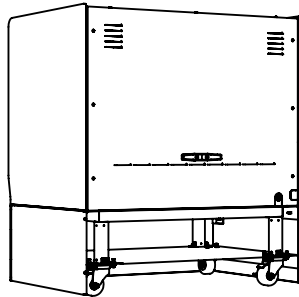
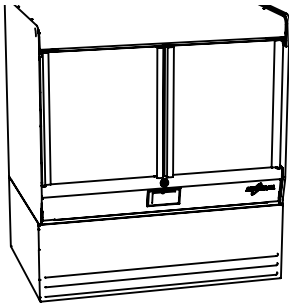
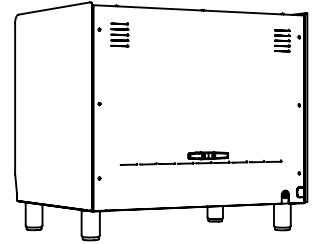
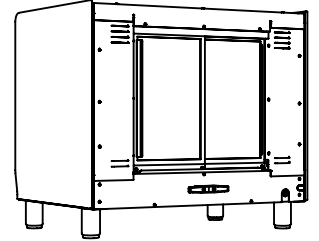

PASS THRU SLIDING DOORS REAR

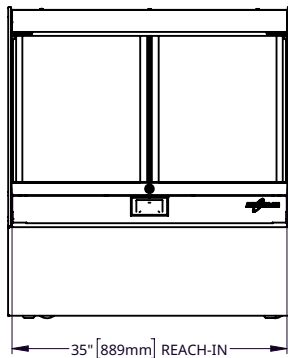

REACH-IN FRONT DOORS
DECORATIVE BASE

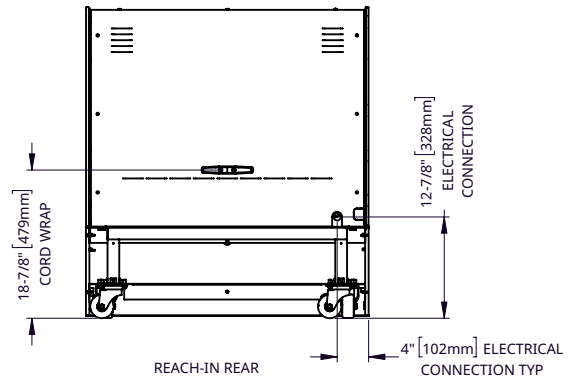
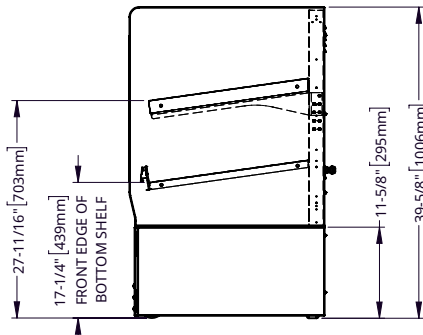

REACH-IN REAR

4" [102mm] ELECTRICAL
CONNECTION TYP

HSM Series HSM-36



Dimensions

Model	Exterior (H x W x D)
HSM-36/2S/T	35-7/8" x 36" x 27-1/4" [910mm x 914mm x 692mm]
HSM-36/2S/T/F	32-1/8" x 36" x 26-1/4" [816mm x 914mm x 667mm]
HSM-36/3S/T	54" x 36" x 27-1/4" [1372mm x 914mm x 692mm]
HSM-36/5S/T	82-1/16" x 36" x 27-1/4" [2084mm x 914mm x 692mm]

Model	Ship Dimensions (L x W x H)*
HSM-36/2S/T	56" x 45" x 64-1/2" [1422mm x 1143mm x 1638mm]
HSM-36/2S/T/F	56" x 45" x 64-1/2" [1422mm x 1143mm x 1638mm]
HSM-36/3S/T	56" x 45" x 64-1/2" [1422mm x 1143mm x 1638mm]
HSM-36/5S/T	56" x 45" x 87" [1422mm x 1143mm x 2210mm]

*Domestic ground shipping information. Contact factory for export weight and dimensions.

Net Weight
224 lb [102 kg]
224 lb [102 kg]
311 lb [141 kg]
496 lb [225 kg]

Ship Weight*
372 lb [169 kg]
372 lb [169 kg]
462 lb [210 kg]
590 lb [268 kg]

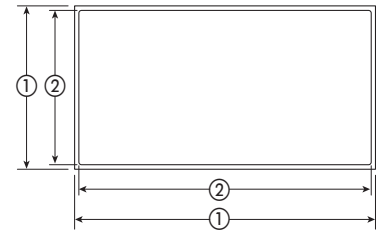

Shelf Dimensions (W x D)

① = Overall ② = Heated Surface

- ① 32-7/8" x 20-1/2" [835mm x 521mm]
- ② 31-7/8" x 19-1/2" [810mm x 495mm]



CLEARANCE

Rear: 4" [102mm]

Recommended: 18" [457mm] for service access. Charges in connection with inadequate service access is not covered under warranty.



ELECTRIC

HSM-36/2S/T/[F]	V	Ph	Hz	Awg	IEC	A	Breaker [A]	kW	Plug Configuration Options
120V	120	1	60	12	—	13.2	15	1.59	6' Cord NEMA 5-15P [USA] 6' Cord NEMA 6-20P 9' Cord, no plug
208–240V	208	1	60	12	—	5.8	15	1.2	9' Cord NEMA 6-15P 9' Cord NEMA 6-20P 9' Cord, no plug
	240	1	60	12	—	6.7	15	1.6	

Electrical connections must meet all applicable federal, state, and local codes. Dedicated circuit required.

HSM-36/3S/T	V	Ph	Hz	Awg	IEC	A	Breaker [A]	kW	Plug Configuration Options
208–240V	208	1	50/60	10	—	8.8	15	1.8	9' Cord NEMA 6-15P 9' Cord NEMA 6-20P 9' Cord, no plug
	240	1	50/60	10	—	10.0	15	2.4	

Electrical connections must meet all applicable federal, state, and local codes. Dedicated circuit required.

HSM-36/5S/T	V	Ph	Hz	Awg	IEC	A	Breaker [A]	kW	Plug Configuration Options
208–240V	208	1	50/60	8	—	14.6	25	3.0	9' Cord NEMA 6-15P 9' Cord NEMA 6-20P 9' Cord, no plug
	240	1	50/60	8	—	16.7	25	4.0	

Electrical connections must meet all applicable federal, state, and local codes. Dedicated circuit required.

CONTACT US

W164 N9221 Water Street | Menomonee Falls, Wisconsin 53051 | U.S.A.
Phone: 262.251.3800 | 800.558.8744 U.S.A./Canada | Fax: 262.251.7067 | alto-shaam.com