

## "BHS18" WALL SHELVES

*Stainless Steel, 18" Wide w/1½" Rear Riser*

### FEATURES:

- Type 300 Stainless Steel With #4 Polish, Satin Finish
- Finished With A Safety Stallion Front Edge
- 1-1/2" Turned Up Backsplash
- 18" Wide
- Shipped Knocked-Down, Easy-To-Assemble
- All Models Are NSF Certified

### SPECIFICATIONS:

- Stainless Steel Shelves Are MIG Welded
- Exposed Welds Are Polished To Match Adjacent Surface
- Shelf: Type 300 Stainless Steel With #4 Polish, Satin Finish
- Brackets: Type 300 Stainless Steel With #4 Polish, Satin Finish



### CERTIFICATIONS:



## "BHS18" STAINLESS STEEL WALL SHELVES

LENGTH	18GA	WT (LBS)	16GA	WT (LBS)	14GA	WT (LBS)
24"	BHS1824	12	BHS1824-16/304	15	BHS1824-14/304	24
36"	BHS1836	16	BHS1836-16/304	19	BHS1836-14/304	29
48"	BHS1848	19	BHS1848-16/304	24	BHS1848-14/304	35
60"	BHS1860	23	BHS1860-16/304	28	BHS1860-14/304	41
72"	BHS1872 *	28	BHS1872-16/304 *	35	BHS1872-14/304 *	52
84"	BHS1884 *	31	BHS1884-16/304 *	40	BHS1884-14/304 *	58
96"	BHS1896 *	35	BHS1896-16/304 *	44	BHS1896-14/304 *	64
108"	BHS18108 *	39	BHS18108-16/304 *	49	BHS18108-14/304 *	69
120"	BHS18120 *	42	BHS18120-16/304 *	53	BHS18120-14/304 *	74
132"	BHS18132 **	49	BHS18132-16/304 **	60	BHS18132-14/304 **	85
144"	BHS18144 **	53	BHS18144-16/304 **	66	BHS18144-14/304 **	92

\* UNITS 72"-120" ARE FURNISHED WITH 3 SUPPORT BRACKETS, \*\* UNITS 132" & 144" HAVE 4 SUPPORT BRACKETS

ALL DIMENSIONS ARE TYPICAL. TOLERANCE +/- .500". JOHN BOOS & CO. RESERVES THE RIGHT TO CHANGE SPECIFICATIONS WITHOUT NOTICE.

# DETAILED SPECIFICATIONS

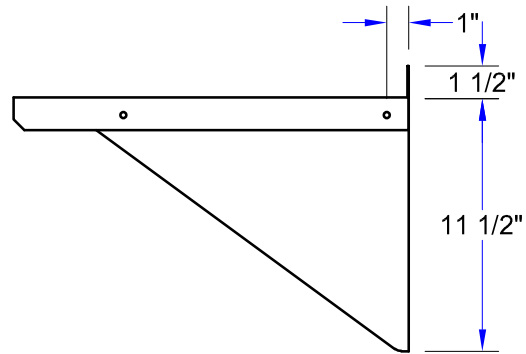
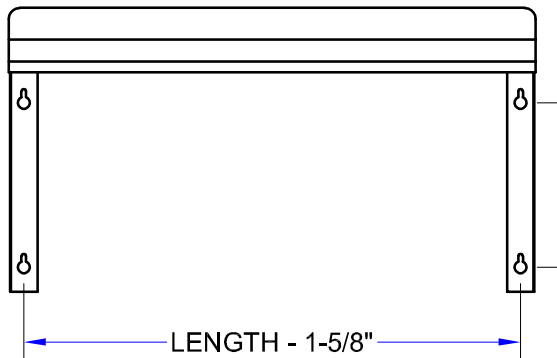
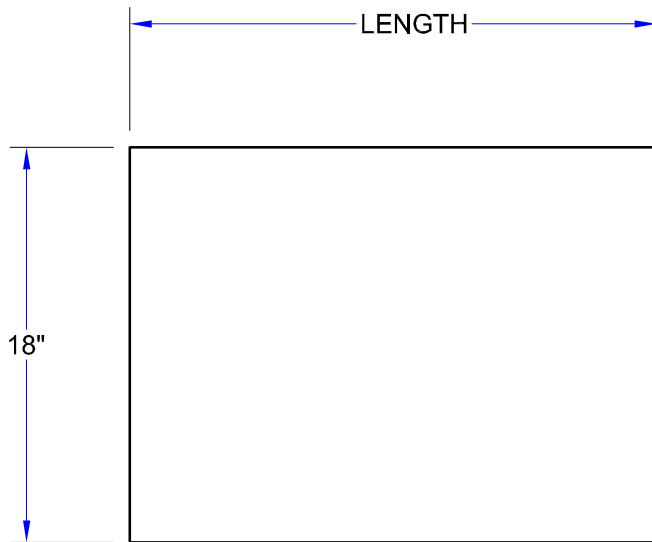

## "BHS18" STAINLESS STEEL WALL SHELVES

LENGTH	18GA	WT (LBS)	16GA	WT (LBS)	14GA	WT (LBS)
24"	BHS1824	12	BHS1824-16/304	15	BHS1824-14/304	24
36"	BHS1836	16	BHS1836-16/304	19	BHS1836-14/304	29
48"	BHS1848	19	BHS1848-16/304	24	BHS1848-14/304	35
60"	BHS1860	23	BHS1860-16/304	28	BHS1860-14/304	41
72"	BHS1872 *	28	BHS1872-16/304 *	35	BHS1872-14/304 *	52
84"	BHS1884 *	31	BHS1884-16/304 *	40	BHS1884-14/304 *	58
96"	BHS1896 *	35	BHS1896-16/304 *	44	BHS1896-14/304 *	64
108"	BHS18108 *	39	BHS18108-16/304 *	49	BHS18108-14/304 *	69
120"	BHS18120 *	42	BHS18120-16/304 *	53	BHS18120-14/304 *	74
132"	BHS18132 **	49	BHS18132-16/304 **	60	BHS18132-14/304 **	85
144"	BHS18144 **	53	BHS18144-16/304 **	66	BHS18144-14/304 **	92

\* UNITS 72"-120" ARE FURNISHED WITH 3 SUPPORT BRACKETS, \*\* UNITS 132" & 144" HAVE 4 SUPPORT BRACKETS

ALL DIMENSIONS ARE TYPICAL. TOLERANCE +/- .500". JOHN BOOS & CO. RESERVES THE RIGHT TO CHANGE SPECIFICATIONS WITHOUT NOTICE.