



BEVERAGE-AIR

Project: _____	AIA#
Item: _____	
Location: _____	SIS#
Approved: _____	

BB24HC BACK BAR REFRIGERATOR

BAR EQUIPMENT- BACK BAR REFRIGERATOR

**MODEL:
BB24HC-1-S**

BB24HC Solid Door
Hydrocarbon Series



**7 Year Parts/Labor Warranty
7 Year Compressor Warranty**

CABINET CONSTRUCTION

- Exterior is stainless steel front with continuous coil coated sides
- Interior construction utilizes galvanized steel on walls and ceiling, heavy duty stainless steel floor
- Mechanical control
- 1 ½" Stainless steel top
- Two (2) epoxy coated wire shelves
- Self-closing door with 120° stay-open feature
- Door lock
- Field reversible door (hinge kit not included)
- LED lighting
- Magnetic gaskets provide positive door seal
- Packaged products only
- 4" Heavy duty casters two (2) with locks
- Balanced, forced air refrigeration system provides rapid chilling of product

OPTIONS & ACCESSORIES

- For stainless steel interior (refer to -F models)
- Wine model (40°-60° models)
- Underbar model option
- Galvanized sub-top

REFRIGERATION SYSTEM

- Uses environmentally friendly, energy efficient R290 refrigerant, and meets all regulatory requirements for CARB, SNAP, DOE & more
- Adaptive defrost
- Epoxy coated evaporator coil
- Maintains product temperature between 36°F and 38°F



Please verify qualifying units by visiting:
www.energystar.gov/cfs



3779 Champion Blvd., Winston-Salem, NC 27105
1-888-845-9800 Fax: 1-336-245-6453
Beverage-Air.com Sales@bevair.com



BEVERAGE-AIR

MODEL	BB24HC-1-S
EXTERNAL DIMENSIONAL DATA	
Width Overall	24"
Depth Overall	30 1/8"
Height Overall with Casters	37 3/4"
Number of Doors	1
Depth with Door Open 90°	50 3/4"
Door Opening (in)	19 3/4" x 28"
INTERNAL DIMENSIONAL DATA	
NET Capacity (cubic ft.)	7.66
Internal Width Overall (in)	20"
Internal Depth Overall (in)	22 1/4"
Internal Height Overall (in)	29 1/2"
Number of Shelves	2
Number of 1/2 Kegs	1
ELECTRICAL DATA	
Full Load Amperes	2.0
REFRIGERATION DATA	
Horsepower	1/6
Capacity (BTU/Hr)	1094
Heat Rejection (BTU/Hr)	1641
Charge (lbs/grams/ounces)	0.1213 / 55 / 1.94
SHIPPING DATA	
Gross Weight - Crated	188 lbs
Height - Crated	46"
Width - Crated	27"
Depth - Crated	32"

*NOTE: Remote units are field wired and come with 6" legs.
Refrigerant must be specified at time of order.

We reserve the right to change specifications and product design without notice. Such revisions do not entitle the buyer to corresponding changes, improvements, additions or replacements for previously purchased equipment. Dimensional tolerances +/- 1/4". Metric dimensions (MM).

Bar Equipment-Back Bar Refrigerator Model: BB24HC-1-S

Model Views

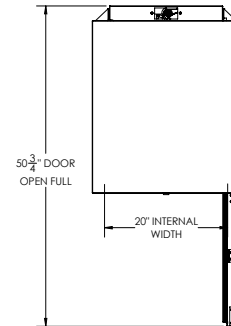

PLAN VIEW

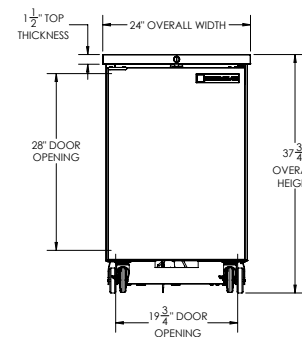

ELEVATION VIEW

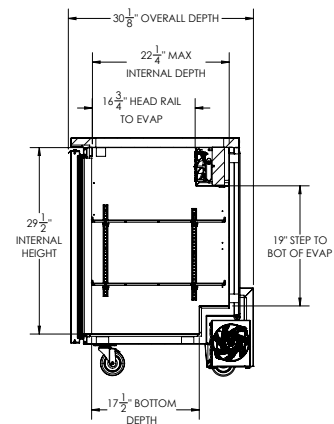

SIDE VIEW



ELECTRICAL CONNECTION

115/60/1
NEMA 5-15P

Unit pre-wired at factory
and include 8' long cord
and plug set.