

"EBSS6" ENCLOSED BASE WORK TABLES

16GA Stainless Steel Top - Sliding Doors

FEATURES:

- 16GA Stainless Steel Flat Top
- Sliding Door Style
- Type 300 Stainless Steel With #4 Polish, Satin Finish
- Top Is Sound Deadened
- Reinforced With 1"x2" Channel Running Entire Length Of Table
- 1-1/2" Stallion Edge On Front And Rear With Side Edges 90 Degree Bend Down For Table Line-Up
- Stainless Steel Base And Undershef
- Undershef Is Secured In A Fixed Position, 10" Above Floor
- Shipped Standard Welded Set-Up

SPECIFICATIONS:

- Top: Stainless Steel Tops Are TIG Welded, Exposed Welds Are Polished To Match Adjacent Surface
- Top: 16GA Stainless Steel Type 300 Stainless Steel With #4 Polish, Satin Finish
- Shelf: 18GA Type 300 Stainless Steel, #4 Polish With Satin Finish
- Legs: 1-1/2" Square O.D., 16GA Tubular Stainless Steel
- Panels: 20GA Type 300 Stainless Steel, #4 Polish With Satin Finish
- Feet: 1" Adjustable Stainless Steel Bullet Feet



EBSS6-3072

CERTIFICATIONS:



ACCESSORIES

MODEL	DESCRIPTION
EBRS	Removable Intermediate Shelf - All Sizes

"EBSS6" ENCLOSED BASE WORK TABLES

LENGTH	# OF LEGS	24" WIDTH	WEIGHT (LBS)	30" WIDTH	WEIGHT (LBS)
36"	4	EBSS6-2436	140	EBSS6-3036	145
48"	4	EBSS6-2448	145	EBSS6-3048	162
60"	4	EBSS6-2460	207	EBSS6-3060	224
72"	4	EBSS6-2472	232	EBSS6-3072	248
84"	6	EBSS6-2484	268	EBSS6-3084	285
96"	6	EBSS6-2496	303	EBSS6-3096	320
108"	6	EBSS6-24108	327	EBSS6-30108	350
120"	6	EBSS6-24120	351	EBSS6-30120	380
132"	6	EBSS6-24132	375	EBSS6-30132	410
144"	6	EBSS6-24144	400	EBSS6-30144	440

ALL DIMENSIONS ARE TYPICAL. TOLERANCE +/- .500". JOHN BOOS & CO. RESERVES THE RIGHT TO CHANGE SPECIFICATIONS WITHOUT NOTICE.

DETAILED SPECIFICATIONS

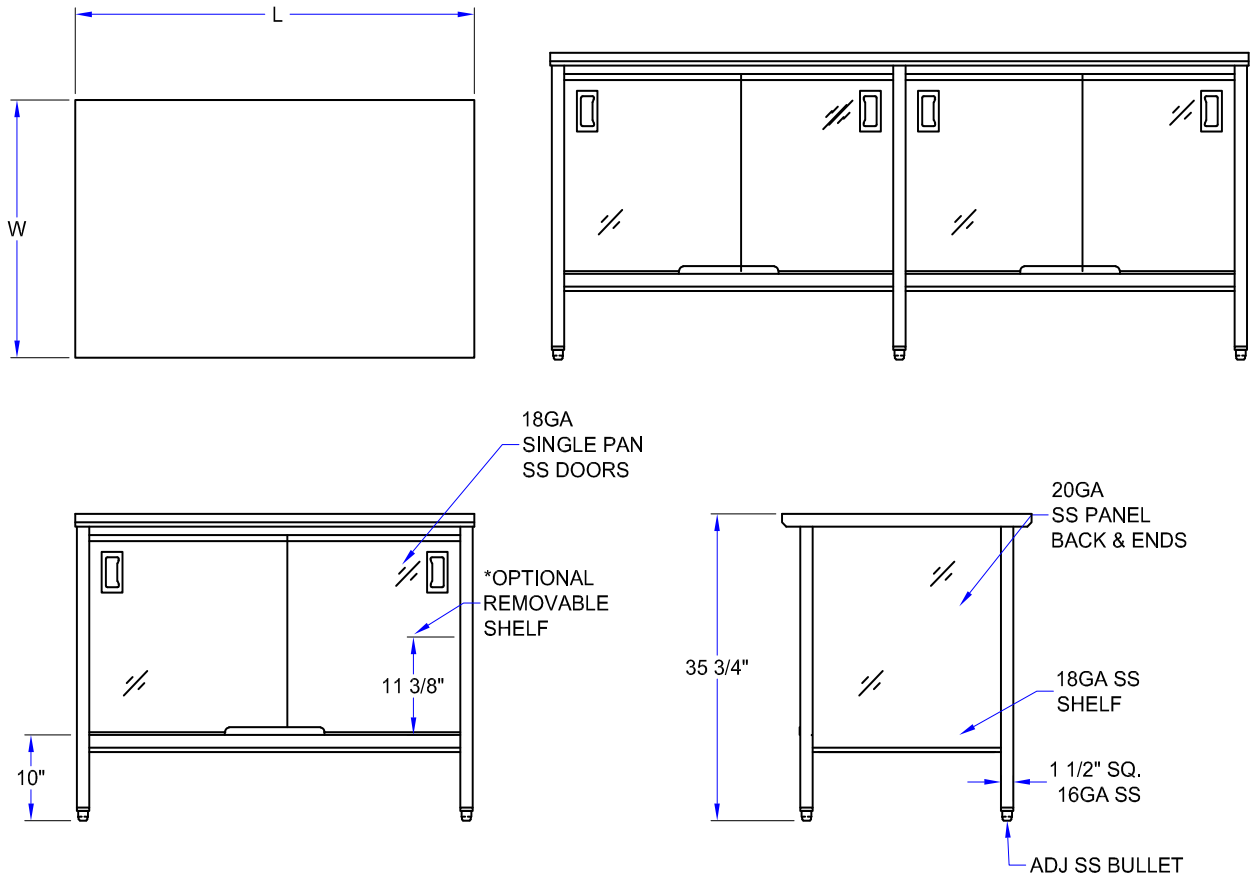

MODEL # STRUCTURE

S = Stainless Steel
 S = Sliding Doors
 EB = Enclosed Base

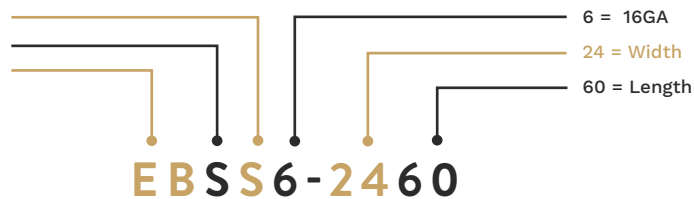

"EBSS6" ENCLOSED BASE WORK TABLES

LENGTH	# OF LEGS	24" WIDTH	WEIGHT (LBS)	30" WIDTH	WEIGHT (LBS)
36"	4	EBSS6-2436	140	EBSS6-3036	145
48"	4	EBSS6-2448	145	EBSS6-3048	162
60"	4	EBSS6-2460	207	EBSS6-3060	224
72"	4	EBSS6-2472	232	EBSS6-3072	248
84"	6	EBSS6-2484	268	EBSS6-3084	285
96"	6	EBSS6-2496	303	EBSS6-3096	320
108"	6	EBSS6-24108	327	EBSS6-30108	350
120"	6	EBSS6-24120	351	EBSS6-30120	380
132"	6	EBSS6-24132	375	EBSS6-30132	410
144"	6	EBSS6-24144	400	EBSS6-30144	440

ALL DIMENSIONS ARE TYPICAL. TOLERANCE +/- .500". JOHN BOOS & CO. RESERVES THE RIGHT TO CHANGE SPECIFICATIONS WITHOUT NOTICE.