

# Champion<sup>®</sup>

## Service Replacement Parts



### Two Tank Rack Conveyor Dishwasher

Models	
64 PRO	86 PRO
90FF PRO	
100HD PRO	



Issue Date: 5.11.20

Manual P/N 116083 rev. E

For machines beginning with S/N D19051979 and above

3765 Champion Boulevard  
Winston-Salem, NC 27105  
(336) 661-1556 Fax: (336) 661-1660  
Toll-free: 1 (800) 858-4477

2674 N. Service Road, Jordan Station  
Ontario, Canada L0R 1S0  
(905) 562-4195 Fax: (905) 562-4618  
Toll-free: 1( 800) 263-5798

Printed in the USA



NATIONAL SERVICE DEPARTMENT

USA

Toll-free: 1-800-858-4477  
Tel: (336) 661-1556  
Fax: (336) 661-1660  
Email: [service@championindustries.com](mailto:service@championindustries.com)

Canada

Toll-free: 1-800-263-5798  
Tel: (905) 562-4195  
Fax: (905) 562-4618  
Email: [service@moyerdiebellimited.com](mailto:service@moyerdiebellimited.com)

ATTENTION

The machine data plate  
is located on the side of  
upper control panel.



**Two ways to  
REGISTER YOUR PRODUCT and  
ACTIVATE YOUR WARRANTY.**

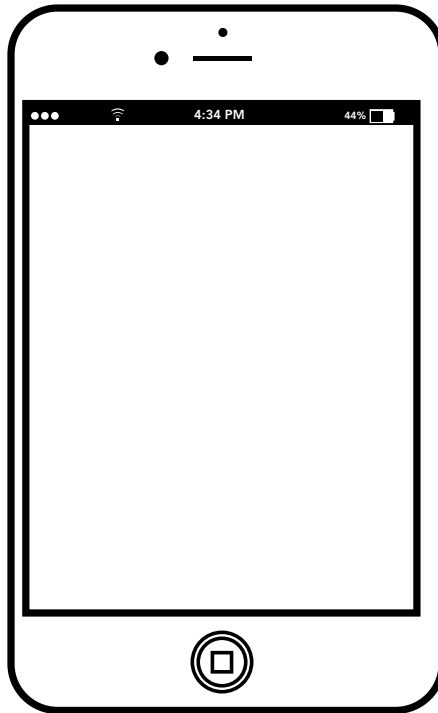

- Use your mobile device and connect to the website [www.championindustries.com](http://www.championindustries.com) to register your product.
- Complete the fax form on the next page and fax to 1-800 661-1660.

# PRODUCT REGISTRATION BY FAX

COMPLETE THIS FORM AND FAX TO:

(336) 661-1660 in the USA

1-(800) 204-0109 in Canada

## PRODUCT REGISTRATION CARD

Model
-------

Serial #
----------

Date of Installation: \_\_\_/\_\_\_/\_\_\_

Company Name: \_\_\_\_\_

Address: \_\_\_\_\_  
(Street) State/Province Zip/Postal Code

Telephone #: ( ) \_\_\_\_\_ --- \_\_\_\_\_

Contact: \_\_\_\_\_

Installation Company: \_\_\_\_\_

Address: \_\_\_\_\_

Telephone #: \_\_\_\_\_

Contact: \_\_\_\_\_

**FAILURE TO REGISTER YOUR PRODUCT MAY VOID YOUR WARRANTY**

**IMPORTANT IMPORTANT**

# Revision History

Specifications are subject to change based on continual product improvement.

<i>Revision Date</i>	<i>Revised Pages</i>	<i>Serial Number Effectivity</i>	<i>Revision Description</i>
10.8.19	All	RP19051979	Released first edition
11.6.19	22-23	All	Revised final rinse assy.
12.20.19	66-67	All	Revised ION assembly
	68-69	All	Revised pump/motor assembly
	70-71	All	Revised pump installations
1.26.20	12-13	RP20012488	Added clutch continual drive assembly
2.10.20	4-5	RP19051979 to S/N RP20012488	Current transformer replaced by new clutch assembly a S/N RP20012488
5.11.20	53	All	Changed Item 15 to P/N 113604

## Limited Warranty

# LIMITED WARRANTY

Champion Industries (herein referred to as "The Company"), 3765 Champion Blvd., Winston-Salem, North Carolina 27105, and 2674 N. Service Road, Jordan Station, Ontario, Canada, L0R 1S0, warrants machines, and parts, as set out below.

**Warranty of Machines:** The Company warrants all new machines of its manufacture bearing the name "Champion and installed within the United States and Canada to be free from defects in material and workmanship for a period of one (1) year after the date of installation or fifteen (15) months after the date of shipment by The Company, whichever occurs first. [See below for special provisions relating to glasswashers.] Warranty registration must be submitted to The Company within ten (10) days after installation either online on the Champion Industries website (<http://www.champion-industries.com>) or by the fax form provided at the front of this manual. The Company will not assume any responsibility for extra costs for installation in any area where there are jurisdictional problems with local trades or unions.

If a defect in workmanship or material is found to exist within the warranty period, The Company, at its election, will either repair or replace the defective part or accept return of the machine for full credit; provided; however, as to glasswashers, The Company's obligation with respect to labor associated with any repairs shall end (a) 120 days after shipment, or (b) 90 days after installation, whichever occurs first. In the event that The Company elects to repair, the labor and work to be performed in connection with the warranty shall be done during regular working hours by a Champion authorized service technician. Defective parts become the property of The Company. Use of replacement parts not authorized by The Company will relieve The Company of all further liability in connection with its warranty. In no event will The Company's warranty obligation exceed The Company's charge for the machine. The following are not covered by The Company's warranty:

- a. Lighting of gas pilots or burners.
- b. Cleaning of gas lines.
- c. Replacement of fuses or resetting of overload breakers.
- d. Adjustment of thermostats.
- e. Adjustment of clutches.
- f. Opening or closing of utility supply valves or switching of electrical supply current.
- g. Cleaning of valves, strainers, screens, nozzles, or spray pipes.
- h. Performance of regular maintenance and cleaning as outlined in the operator's guide.
- i. Damages resulting from water conditions, accidents, alterations, improper use, abuse, tampering, improper installation, or failure to follow maintenance and operation procedures.
- j. Wear on Pulper cutter blocks, pulse vanes, and auger brush.

Examples of the defects not covered by warranty include, but are not limited to: (1) Damage to the exterior or interior finish as a result of the above, (2) Use with utility service other than that designated on the rating plate, (3) Improper connection to utility service, (4) Inadequate or excessive water pressure, (5) Corrosion from chemicals dispensed in excess of recommended concentrations, (6) Failure of electrical components due to connection of chemical dispensing equipment installed by others, (7) Leaks or damage resulting from such leaks caused by the installer, including those at machine table connections or by connection of chemical dispensing equipment installed by others, (8) Failure to comply with local building codes, (9) Damage caused by labor dispute.

**Warranty of Parts:** The Company warrants all new machine parts produced or authorized by The Company to be free from defects in material and workmanship for a period of 90 days from date of invoice. If any defect in material and workmanship is found to exist within the warranty period The Company will replace the defective part without charge.

**DISCLAIMER OF WARRANTIES AND LIMITATIONS OF LIABILITY. THE COMPANY'S WARRANTY IS ONLY TO THE EXTENT REFLECTED ABOVE. THE COMPANY'S MAKE NO OTHER WARRANTIES, EXPRESS OR IMPLIED, INCLUDING, BUT NOT LIMITED, TO ANY WARRANTY OF MERCHANTABILITY, OR FITNESS OF PURPOSE. THE COMPANY SHALL NOT BE LIABLE FOR INCIDENTAL OR CONSEQUENTIAL DAMAGES. THE REMEDIES SET OUT ABOVE ARE THE EXCLUSIVE REMEDIES FOR ANY DEFECTS FOUND TO EXIST IN THE COMPANY'S DISHWASHING MACHINES AND THE COMPANY'S PARTS, AND ALL OTHER REMEDIES ARE EXCLUDED, INCLUDING ANY LIABILITY FOR INCIDENTALS OR CONSEQUENTIAL DAMAGES.**

The Company does not authorize any other person, including persons who deal in Champion dishwashing machines to change this warranty or create any other obligation in connection with Champion dishwashing machines.

# Service Replacement Parts

ILLUSTRATION	PAGE
Control Cabinet.....	2
Controls.....	4
Junction Box.....	6
Conveyor Assembly.....	8
Continual Drive Assembly.....	10
Clutch Style Continual Drive Assembly.....	12
Power Rinse Drain Assembly.....	14
Wash Tank Drain Assembly without Prewash.....	16
Wash Tank Drain Assembly with Prewash.....	18
Fill Hoses.....	20
Power Rinse Fill Assembly.....	22
Wash Fill Assembly.....	24
L-R Final Rinse Assembly.....	26
L-R Final Rinse Piping Assembly.....	28
L-R Main Connect Assembly.....	30
22" Prewash Door Assembly.....	32
36" Prewash Door Assembly.....	34
Wash Door Assembly.....	36
Tank Panels, and Curtains.....	38
Tank Floats and Thermistors.....	40
Left-hand Wash Arm Assembly.....	42
Right-hand Wash Arm Assembly.....	44
22" and 36" Prewash Panels and Curtains.....	46
22" and 36" Prewash Spray Arms.....	48
Wash/Power Rinse Tank Heaters.....	50
Electric Booster.....	52
External Steam Booster Cabinet beginning with S./N 18101727.....	54
External Steam Booster Piping Assembly beginning with S./N 18101727.....	56
Steam Coils and Piping.....	58
Heat Recovery Unit Coil.....	60
Heat Recovery Unit Standard Hood Vent Cowl.....	62
Heat Recovery Unit High Hood Vent Cowl.....	64
Standard Vent Cowl/ Splash Shields.....	66
Ion Water Conditioner/Drain Water Tempering Kit.....	68
Wash/Pewash Pump/Motor.....	70
Pump Installations.....	72
Dish Racks.....	74

# Control Cabinet

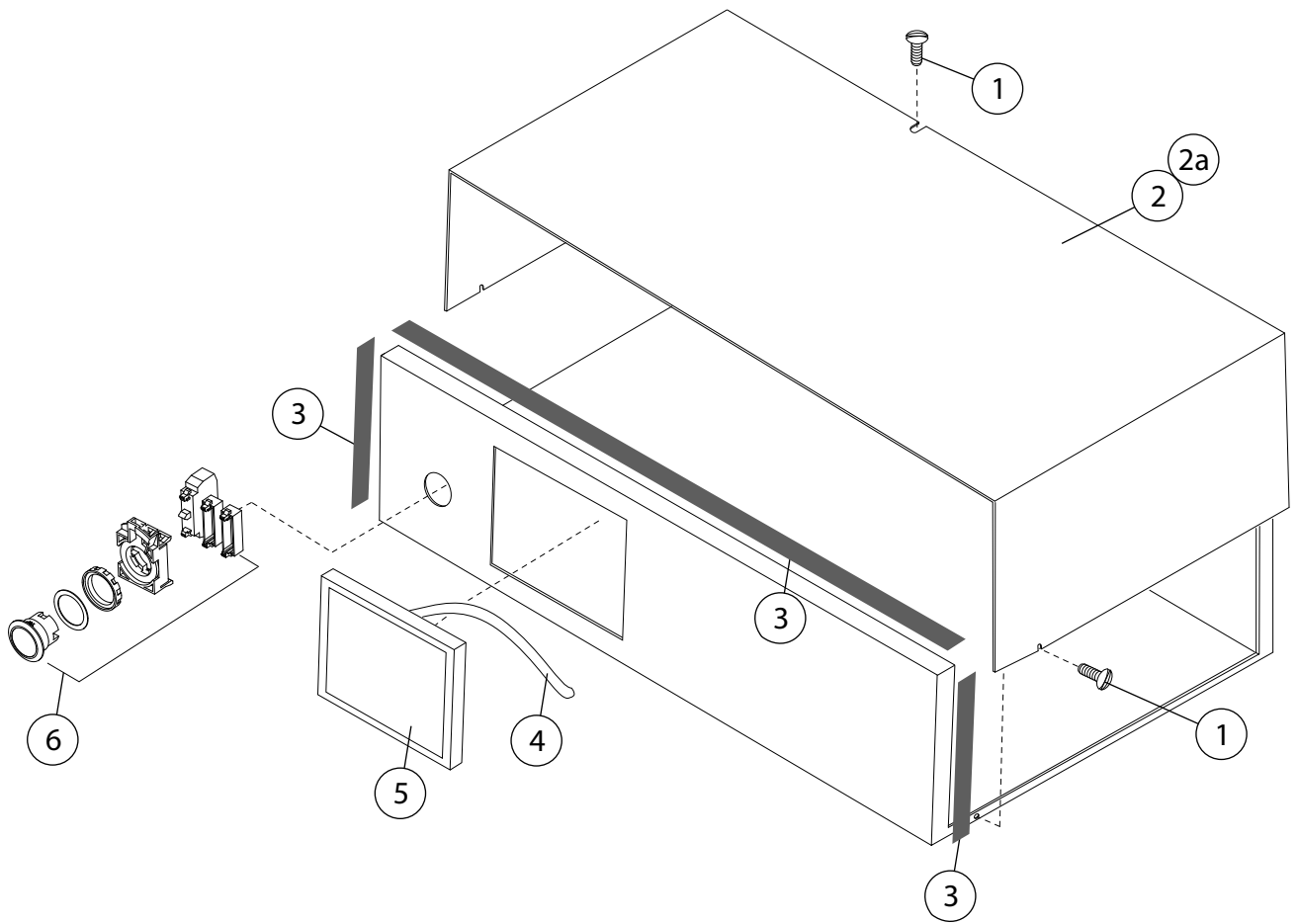



Item No.	Part No.	Description	Qty.
1	100007	SCREW, 10-32 X 3/8" TRUSS HEAD	3
2	339380	COVER, CABINET 36"	1
2A	337563	COVER, CABINET 40"	1
3	107431	GASKET, STEAM	5 FT.
4	116919	CABLE, HMI TO PLC	1
5	116888	PLC, SCHNEIDER, TM221CE24R	1
6	116852	PUSH BUTTON, GREEN, FLUSH, 22MM ENGRAVED	1

# Controls

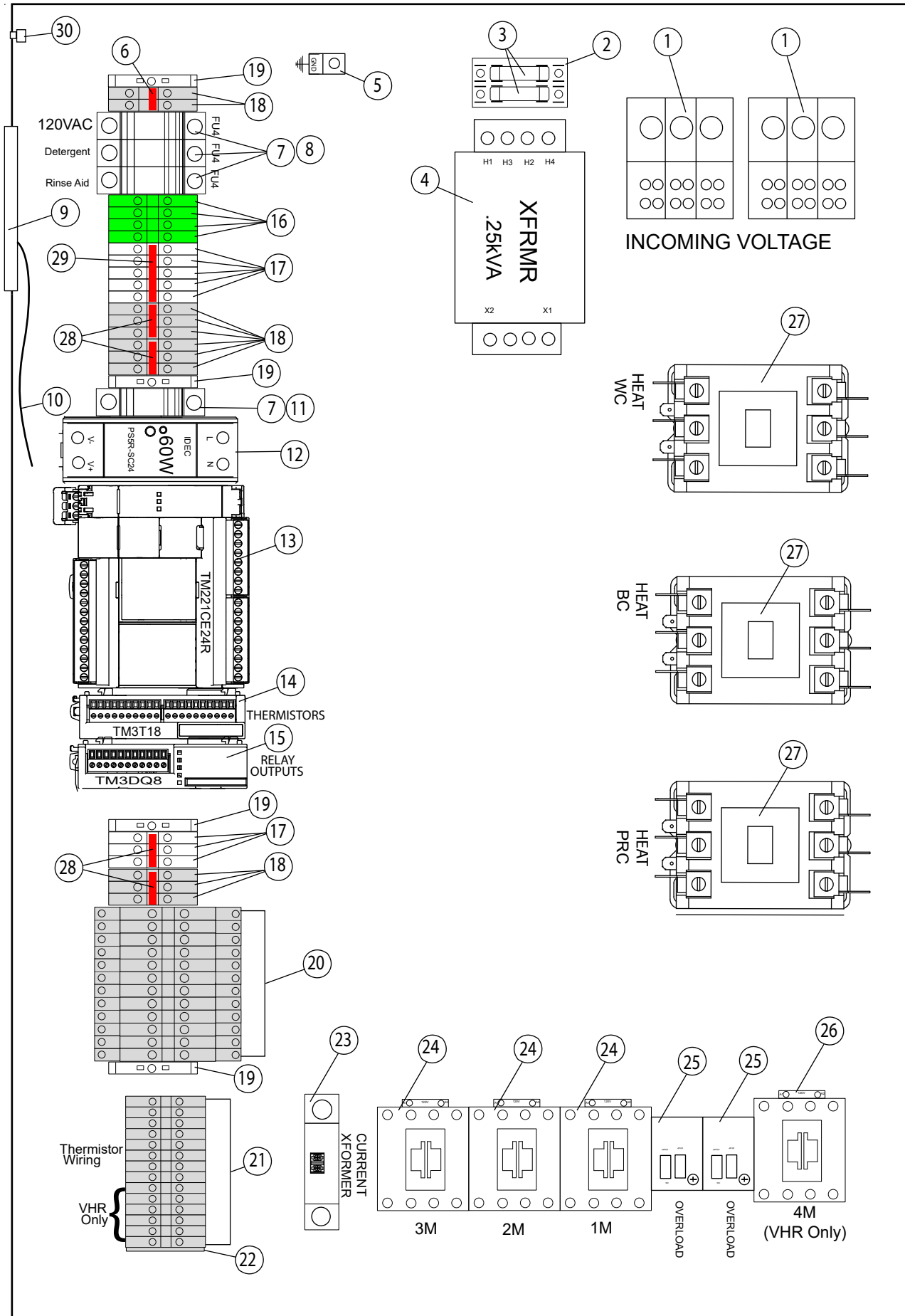

Item No.	Part No.	Description	Qty.
1	111833	BLOCK, INPUT TERMINAL, 175A, 3-POLE	1
2	112424	BLOCK, FUSE KIT	1
3	112482	FUSE, 3.5A, 208-240V/60/ 1 & 3	2
3a	112484	FUSE, 1.5A 460-480V, 380-415V, 575V	2
4	109064	TRANSFORMER, 250VA	1
5	103310	LUG, GROUND	1
6	114523	BRIDGE, 2-POLE, FBS 2-5	2
7	111153	BLOCK, FUSE	4
8	116213	FUSE, LPCC 0.5A	3
9	116889	HMI, SCHNEIDER PRO FACE	1
10	116919	CABLE, NETWORK, PLC TO HMI	1
11	112901	FUSE, LPCC 1.0A	1
12	116967	POWER SUPPLY, 60W, IDEC	1
13	116888	PLC, SCHNEIDER, TM221CE24R	1
14	116891	MODULE, SCHNEIDER THERMISTER, TM3T18	1
15	116934	MODULE, RELAY OUTPUT, 8PT, SCHNEIDER TM3DQ8	1
16	114515	TERMINAL, SINGLE GROUND, ST 2.5 PE, GREEN	4
17	114514	TERMINAL, SINGLE ST 2.5 WHITE	8
18	114512	TERMINAL, SINGLE, ST 2.5 GRAY	9
19	114519	BLOCK, END E/NS 35 N	4
20	114517	TERMINAL, DOUBLE STTB 2.5	12
21	114520	TERMINAL, SINGLE, MZB 1.5 NS35	14
22	114516	END COVER, SINGLE TERMINAL, D-ST 2.5	1
23	116802	CURRENT, DWYER (From S/N RP19051979 to S/N RP20012488)	1
24	108122	CONTACTOR, 12A	3
25	111624	OVERLOAD, MOTOR STARTER, 0.63 - 1.0A	2
26	116634	CONTACTOR, LC1D32G7, 120VAC COIL	1
27	116166	CONTACTOR, 60 FLA, 3-POLE, 120VAC COIL	3
28	114524	BRIDGE, 3-POLE, FBS 3-5	4
29	114823	BRIDGE, 4-POLE, FBS 4-5	1
30	116852	PUSH BUTTON, GREEN, FLUSH, 22MM ENGRAVED	1

Junction Box

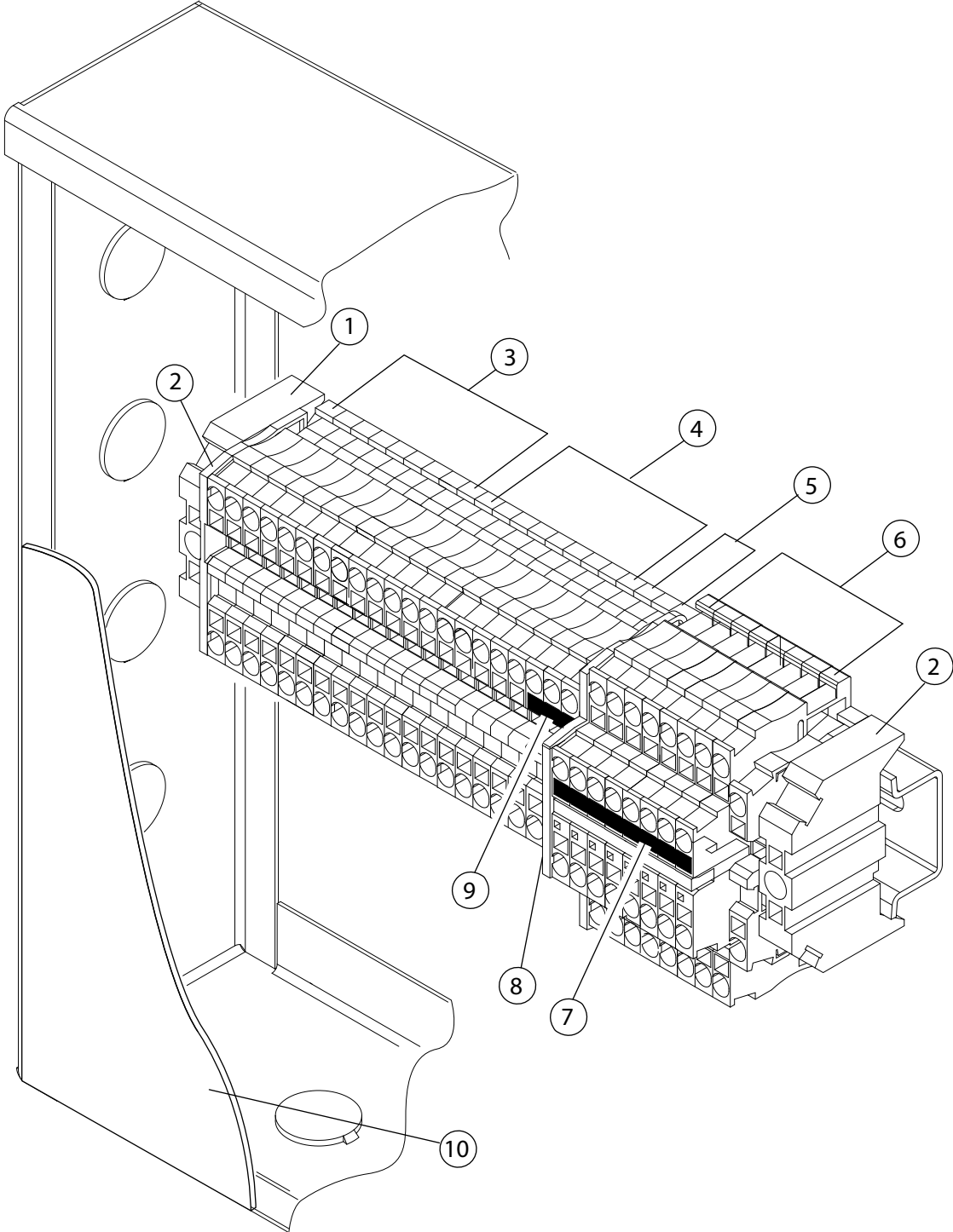

Item No.	Part No.	Description	Qty.
1	114519	END BLOCK, E/NS 35N	2
2	114516	END COVER, SINGLE TERMINAL D-ST-2.5	1
3	114513	TERMNAL, SINGLE ST 2.5 BU (BLUE)	9
4	114512	TERMINAL, SINGLE ST 2.5 (GRAY)	9
5	114514	TERMINAL, SINGLE ST 2.5 WH, (WHITE)	3
6	114517	TERMINAL, DOUBLE STTB 2.5	9
7	114522	BRIDGE, 10 POLE FBS 10-5	1
8	114518	END COVER, DOUBLE TERMINAL D-STTB 2.5	1
9	114524	BRIDGE, 3 POLE FBS 3-5	1
10	337582	COVER, ENCLOSURE	1
---	114520	THERMISTOR TERMINAL BLOCK (NOT SHOWN) TERMINAL SINGLE MZB 1.5 NS35	4

## NOTE:

TERMINAL BLOCK QUANTITIES MAY VARY DEPENDING ON MACHINE OPTIONS.

# Conveyor Assembly

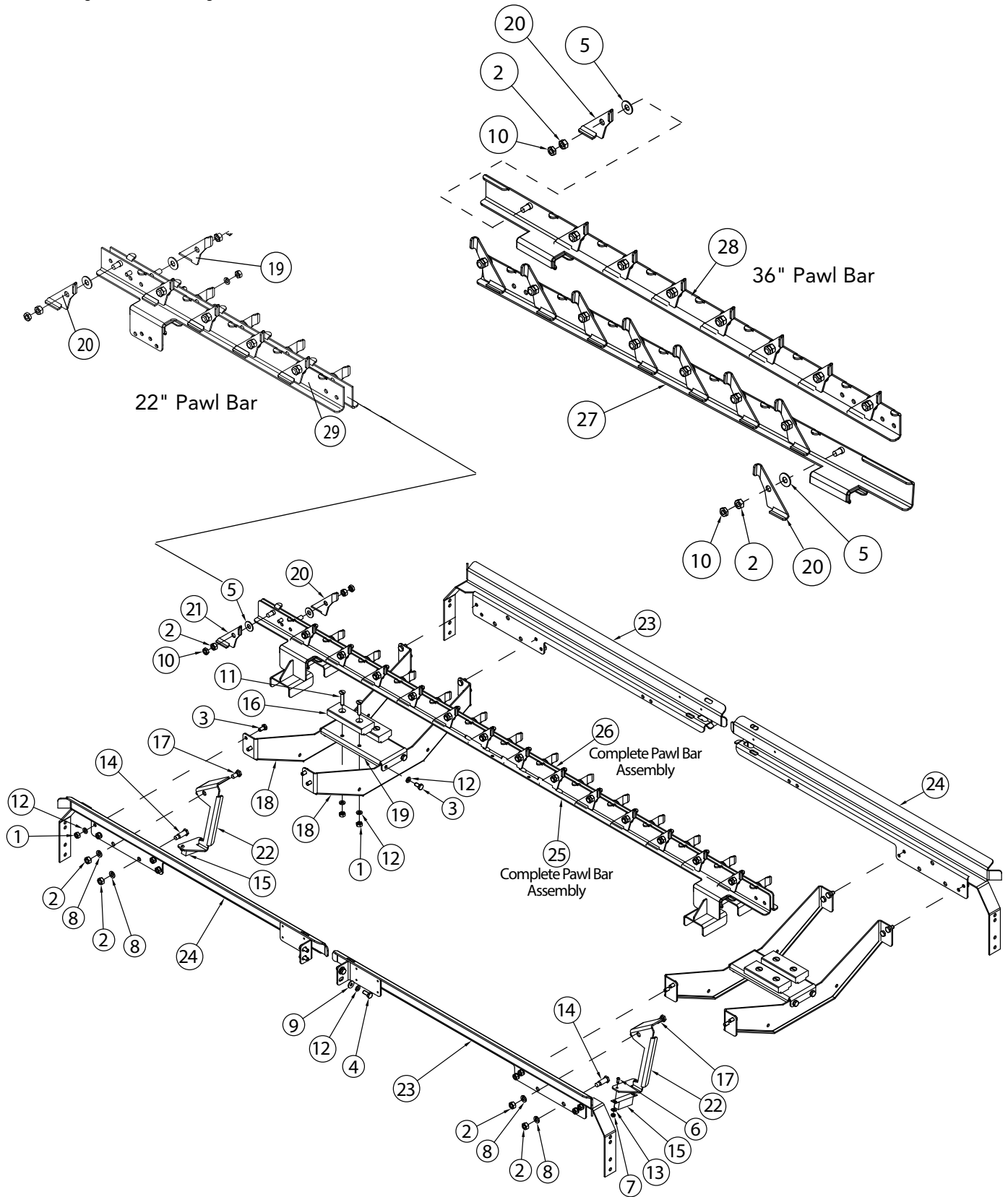

Item No.	Part No.	Description	Qty.
1	100003	HEX PLAIN NUT, 1/4-20 SST	24
2	100154	HEX PLAIN NUT, 5/16-18 SST	32
3	100734	BOLT, HEX HEAD 1/4-20 X 1/2" SST	24
4	100735	BOLT, HEX HEAD, 1/4-20 X 5/8" SST	4
5	104618	WASH, FLAT, 3/8"	28
6	104883	SCREW, ROUND HEAD, 6-32 X 3/8" SST	4
7	104971	HEX GRIP NUT, 6-32 SST	4
8	106013	WASHER, LOCK, 5/16" SPLIT, SST	4
9	106026	WASHER, FLAT, 1/4" SST	4
10	106198	HEX PLAIN JAM NUT, 5/16-18 SST	28
11	106474	SCREW, FLAT HEAD, 1/4-20 X 1-1/4" SST	8
12	106482	WASHER, LOCK 1/4" SPLIT SST	36
13	107033	WASHER, FLAT, SST	4
14	113692	BOLT SHOULDER 3/8" X 3/4" X 5/16-18 X 3/8" SST	2
15	113937	MAGNET, REED SWITCH	2
16	116333	BEARING, BLOCK, UHMW	4
17	116470	BOLT, SHOULDER 3/8" X 1/8" X 5/16-18 X 1/2" SST	2
18	337302	CROSSRAIL, SUPPORT, DEVP., PRO	4
19	337303	CROSSRAIL, DEVP., BEARING MOUNT, V2	2
20	337602-1	PAWL, FRONT, RL, PRO RACK, V2	14
21	337602-2	PAWL, FRONT, LR, PRO RACK, FAS	14
22	338180-1	IDLE/FINAL RINSE LEVER, LR, M1 PRO RACK	2
23	339466	TRACK, WELD, 64 PRO, LH-RR OR RH-RR	2
24	339467	TRACK WELD, 64 PRO, LH-FR OR RH-FR	2
25	420570	PAWL BAR ASSY., ROLL DR, 64 PRO, LR-FR OR RL-RR	1
26	420571	PAWL BAR ASS., ROLL DR, 64 PRO, LR-RR OR RL-FR	1
27	338271	PAWL BAR WELD., 36" LH, PREWASH	1
28	338272	PAWL BAR WELD., 36" RH, PREWASH	1

# Continual Drive Assembly

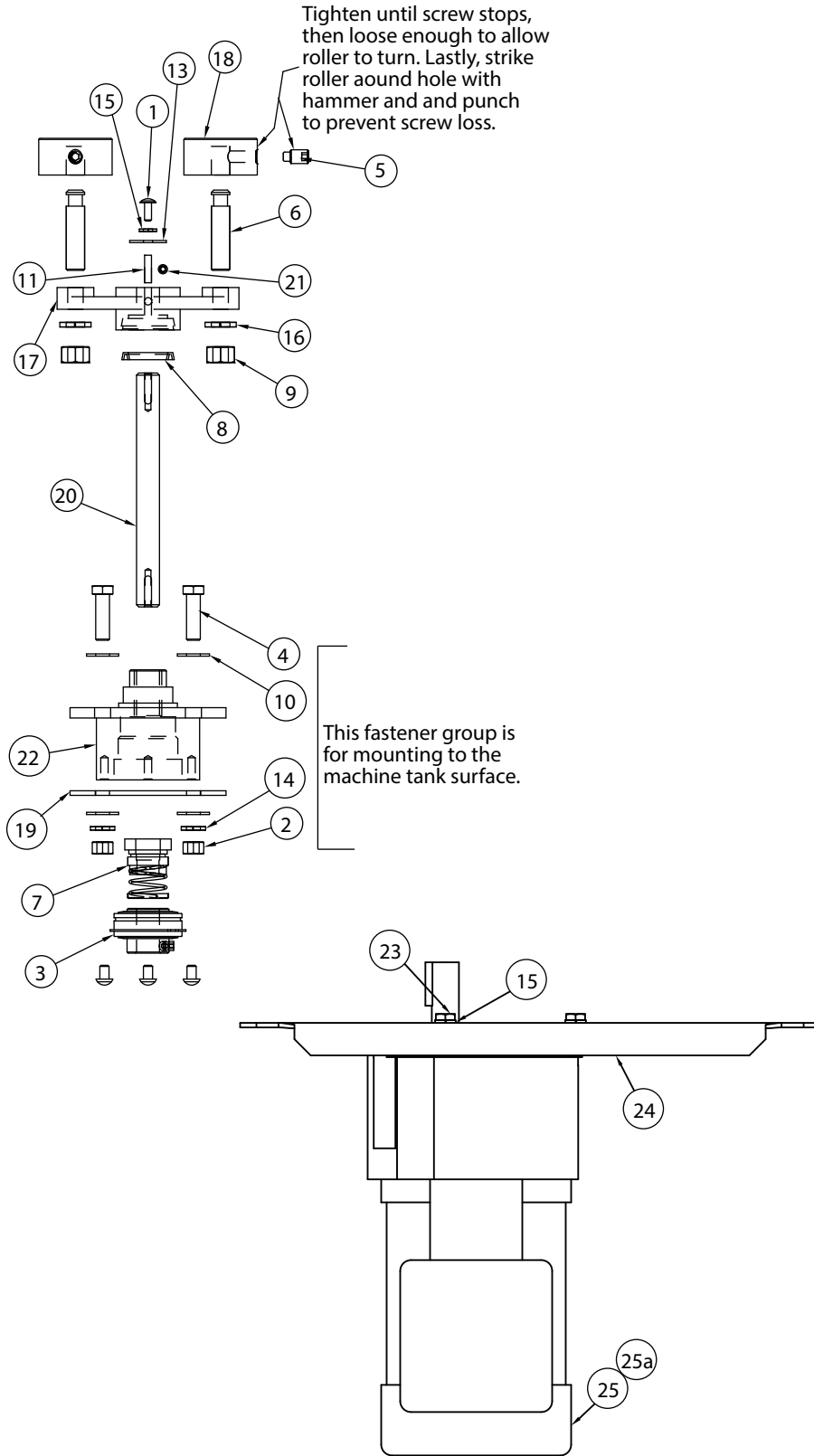



Item No.	Part No.	Description	Qty.
1	100097	SCREW, TRUSS HEAD, 10-32 X 1/2" SST	1
2	100140	HEX PLAIN NUT, 3/8-16 SST	4
3	100382	BEARING, RACK, DRIVE	1
4	100746	BOLT, HEX HEAD, 3/8-16 X 1-1/4" SST	4
5	100769	SCREW SET 3/8-16 X 3/4", DOG POINT	2
6	100868	ROLLER, STUD, CROSSHEAD	2
7	102244	SEAL, 5/8", 2-PIECE	1
8	103180	WIPER RING, CRANK, RACKS	1
9	104584	HEX PLAIN NUT, 1/2-13 SST	2
10	104618	WASHER, FLAT 3/8" SST	8
11	104916	KEY, 3/16" X 3/16" X 3/4" SST	1
12	104923	SCREW, ROUND HEAD, 1/4-20 X 3/8" SST	4
13	104925	WASHER, FLAT, 1/4" SST	1
14	106407	WASHER, LOCK, 3/8" SPLIT, SST	4
15	106482	WASHER, LOCK 1/4" SPLIT, SST	2
16	107589	WASHER, LOCK, 1/2" SPLIT, SST	1
17	116932	DRIVE, CRANK CASTING	2
18	202381	ROLLER, CROSSHEAD, RACK MACHINE	2
19	206303	GASKET, BEARING HOUSING	1
20	207430	SHAFT, DRIVE, V2 RACK	1
21	0501395	SET SCREW, 1/4-20 X 5/16" SST	1
22	B1074-1	BEARING, HOUSING, WITH BUSHING	1
23	100734	BOLT, HEX HEAD, 1/4-20 X 1/2" SST	3
24	339371	BRACKET, CONTINUAL DRIVE MTR. SUPPORT, 2-T	1
25	116810	GEARMOTOR, 1/6HP, MV/3PH, 27.2 RPM	A/R
25a	116908	GEARMOTOR, 1/6HP, 575/3PH, 27.2 RPM	A/R

# Clutch Style Continual Drive Assembly

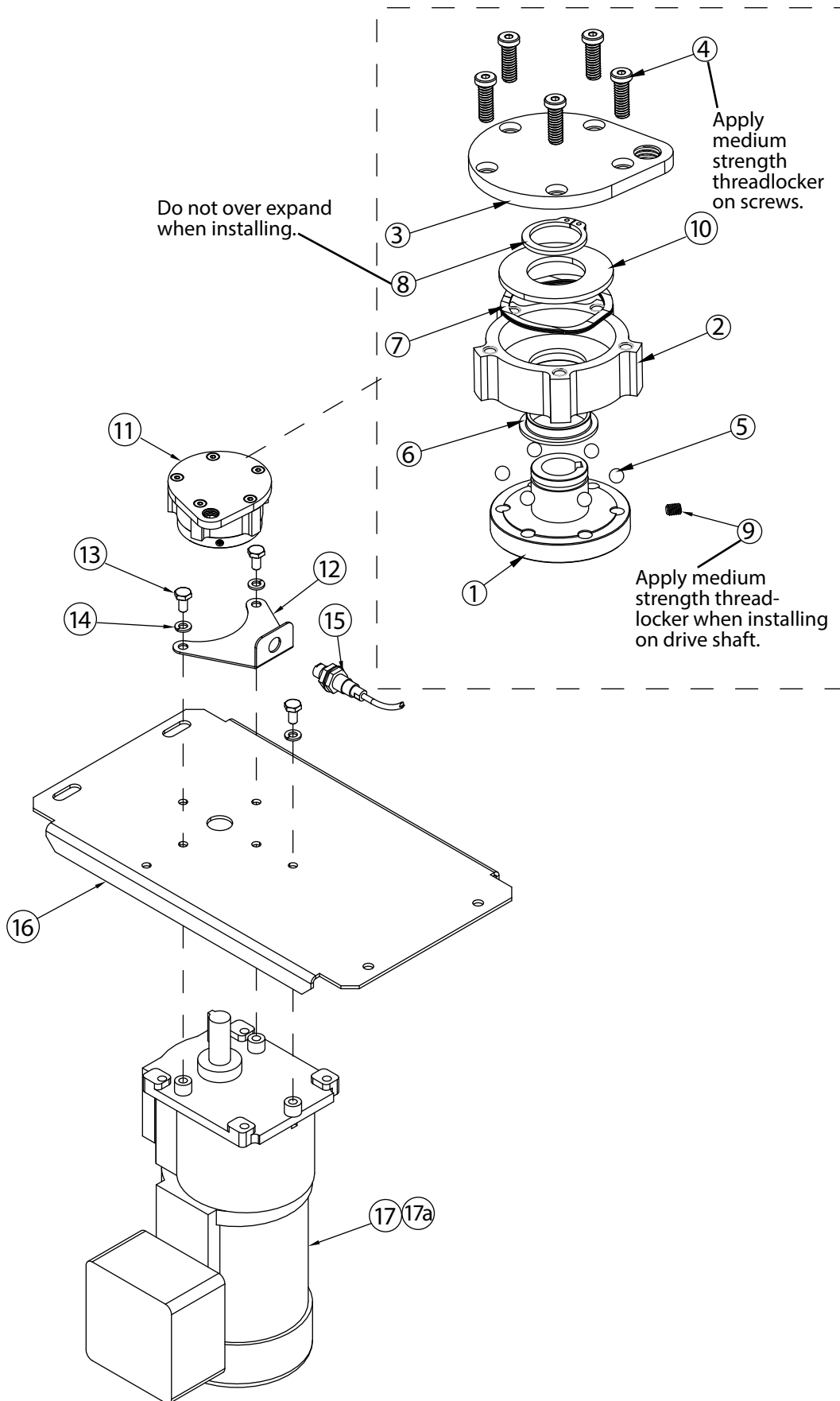

## Clutch Style Continual Drive Assembly

Item No.	Part No.	Description	Qty.
1	117044	DRIVE CLUTCH, LOWER HUB	1
2	117045	DRIVE CLUTCH, OUTER HUB	1
3	117046	CLUTCH LINKAGE	1
4	117050	LOW PROFILE BOLT, 1/4-20	5
5	117051	.250" STAINLESS STEEL BALL	6
6	117052	GFI-1618-04 IGUS BEARING	1
7	117109	SMALLEY WAVE SPRING	1
8	117110	HEAVY DUTY RETAINING SPRING	1
9	117111	10-32 SS NON-MARING SET SCREW	1
10	339623	PRO-DRIVE CLUTCH SPRING RETAINER	1
11	454231	PRO DRIVE CLUTCH	1
12	339377	DRIVE CLUTCH SENSOR BRACKET	1
13	100734	BOLT, HEX HEAD, 1/4-20 X 1/2" SST	3
14	106482	WASHER, LOCK, 1/4" SPLIT SST	3
15	117108	SENSOR, PROXIMITY	1
16	338708	BRACKET, CONTINUAL DRIVE MTR. SUPPORT	1
17	116810	GEARMOTOR, 1/6HP, MV/3PH, 27.2 RPM	A/R
17a	116908	GEARMOTOR, 1/6HP, 575/3PH, 27.2 RPM	A/R

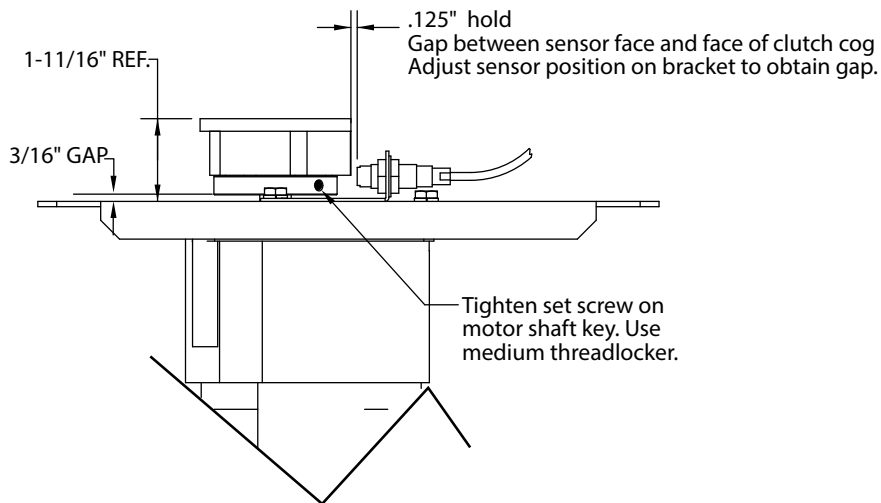

# Power Rinse Drain Assembly

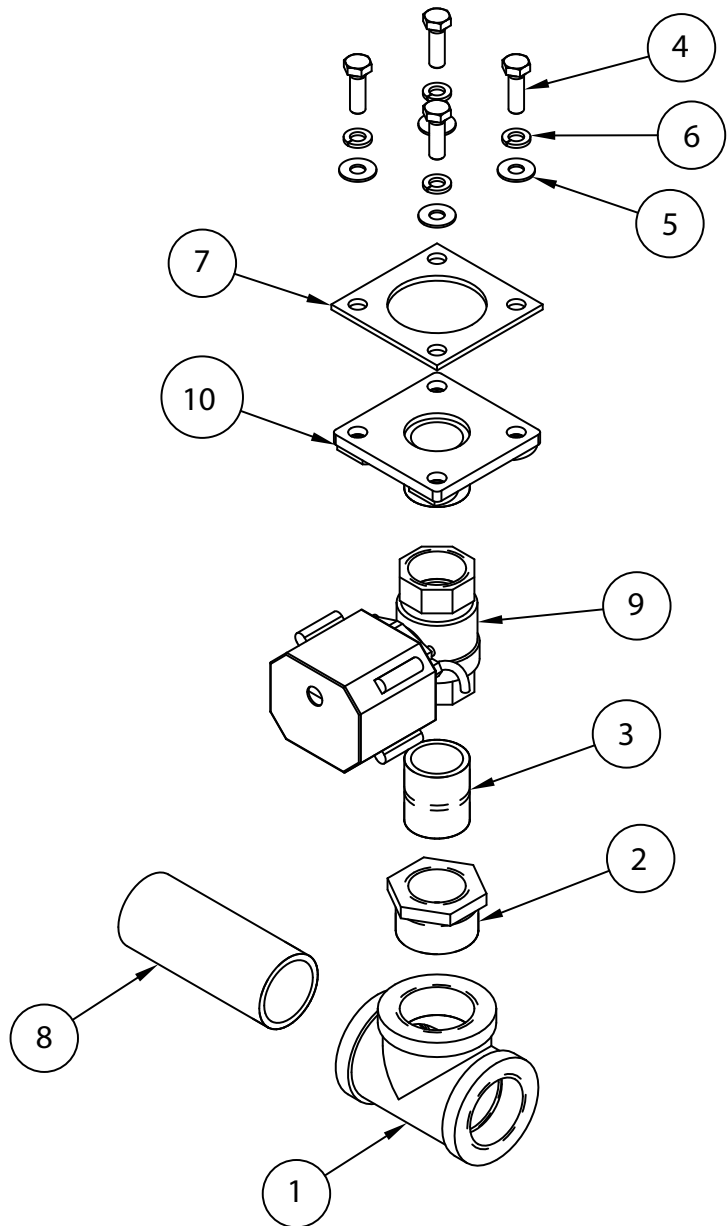

Item No.	Part No.	Description	Qty.
1	100510	TEE, 1-1/4" NPT SST	1
2	100535	BUSHING, REDUCING, 1-1/4" NPT X 1" NPT SST	1
3	100694	NIPPLE, 1" NPT X CLOSE SST	1
4	100740	BOLT HEX HEAD, 5-16/18 X 1" SST	4
5	102376	WASHER, FLAT 5/16" SST	4
6	106013	WASHER, LOCK 5/16" SPLIT SST	4
7	108345	GASKET 3" X 3" 1/8", 2" HOLE	1
8	115205	NIPPLE, TOE, 1-1/4" NPT X 4" LG. SST	1
9	117014	VALVE BALL, 1" NPT , BRASS, 110-230V ELECTRIC NC	1
10	339423	DRAIN FLANGE WELD, 1" MNPT, SST	1

# Wash Tank Drain Assy. without Prewash

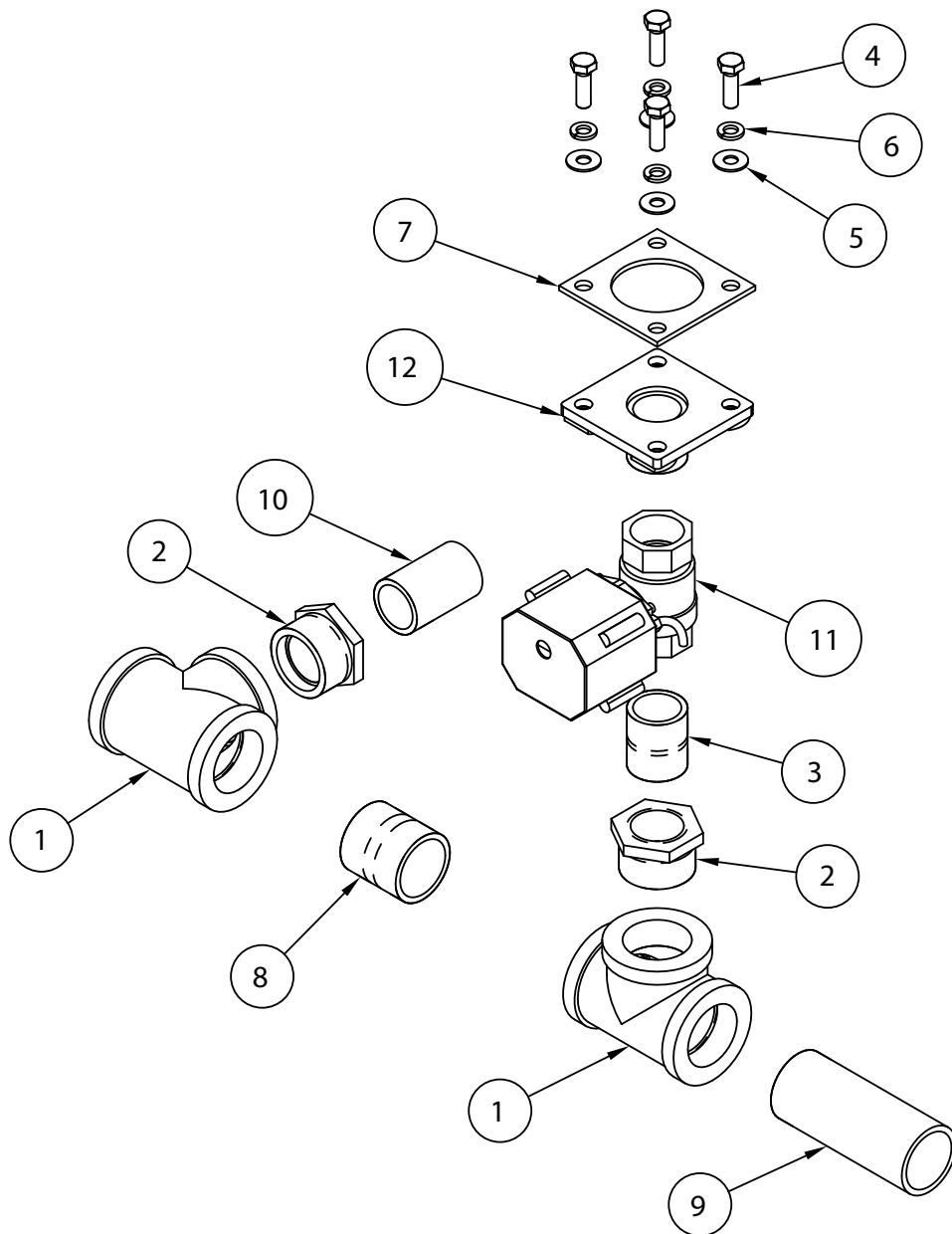

Wash Tank Drain Assy. without Prewash

Item No.	Part No.	Description	Qty.
1	100510	TEE, 1-1/4" NPT SST	2
2	100535	BUSHING, REDUCING, 1-1/4" NPT X 1" NPT SST	2
3	100694	NIPPLE, 1" NPT X CLOSE SST	1
4	100740	BOLT HEX HEAD, 5/16-18 X 1" SST	4
5	102376	WASHER, FLAT 5/16" SST	4
6	106013	WASHER, LOCK, 5/16" SPLIT SST	4
7	108345	GASKET, 3" X 3" X 1/8" 2" HOLE	1
8	111971	NIPPLE, 1-1/4" NPT X CLOSE, SST	1
9	115205	NIPPLE, TOE, 1-1/4"NPT X 4" LG. SST	1
10	116431	NIPPLE, TOE, 1" NPT X 2" LG. SST	1
11	117014	VALVE BALL, 1" NPT, BRASS 110-230V ELECTRIC NC	1
12	339423	DRAIN, FLANGE WELD, 1" MNPT, SST	1

Wash Tank Drain Assy. with Prewash

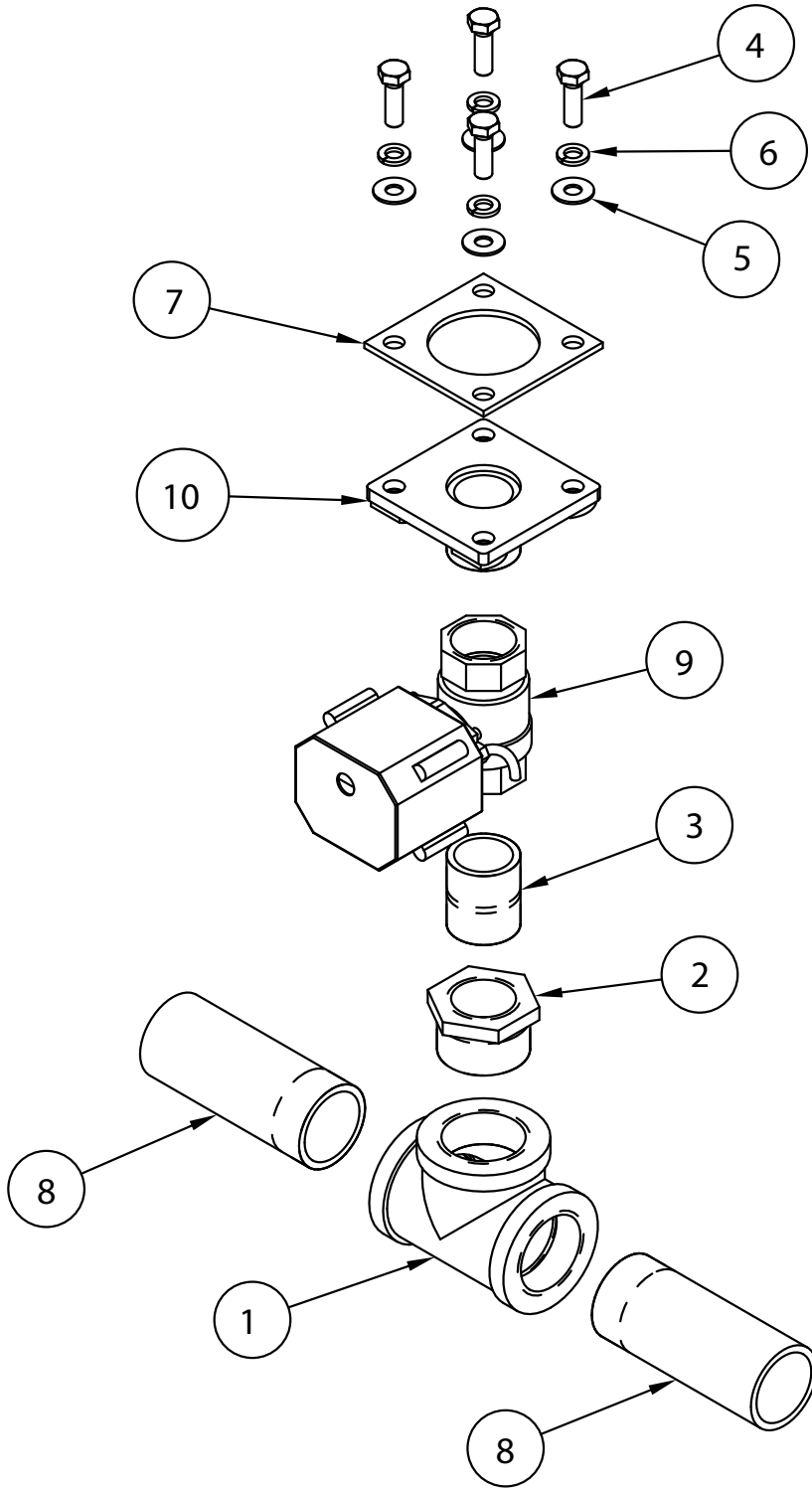



## Wash Tank Drain Assy. with Prewash

Item No.	Part No.	Description	Qty.
1	100510	TEE, 1-1/4" NPT SST	1
2	100535	BUSHING, REDUCING, 1-1/4" NPT X 1" NPT SST	1
3	100694	NIPPLE, 1" NPT X CLOSE SST	1
4	100740	BOLT HEX HEAD, 5/16-18 X 1" SST	4
5	102376	WASHER, FLAT 5/16" SST	4
6	106013	WASHER, LOCK, 5/16" SPLIT SST	4
7	108345	GASKET, 3" X 3" X 1/8" 2" HOLE	1
8	115205	NIPPLE, TOE, 1-1/4" NPT X 4" LG. SST	2
9	117014	VALVE, BALL 1" NPT BRASS, 110-230V ELECTRIC NC	1
10	339423	DRAIN, FLANGE WELD, 1" MPT, SST	1

# Fill Hoses

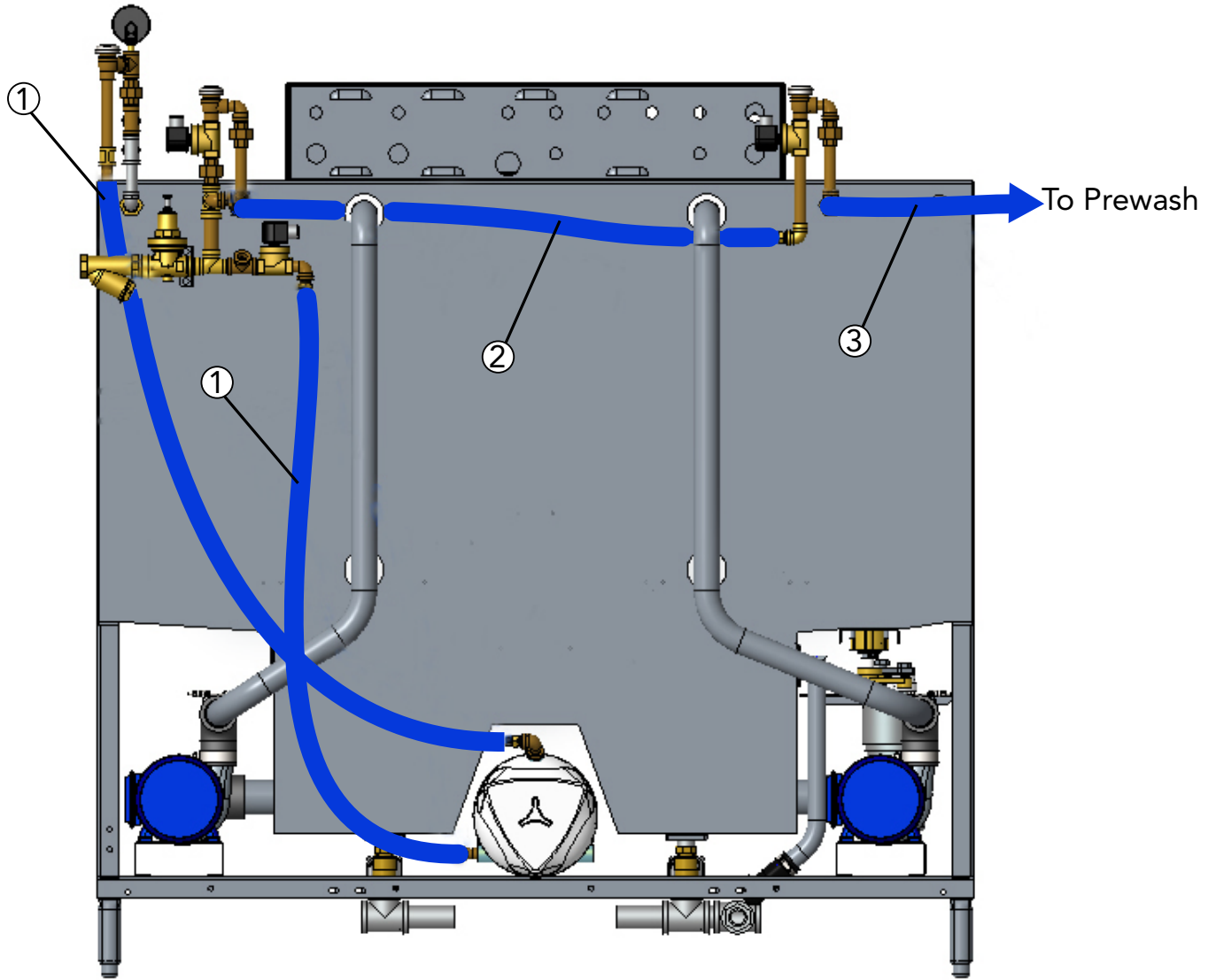

Item No.	Part No.	Description	Qty.
1	419012	HOSE ASSY., 1/2"ID, X 60" LG., FLARE JIC	2
2	421091	HOSE ASSY., 1/2"ID, X 39" LG., FLARE JIC	1
3	419228	HOSE ASSY., 1/2" ID, X 12" LG., FLARE JIC	1

# Power Rinse Fill Assembly

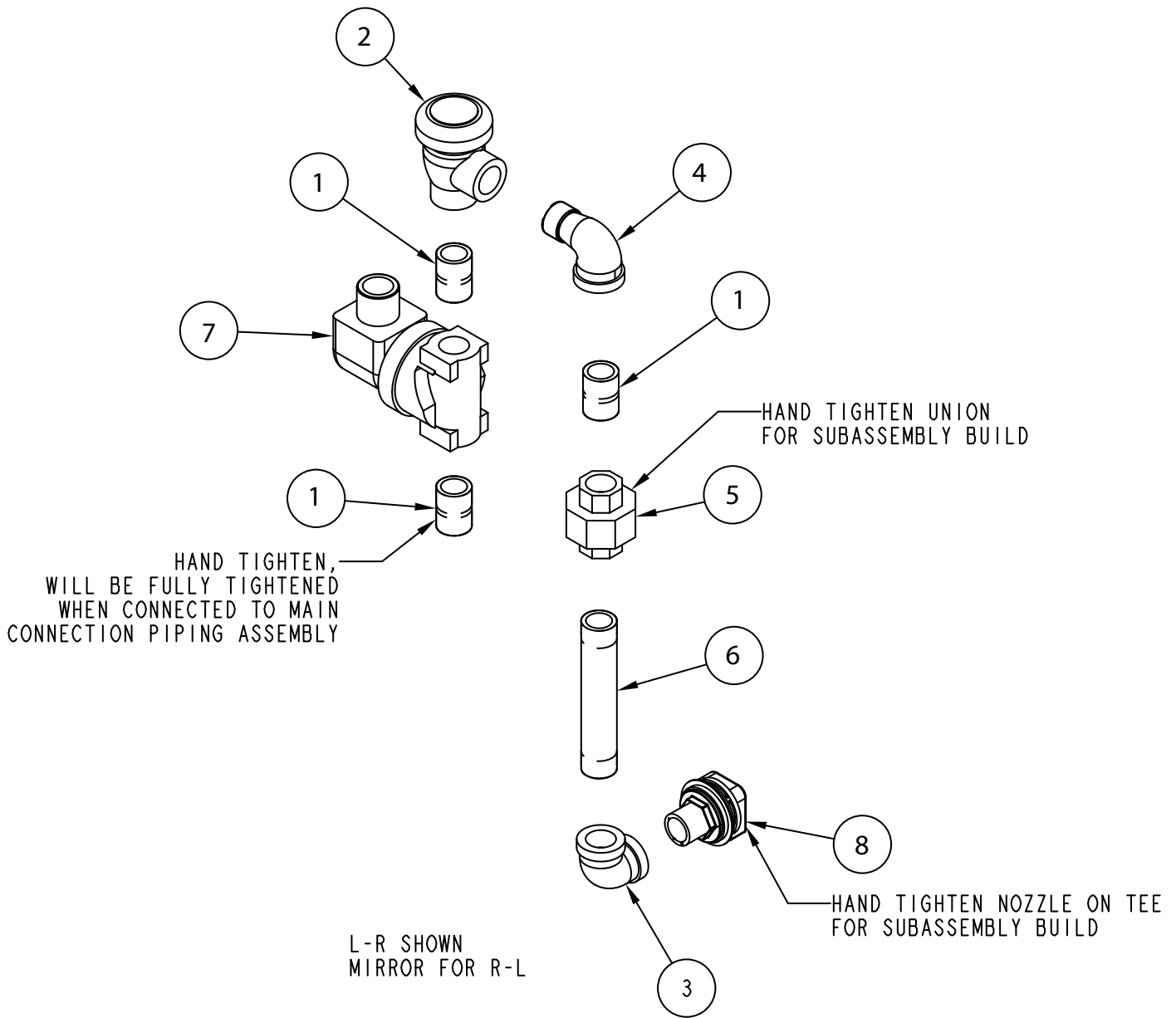

Item No.	Part No.	Description	Qty.
1	100209	NIPPLE, 1/2" NPT X CLOSE, BRASS	3
2	100500	VACUUM BREAKER, 1/2" NPT BRONZE	1
2a	900836	KIT, REPAIR VACUUM BREAKER, 1/2"	A/R
3	102435	ELBOW, 1/2" NPT X 90°, BRASS	1
4	102438	ELBOW, STREET, 1/2" NPT X 90°, BRASS	1
5	102549	UNION, 1/2" NPT, BRASS	1
6	102571	NIPPLE, 1/2" NPT X 4-1/4" LG., BRASS	1
7	109886	VALVE, SOLENOID, 1/2" NPT, HW PARKER	1
7a	109902	KIT, REPAIR VALVE, 1/2"	A/R
7b	108516	COIL, SOLENOID VALVE 120VAC	A/R
8	111325	NOZZLE, FLUSH-N POLISHED CHROME	1
---	602475	POWER RINSE FILL PIPING ASSY. COMPLETE (Includes Items 1-8)	A/R

# Wash Fill Assembly

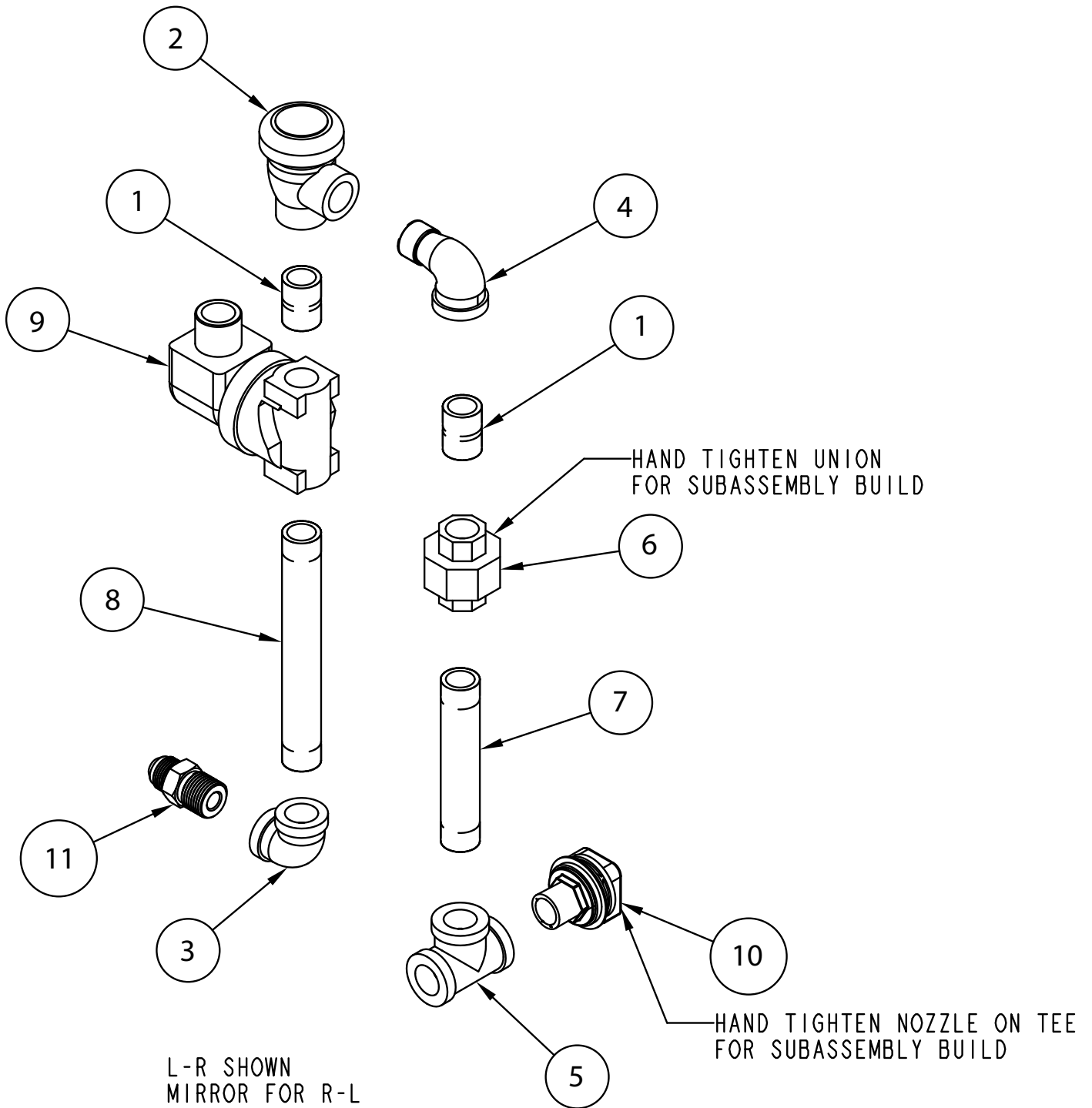

Item No.	Part No.	Description	Qty.
1	100209	NIPPLE, 1/2" NPT X CLOSE, BRASS	2
2	100500	VACUUM BREAKER, 1/2" NPT BRONZE	1
2a	900836	KIT, REPAIR VACUUM BREAKER, 1/2"	A/R
3	102435	ELBOW, 1/2" NPT X 90°, BRASS	1
4	102438	ELBOW, STREET, 1/2" NPT X 90°, BRASS	1
5	102514	TEE, 1/2" NPT, BRASS	1
6	102549	UNION, 1/2" NPT BRASS	1
7	102571	NIPPLE, 1/2" NPT X 4-1/4" LG., BRASS	1
8	102578	NIPPLE, 1/2" NPT X 6" LG., BRASS	1
9	109886	VALVE, SOLENOID, 1/2" NPT, HW PARKER	1
9a	109902	KIT, REPAIR VALVE, 1/2"	A/R
9b	108516	COIL, SOLENOID VALVE 120VAC	A/R
10	111325	NOZZLE, FLUSH-N POLISHED CHROME	1
11	115101	CONNECTOR, MALE, 1/2" NPT X 1/2" 37D FLARE JIC BRASS	1
---	602474	WASH FILL PIPING ASSY. COMPLETE (Includes Items 1-11)	A/R

# L-R Final Rinse Assembly

Parts breakdown on next page

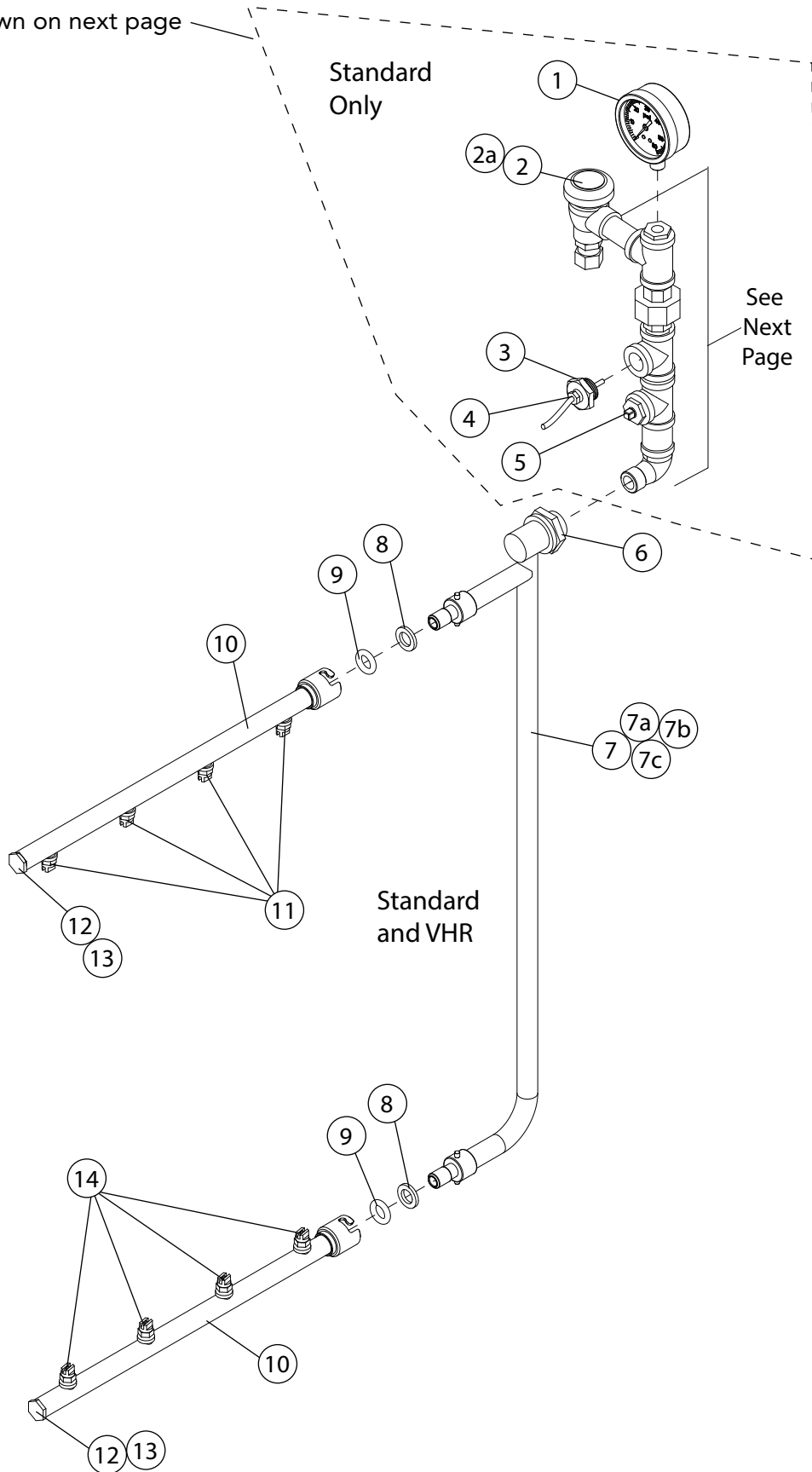

See Next Page



Item No.	Part No.	Description	Qty.
1	100135	GAUGE, PRESSURE, 0-60 PSI	1
2	100500	BREAKER, VACUUM 1/2" NPT BRONZE	1
2A	900836	KIT, REPAIR, VACUUM BREAKER 1/2"	A/R
3	0512299	ADAPTER	1
4	114435	THERMISTOR, 10K $\Omega$ , 36" LEAD	1
5	101259	PLUG, 1/8" NPT, SQ. HEAD, BRASS	1
6	100156	LOCKNUT, 3/4" NPT BRASS	1
7	338340	MANIFOLD, STANDARD FINAL RINSE, LR	1
7a	338341	MANIFOLD, STANDARD FINAL RINSE, RL	1
7b	338342	MANIFOLD, HIGH HOOD FINAL RINSE, LR	1
7c	338343	MANIFOLD, HIGH HOOD FINAL RINSE, RL	1
8	114291	WASHER, SILICONE	2
9	114290	O-RING	2
10	337056	ARM, FINAL RINSE	2
11	111938	NOZZLE, FINAL RINSE 8004	4
12	113795	PLUG, RINSE ARM	2
13	113716	O-RING	2
14	114181	NOZZLE, FINAL RINSE 8002	4

# L-R Final Rinse Piping Assembly

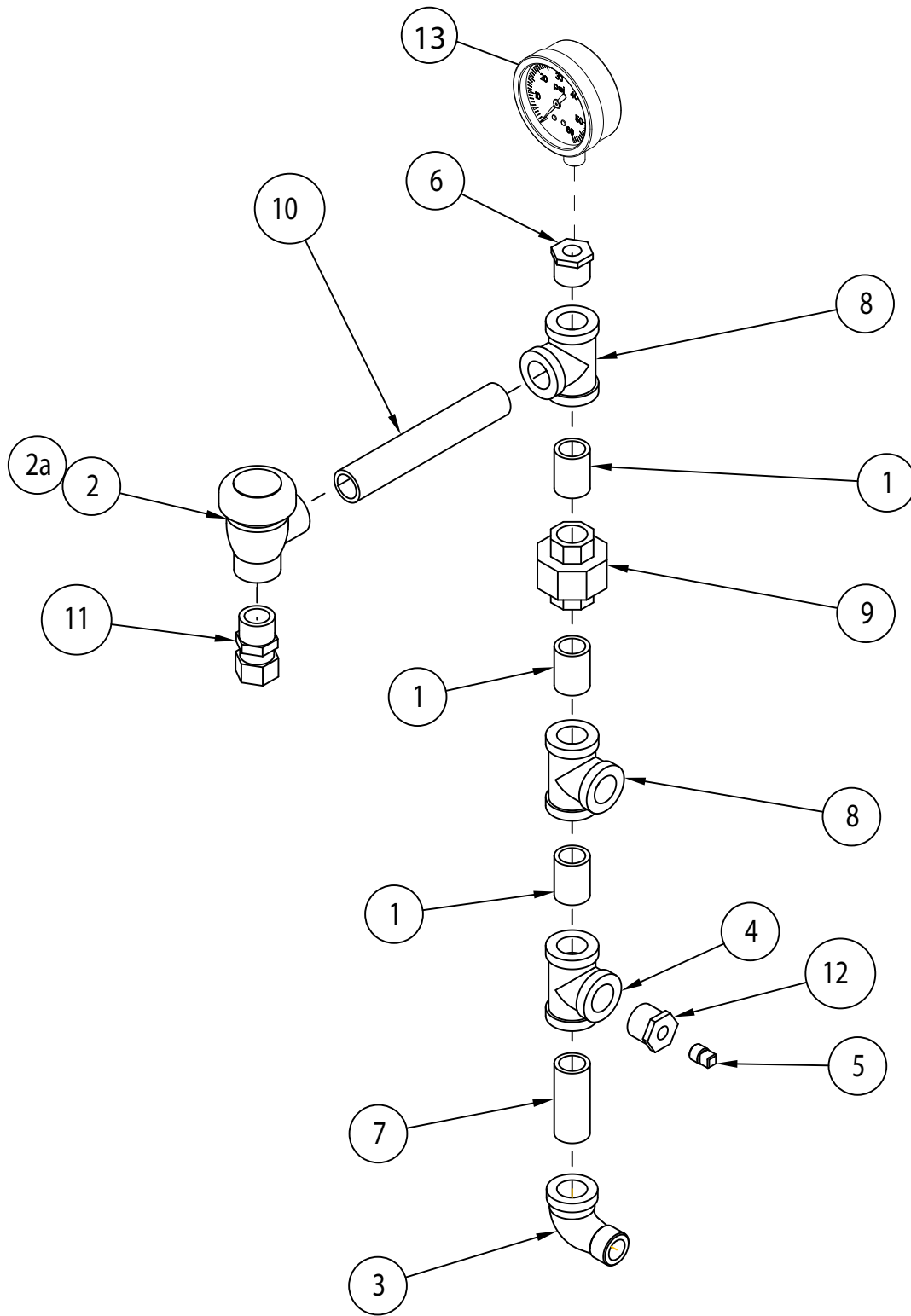

Item No.	Part No.	Description	Qty.
1	100209	NIPPLE, 1/2" NPT X CLOSE, BRASS	3
2	100500	BREAKER, VACUUM 1/2" NPT BRONZE	1
2a	900836	KIT, VACUUM BREAKER 1/2"	A/R
3	100516	ELBOW, STREET, 1/2" NPT X 90° SST	1
4	100554	TEE, 1/2" NPT SST	1
5	101259	PLUG, 1/8" NPT SQ. HEAD BRASS	1
6	102388	BUSHING, REDUCING 1/2" NPT X 1/4" NPT BRASS	1
7	102461	NIPPLE, 1/2" NPT X 2" LG. SST	1
8	102514	TEE, 1/2" NPT BRASS	2
9	102549	UNION, 1/2" NPT BRASS	1
10	102574	NIPPLE, 1/2" NPT X 5" LG. BRASS	1
11	109925	FITTING, COMPRESSION 5/8" OD X 1/2" MPT BRASS	1
12	114717	BUSHING, REDUCING 1/2" NPT X 1/8" NPT SST	1
13	100135	GAUGE, PRESSURE, 0-60 PSI	1
---	602435-LR	PIPING ASSY., FINAL RINSE, PRO L-R (Includes Items 1-13)	1
---	602435-RL	PIPING ASSY., FINAL RINSE, PRO R-L (Includes Items 1-13)	1

# L-R Main Connect Piping Assembly

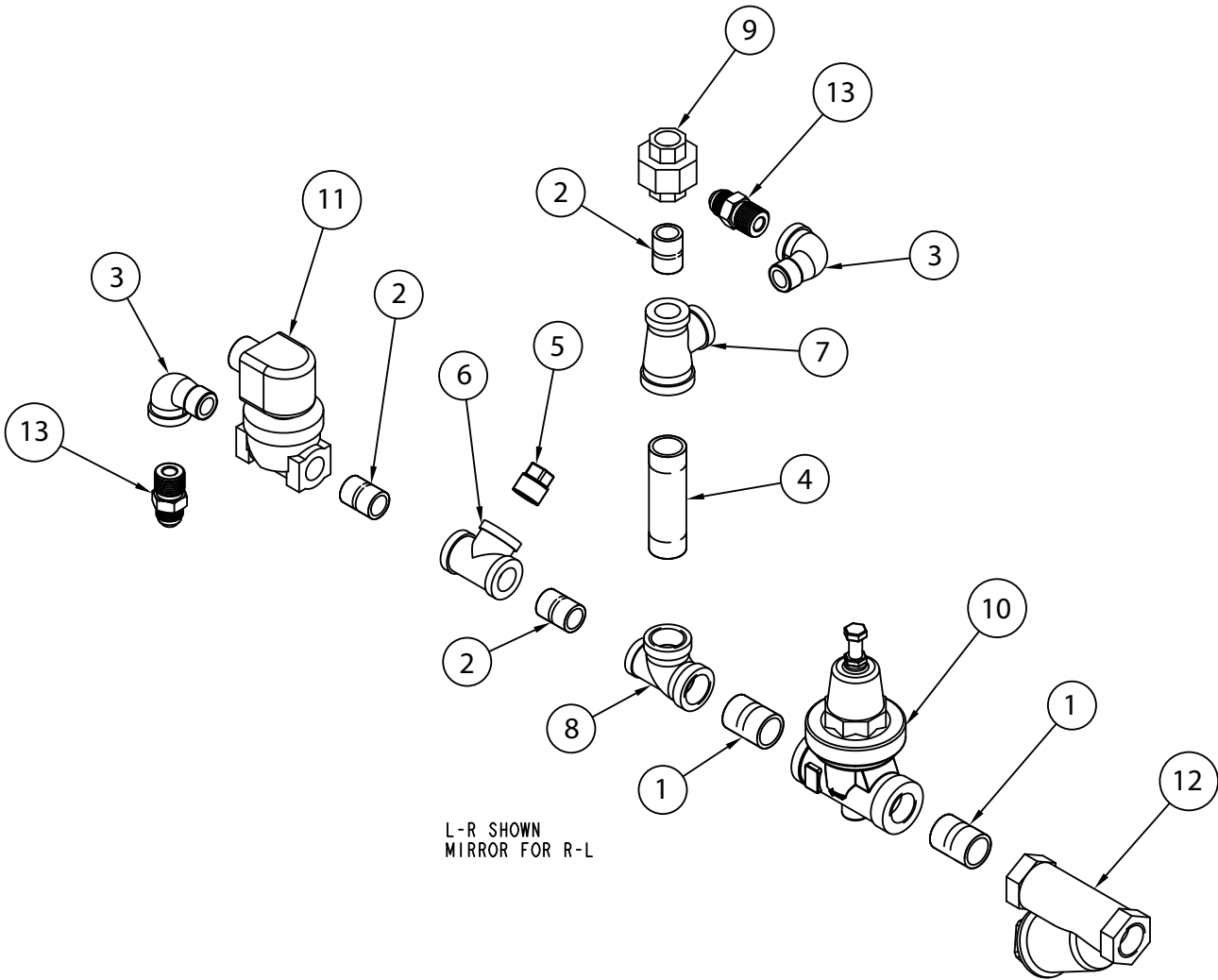

## L-R Main Connect Piping Assembly

Item No.	Part No.	Description	Qty.
1	100184	NIPPLE, 3/4" NPT X CLOSE, BRASS	2
2	100209	NIPPLE, 1/2" NPT X CLOSE, BRASS	3
3	102438	ELBOW, STREET , 1/2" NPT 90° BRASS	2
4	102490	NIPPLE, 3/4" NPT X 3-1/2" LG., BRASS	1
5	102504	PLUG, 1/2" NPT SQ. HEAD, BRASS	1
6	102514	TEE, 1/2" NPT, BRASS	1
7	102524	TEE, RED, 3/4" NPT X 1/2" NPT X 1/2" NPT, BRASS	1
8	102525	TEE, RED, 3/4" NPT X 1/2" NPT X 3/4" NPT BRASS	1
9	102549	UNION, 1/2" NPT BRASS	1
10	107550	VALVE, PRESSURE REDUCING, 3/4" NPT BRONZE	1
11	109886	VALVE, SOLENOID, 1/2" NPT, HW, PARKER	1
11a	109902	KIT, REPAIR VALVE, 1/2"	A/R
11b	108516	COIL, SOLENOID VALVE 120VAC	A/R
12	110768	STRAINER, LINE, 3/4" NPT BRASS	1
13	115101	CONNECTOR, MALE, 1/2" NPT X 1/2" 37D FLARE JIC BRASS	2
---	602461	MAIN CONNECT PIPING ASSY., L-R (Includes Items 1-13)	A/R

# 22" Prewash Door Assembly

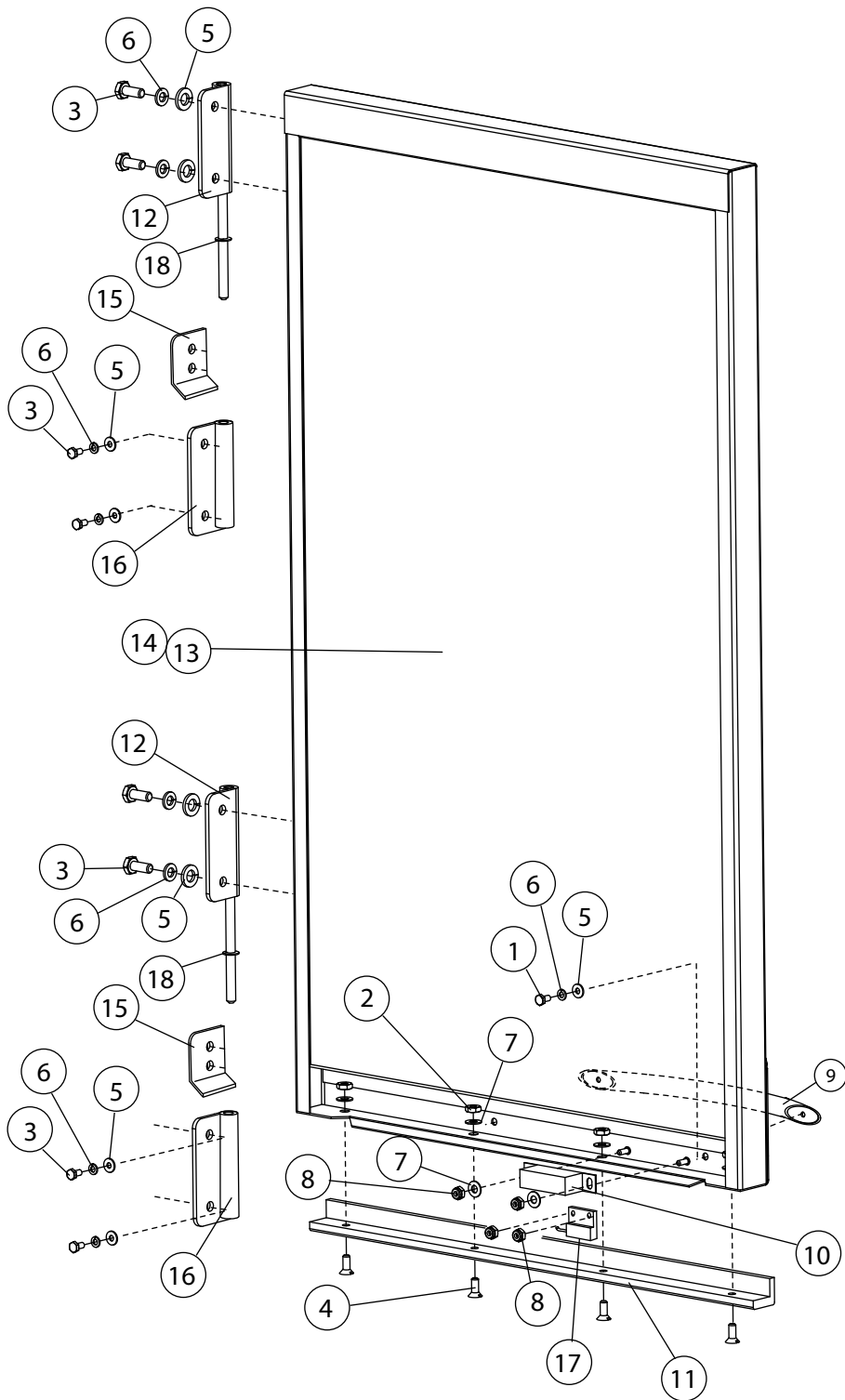

## 22" Prewash Door Assembly

Item No.	Part No.	Description	Qty.
1	100734	BOLT, HEX HEAD, 1/4-20 X 1/2" SST	2
2	100194	NUT, HEX GRIP 10-32 SST	4
3	100734	BOLT, HEX HEAD 1/4-20 X 1/2" SST	4
4	100754	SCREW, FLAT HEAD 10-32 X 1/2" SST	4
5	106026	WASHER, FLAT 1/4" SST	2
6	106482	WASHER, LOCK 1/4" SPLIT SST	6
7	107033	WASHER, FLAT SST	6
8	108954	NUT, GRIP 6-32 SST W/NYLON INSERT	2
9	115665	HANDLE, DOOR	1
10	113937	MAGNET, REED SWITCH	1
11	116175	STRIP, WEAR BOTTOM DOOR, E22 PREWASH	1
12	335152	HINGE, DOOR WELDMENT, RH	2
13	337199	DOOR, 22" HINGED STANDARD HOOD	1
14	338042	DOOR, 22", HINGED HIGH HOOD	1
15	335977	STOP, HINGED DOOR REMOVAL	2
16	335154	HINGE, DOOR HOOD	2
17	113721	SWITCH, REED, DOOR SAFETY	1
18	116230	WASHER, FLAT	2

# 36" Prewash Door Assembly

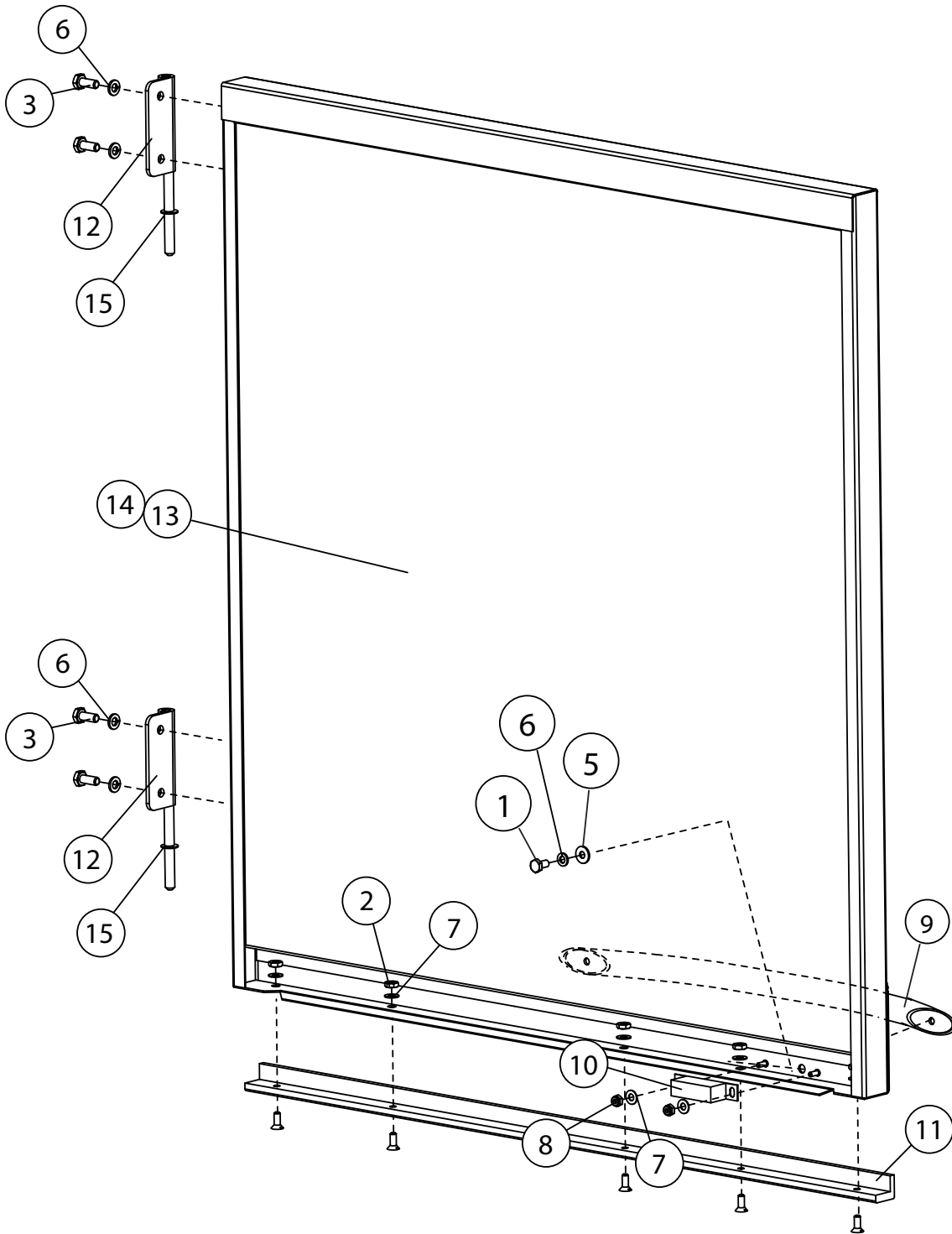



## 36" Prewash Door Assembly

Item No.	Part No.	Description	Qty.
1	100734	SCREW, TRUSS HEAD, 1/4-20 X 1/2" SST	6
2	100194	NUT, HEX GRIP 10-32 SST	12
3	100735	BOLT, HEX HEAD 1/4-20 X 5/8" SST	8
4	100754	SCREW, FLAT HEAD 10-32 X 1/2" SST	12
5	106026	WASHER, FLAT 1/4" SST	6
6	106482	WASHER, LOCK 1/4" SPLIT SST	6
7	107033	WASHER, FLAT 0.208" SST	7
8	108954	NUT, HEX GRIP 6-32 SST W/NYLON INSERT	2
9	115665	HANDLE, DOOR	1
10	113937	MAGNET, REED SWITCH	1
11	116177	STRIP, WEAR BOTTOM DOOR	1
12	335152	HINGE, DOOR	2
13	337865	DOOR, 36", RH, STANDARD HOOD	1
14	339642	DOOR 36", RH HIGH-HOOD	1
15	116230	WASHER, FLATUHMW	2

# Wash Door Assembly

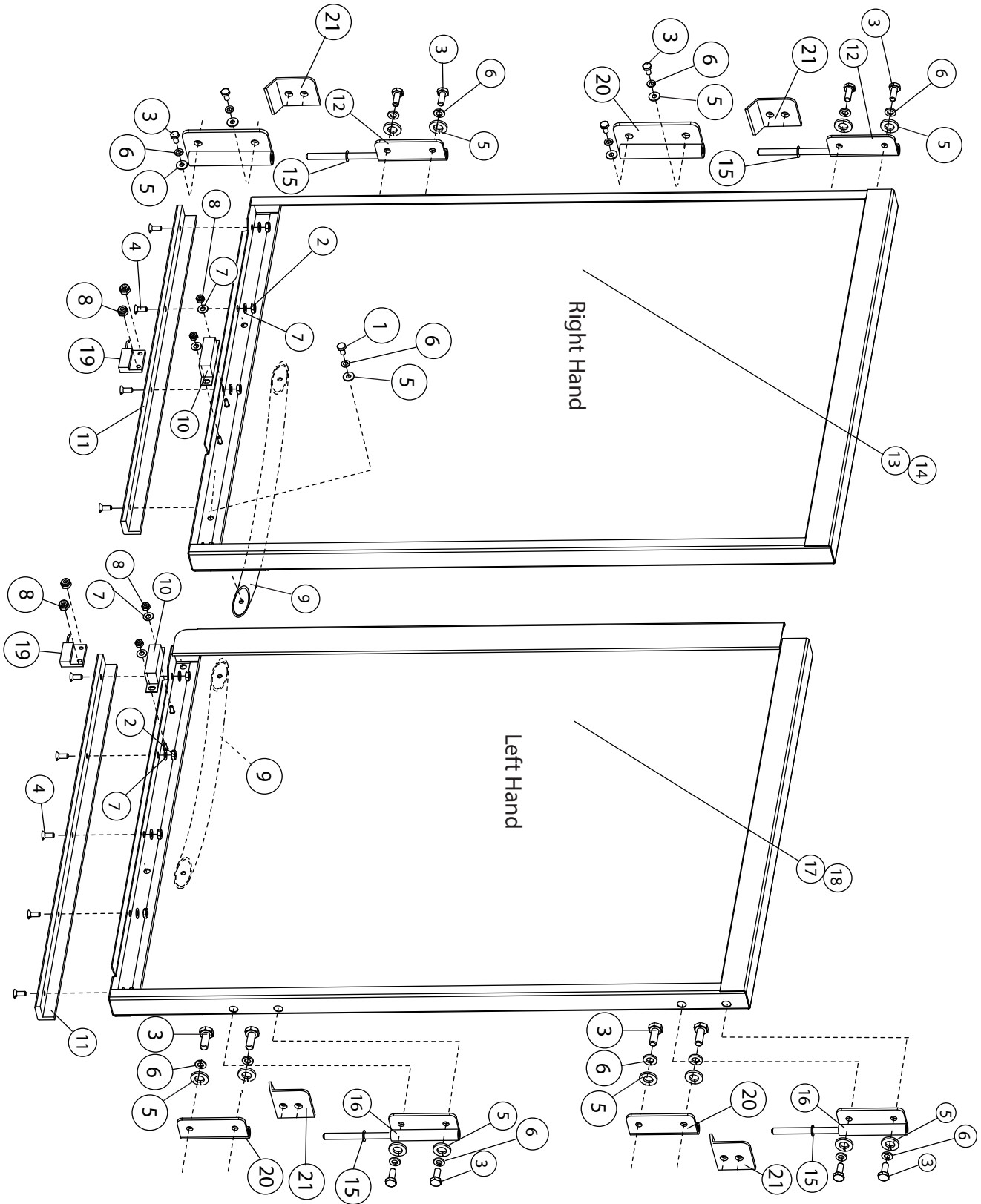

Item No.	Part No.	Description	Qty.
1	100734	BOLT, HEX HEAD, 1/4-20 X 1/2" SST	4
2	100194	NUT, GRIP 10-32 SST	9
3	100735	BOLT, HEX HEAD 1/4-20 X 5/8" SST	8
4	100754	SCREW, FLAT HEAD 10-32 X 1/2" SST	9
5	106026	WASHER, FLAT 1/4" SST	19
6	106482	WASHER, LOCK 1/4" SPLIT SST	19
7	107033	WASHER, FLAT SST	13
8	108954	NUT, GRIP 6-32 SST W/NYLON INSERT	8
9	115665	HANDLE, DOOR	2
10	113937	MAGNET, REED SWITCH	2
11	116177	STRIP, WEAR BOTTOM DOOR	2
12	335152	HINGE, RH DOOR WELDMENT	2
13	337865	DOOR, RH STANDARD HOOD	1
14	339642	DOOR, RH HIGH HOOD	1
15	116230	WASHER, UHMW	4
16	335151	HINGE, LH DOOR WELDMENT	2
17	338280	DOOR, LH HINGED, STANDARD HOOD	1
18	339641	DOOR, LH HINGED, HIGH HOOD	1
19	113721	SWITCH, REED DOOR SAFETY	1
20	335154	HINGE, HOOD SIDE	4
21	335977	STOP, HINGED DOOR REMOVAL	4

# Tank Panels and Curtains

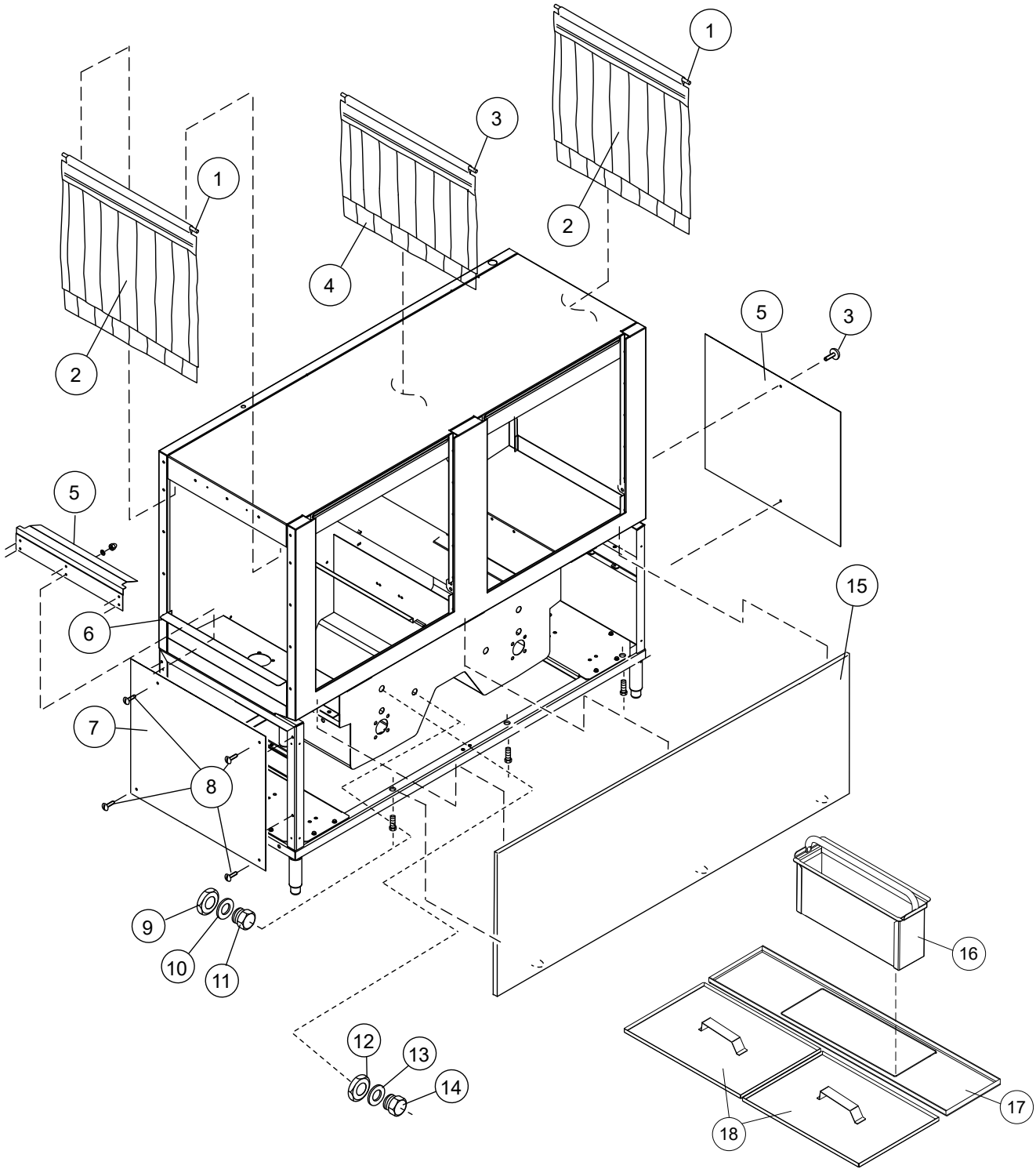

Item No.	Part No.	Description	Qty.
1	108250	ROD,CURTAIN, 5/16" X 24-5/8"	2
2	113720	CURTAIN, 24" X 20-1/4"	2
3	114012	ROD, CURTAIN, 5/16" X 23.63"	1
4	108043	CURTAIN, 24" X 13-1/4"	1
5	329927	BAFFLE, TABLE WITH CUTOUT	1
6	328451	FLANGE, TABLE	2
7	337085	PANEL, END, 25" STANDARD	1
8	100073	SCREW, 1/4-20 X 1/2" TRUSS HEAD	8
9	113944	NUT, 3/4" NPT PLASTIC	4
10	108620	GASKET, 3/4" PLUG	4
11	113943	PLUG, 3/4" NPT PLASTIC	4
12	108417	NUT, 1/2" NPT PLASTIC	4
13	109034	GASKET, 1/2" NPT PLUG, FIBER WASHER	4
14	108418	PLUG, 1/2" NPT PLASTIC	4
15	338350	PANEL, FRONT PERIMETER	1
16	338148	BASKET, REFUSE	2
17	338149	FILLER, SCRAP BASKET	2
18	339487	SCREEN, SCRAP	4

# Tank Floats and Thermistors

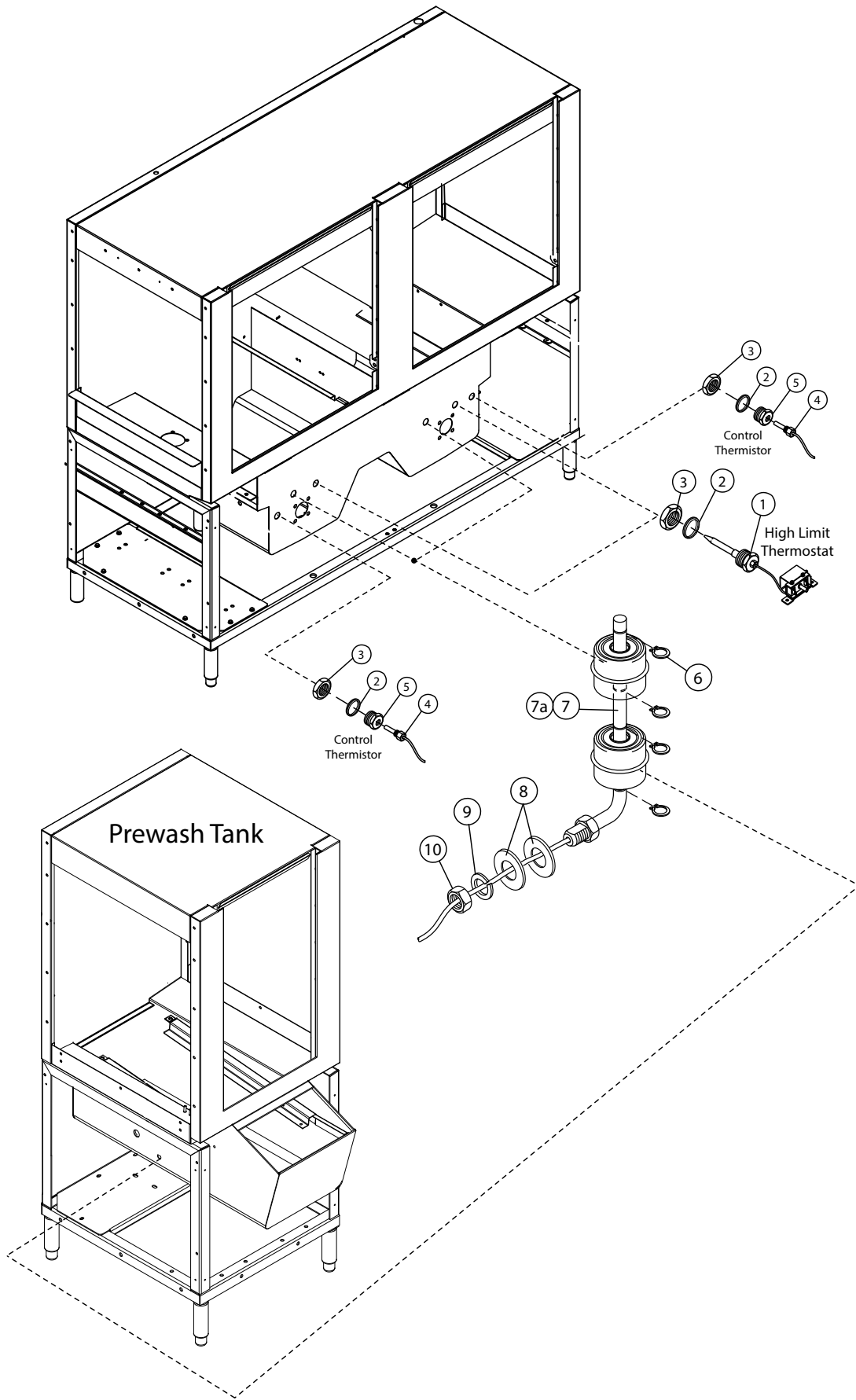

Item No.	Part No.	Description	Qty.
1	110561	THERMOSTAT, FIXED HIGH LIMIT, 240°F	2
2	115489	O-RING	2
3	100547	LOCKNUT, 1/2" NPT SST	2
4	114435	THERMISTOR, 10kΩ, 36" LEAD	4
5	0512299	ADAPTER	2
6	111151	C-CLIP	A/R
7	110854	FLOAT SWITCH, DUAL PREWASH	1
7a	113291	FLOAT SWITCH, DUAL WASH	2
8	104882	WASHER, FLAT 1/2" SST	6
9	107589	WASHER, LOCK 1/2" SST	3
10	104584	NUT, PLAIN 1/2-13	3
---	110750	GASKET, FLOAT SWITCH (NOT SHOWN)	3

Left-hand Wash Arm Assembly

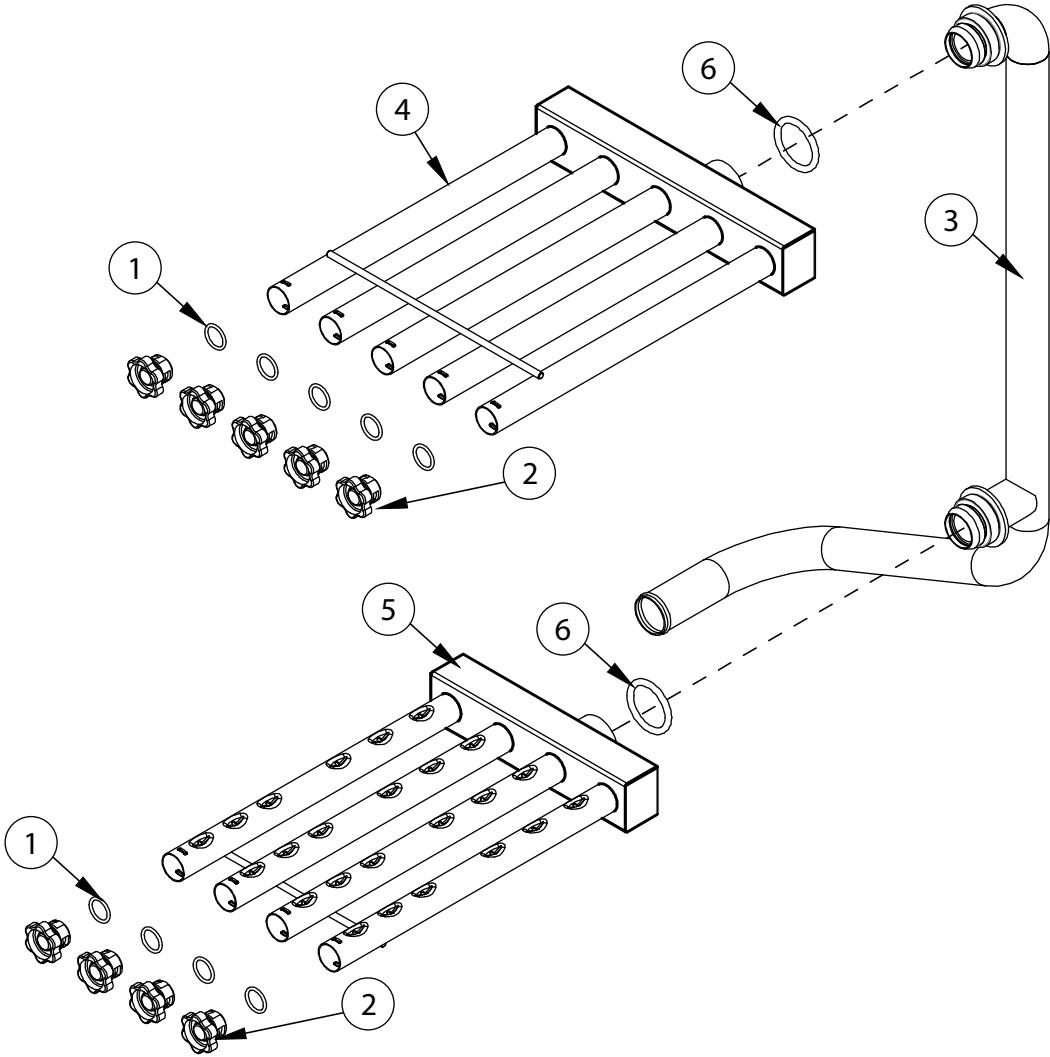



Left-hand Wash Arm Assembly

Item No.	Part No.	Description	Qty.
1	104414	O-RING, 1" X 1-1/4" X 1/8"	9
2	112240	PLUG, DEBOSSSED SPRAYPIPE	9
3	339125	STANDPIPE WELD., LH, 64PRO, STD. HT.	1
4	339130	MANIFOLD WELD., 64PRO, UPPER, LH 5-PIPE	1
5	339355	MANIFOLD WELD., 64PRO, LOWER, LH 4-PIPE	1
6	116609	O-RING, WASH ARM	2

# Right-hand Wash Arm Assembly

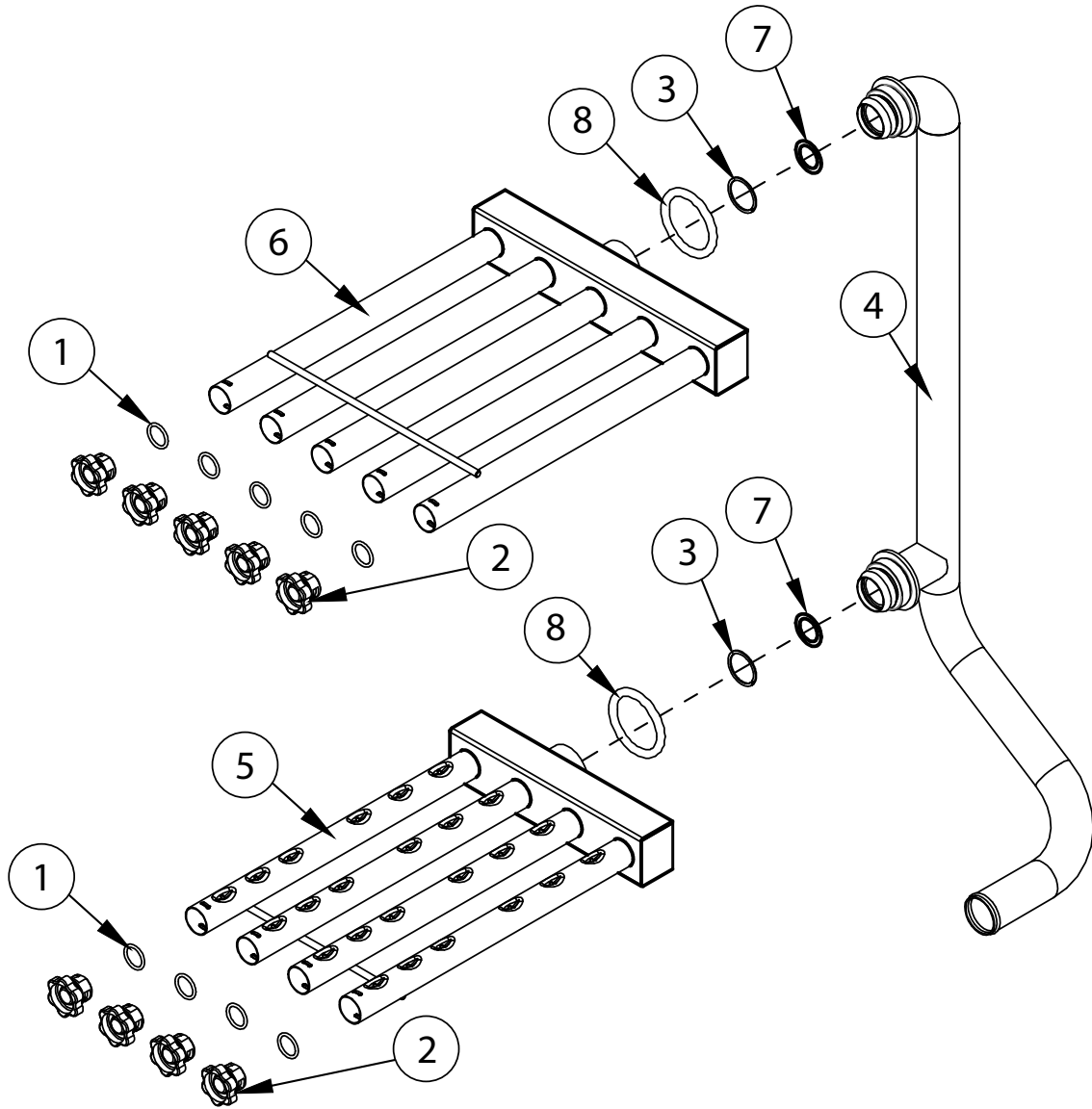

Item No.	Part No.	Description	Qty.
1	104414	O-RING, 1" X 1-1/4" X 1/8"	9
2	112240	PLUG, DEBOSSSED SPRAYPIPE	9
3*	117039	RETAINING RING, INTERNAL, 1-5/8" STD. HT.	2
4	339128	STANDPIPE WELD., RH, 64PRO, STD. HT.	1
5	339131	MANIFOLD WELD., 64PRO, LOWER, RH 4-PIPE	1
6	339132	MANIFOLD WELD., 64PRO, UPPER RH, 5-PIPE	1
7*	339485-1	RESTRICTOR, WASHER STYLE, PRO, 1.125"	2
8	116609	O-RING, WASH ARM	2

\* RETAINING RING AND RESTRICTOR GO INTO THE POWER RINSE ONLY.

# 22" and 36" Prewash Panels and Curtains

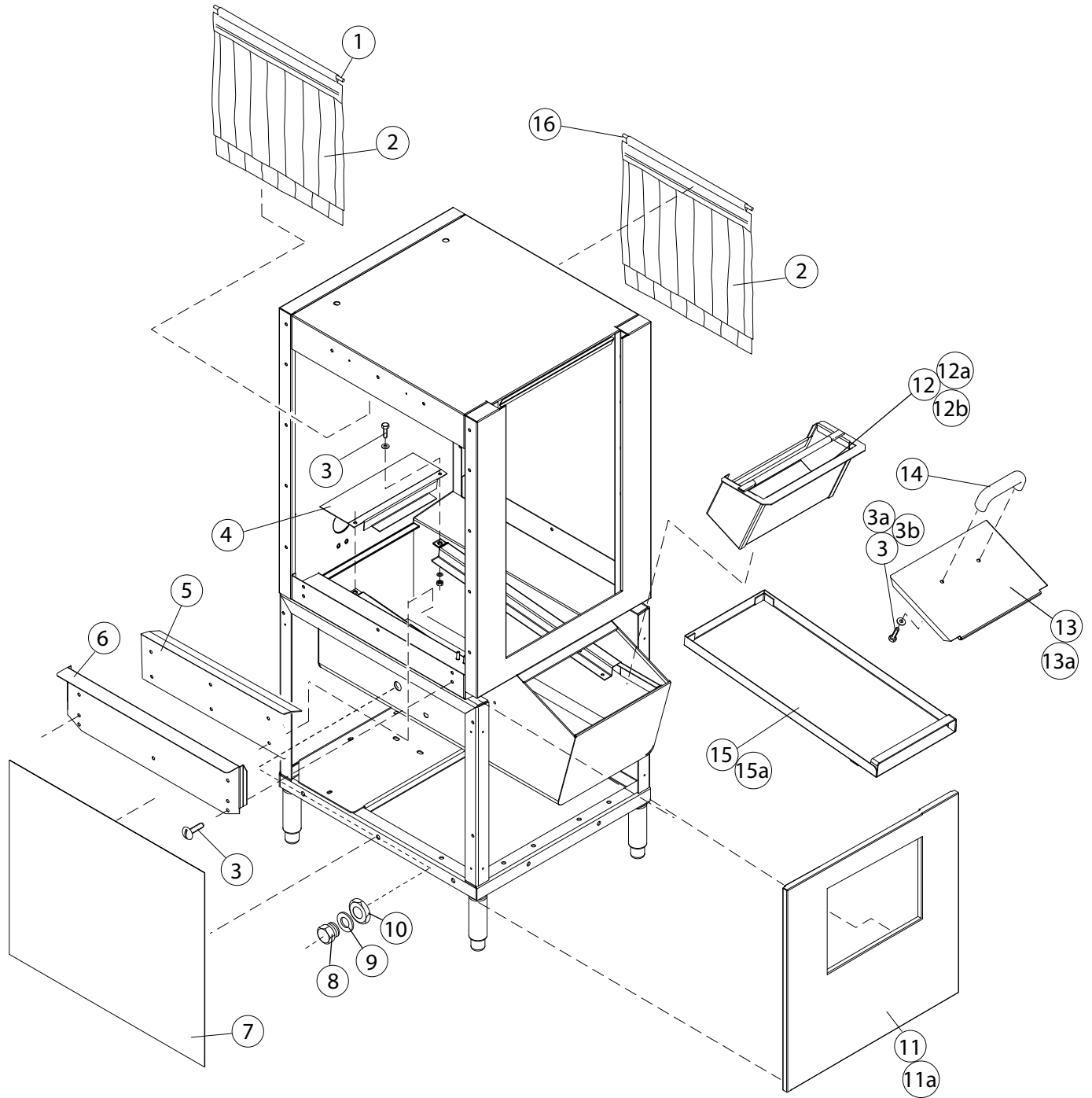

22" and 36" Prewash Panels and Curtains

Item No.	Part No.	Description	Qty.
1	108250	ROD CURTAIN 5/16 X 24-5/8"	1
2	113720	CURTAIN 24 X 20-1/4"	2
3	100735	BOLT, 1/4-20 X 5/8" HEX HEAD	8
3a	106482	WASHER, LOCK, 1/4" SPLIT	2
3b	106026	WASHER, 1/4" X 5/8"	2
4	328006	SUPPORT, 22" PW REAR SCREEN	1
5	329927	BAFFLE, TABLE FLANGE WITH CUTOUT	1
6	328030	TABLE FLANGE	1
7	337085	PANEL, 25" END STANDARD	1
8	108418	PLUG, 1/2" PLASTIC	2
9	109034	GASKET, 1/2" FIBER WASHER	2
10	108417	NUT, 1/2" NPT PLASTIC	2
11	337213	PANEL ASSY. FRONT PERIMETER 22" PW	1
11a	334756	PANEL ASSY. FRONT PERIMETER 26" PW	1
11b	337870	PANEL ASSY. FRONT PERIMETER 36" PW	1
12	328959	BASKET, REFUSE 22"	1
12a	329492	BASKET, REFUSE 26"	1
12b	328967	BASKET, REFUSE 36"	1
13	335332	COVER, REFUSE BASKET 22" PW	1
13a	335333	COVER, REFUSE BASKET 36" PW	1
14	108966	HANDLE, DOOR	1
15	328958	SCREEN, SCRAP, 22"	1
15a	328960	SCREEN, SCRAP 36" PW	2
16	114012	ROD, CURTAIN 5/16" X 23.63"	1
---	901090	KIT, 22PW REFUSE BASKET COVER KIT W/HANDLE (Includes Items 3, 3a, 3b, 13, 14)	1
---	901091	KIT, 36PW REFUSE BASKET COVER KIT W/HANDLE (Includes Items 3, 3a, 3b, 13A, 14)	1

# 22" and 36" Prewash Spray Arms

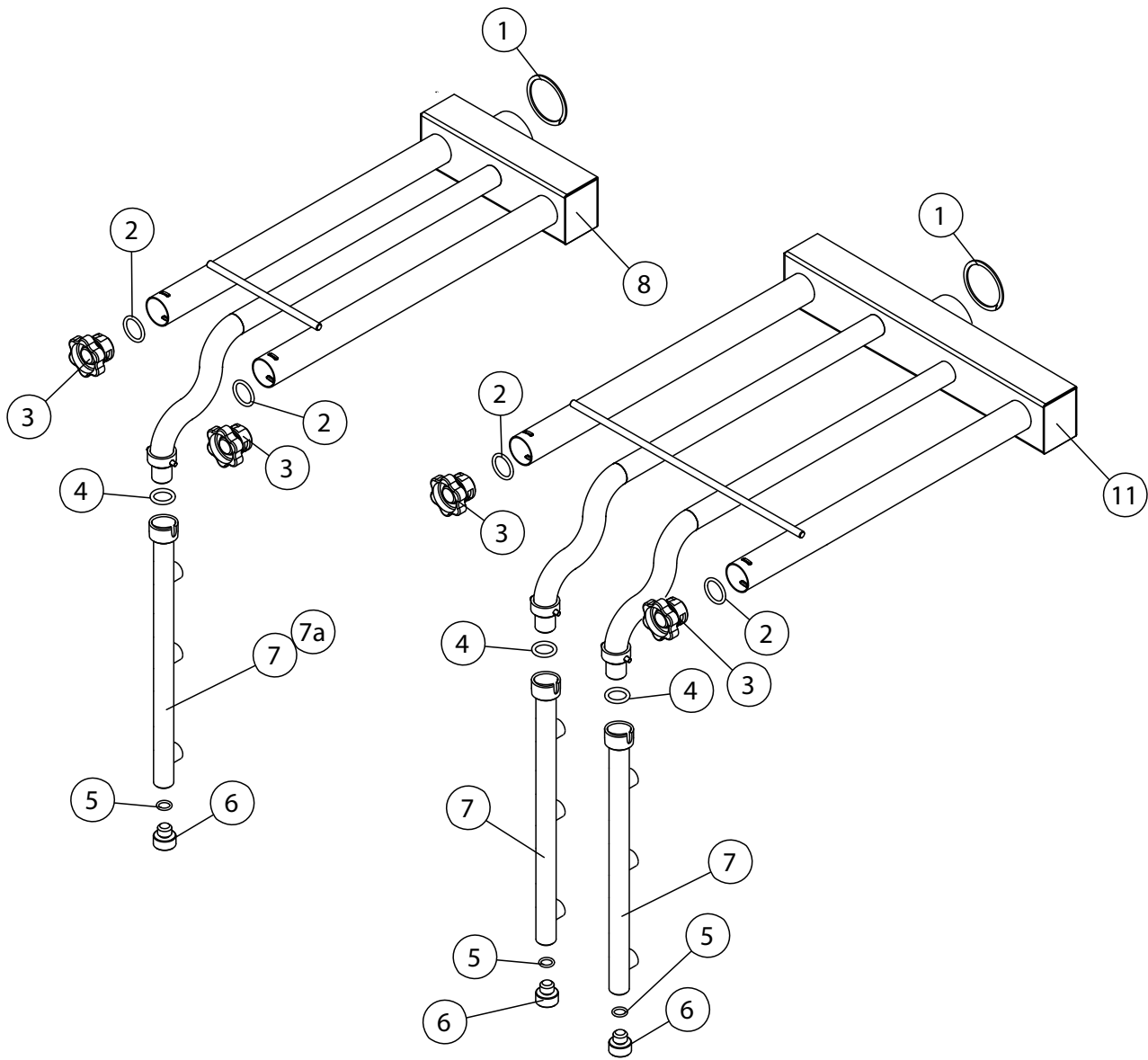

## 22" and 36" Prewash Spray Arms

Item No.	Part No.	Description	Qty.
1	116609	O-RING, WASH ARM	1
2	104414	O-RING, END CAP	A/R
3	112240	CAP, END WASH ARM	A/R
4	116608	O-RING, PREWASH SIDE ARM	A/R
5	113716	O-RING	A/R
6	113555	PLUG, CLEANOUT	A/R
7	337656	SPRAYPIPE, SIDEWASH 22/36PW, STD HEIGHT	A/R
7a	338214	SPRAYPIPE, SIDEWASH 22PW, HIGH HOOD	1
8	337665	WASH ARM MANIFOLD, PREWASH 22" RL	1
8a	337657	WASH ARM MANIFOLD, PREWASH 22" LR	1
11	337988	WASH ARM MANIFOLD, PREWASH 36PW (RL &LR)	1

# Wash/Power Rinse Heaters

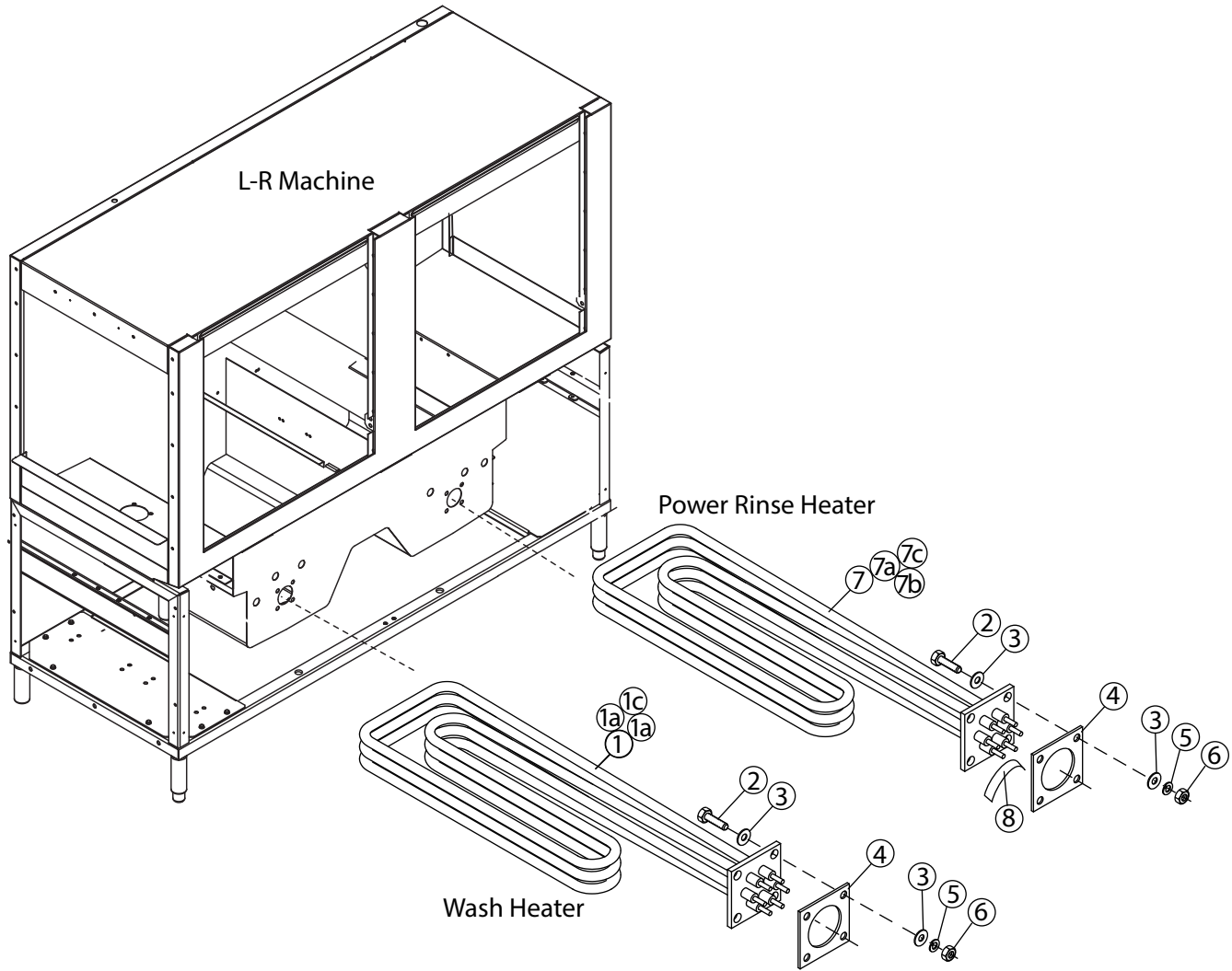



Item No.	Part No.	Description	Qty.
1	113516	HEATER, 15/18KW 200-220V/60/1 & 3, 380V/60/3	1
1a	113517	HEATER, 15/16/3 KW 230-240V/60/1 & 3 400-415V/60/3	1
1b	113518	HEATER, 15/16.3 KW 460-480V/60/3	1
1c	113519	HEATER, 15KW, 575V/60/3	1
2	100153	BOLT, 3/18-16 x 1" HEX HEAD, SST	4
3	104618	WASHER, FLAT 3/8" SST	8
4	108345	GASKET, 3" x 3" x 1/8", 2" HOLE	1
5	106407	WASHER, LOCK 3/8" SPLIT, SST	4
6	100140	NUT, PLAIN 3/8-16 SST	4
7	113804	HEATER, 10/12.1KW 200-220/3	1
7a	113882	HEATER, 10/11 KW 230-240V/3	1
7b	113883	HEATER, 10/11KW, 460-480V/3	1
7c	113884	HEATER, 10/11KW, 575V/3	1
8	111885	INSULATION, FISH PAPER	1

# Electric Booster

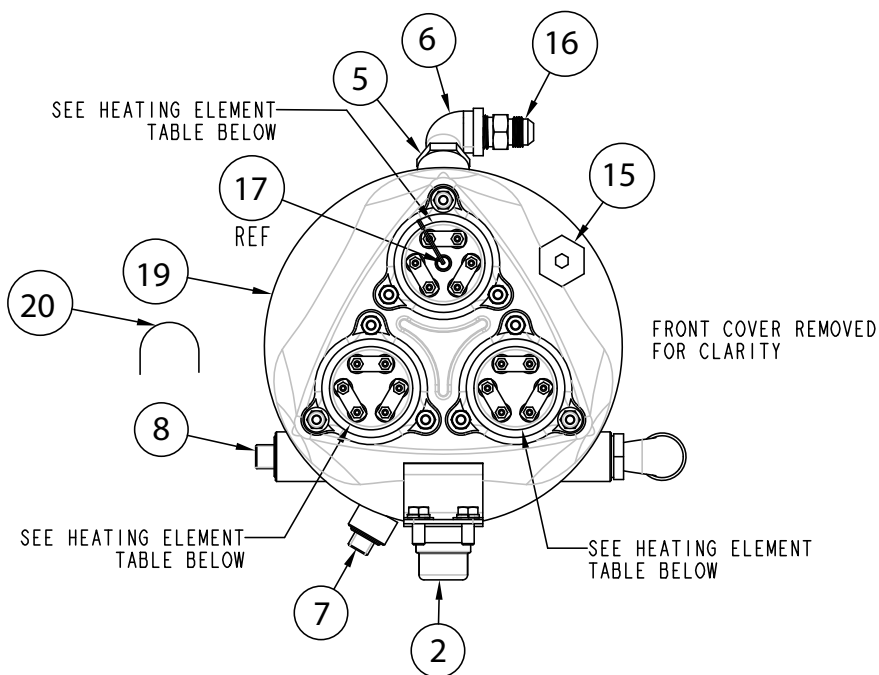
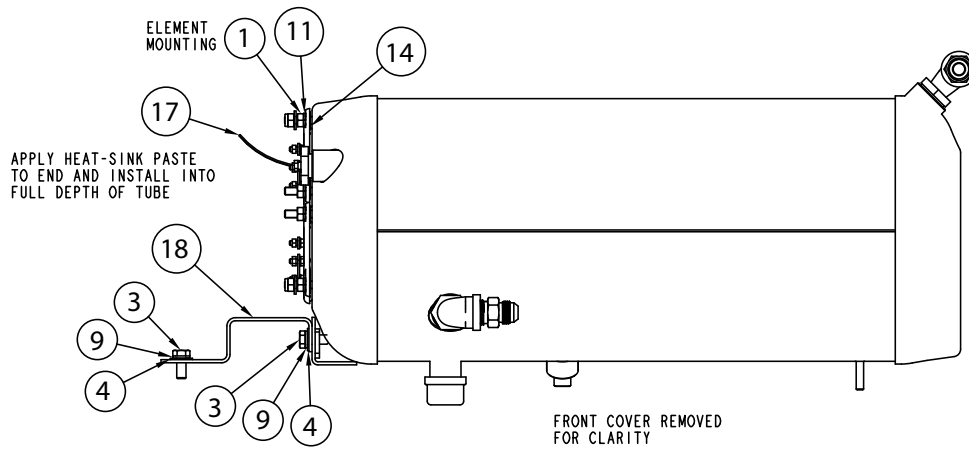
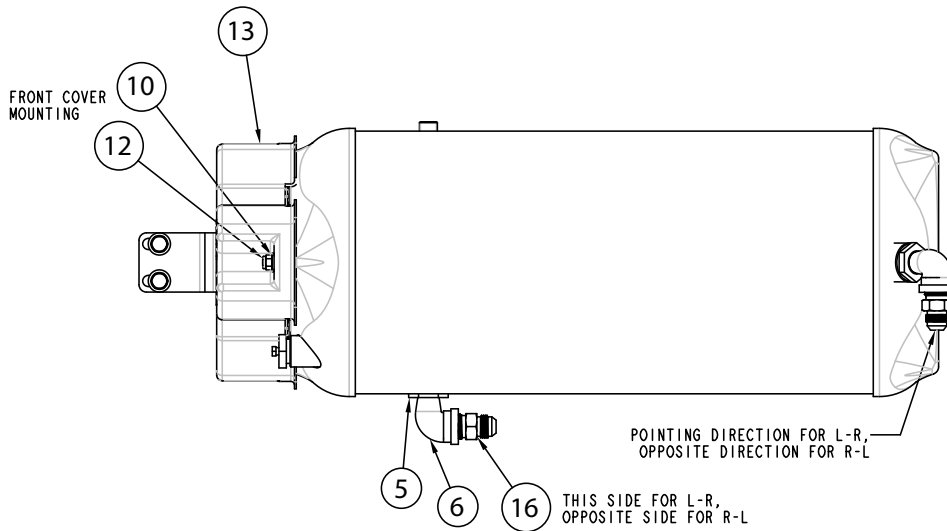

Item No.	Part No.	Description	Qty.
1	100003	NUT, PLAIN, 1/4-20 SST	9
2	100113	CAP, 3/4" NPT, SST	1
3	100739	BOLT, HEX HEAD, 5/16-18 X 3/4" SST	4
4	102376	WASHER, FLAT 5/16"	4
5	102392	BUSHING, REDUCING, 3/4" NPT X 1/2" NPT BRASS	2
6	102438	ELBOW, STREET, 1/2" NPT X 90°	2
7	102504	PLUG, 1/2" NPT, SQ. HD, BRASS	1
8	102505	PLUG, 3/4" NPT SQ. HD, BRASS	1
9	106013	WASHER, LOCK 5/16" SPLIT SST	4
10	106026	WASHER, FLAT, 1/4" SST	4
11	106482	WASHER, LOCK 1/4" SPLIT SST	9
12	107967	NUT GRIP, 1/4-20 SST, W/NYLON	3
13	108576	COVER, BOOSTER HEATER, NO CUTOUT	1
14	109985	SEAL, BOOSTER HEATER	3
15	113604	THERMOSTAT, FIXED HI-LIMIT 212°F, 1/2" NPT	1
16	115101	CONNECTOR, MALE, 1/2" NPT X 1/2", 37D FLARE JC BRASS	2
17	116754	THERMISTOR, PROBE, US SENSOR (USP 192261)	1
18	328254	BRACKET, BOOSTER, FRONT SUPPORT	1
19	414331	TANK, BOOSTER	1
20	111885	INSULATION, FISH PAPER	1

BOOSTER HEATING ELEMENTS			
VOLTAGE	TOP ELEMENT (9kW)	BTM ELEMENTS (6kW)	WIRING COMMENTS
208-220/380	116624	107909	380V WIRED AS WYE, OTHERS AS DELTA
230-240/415	116625	114030	415V WIRED AS WYE, OTHERS AS DELTA
460-480	116626	114031	WIRED AS DELTA
575	116627	114032	WIRED AS DELTA

External Steam Booster Cabinet - Beginning with S/N RP18101727

WIRING JUNCTION BOX FOR  
FIELD MACHINE CONNECTION

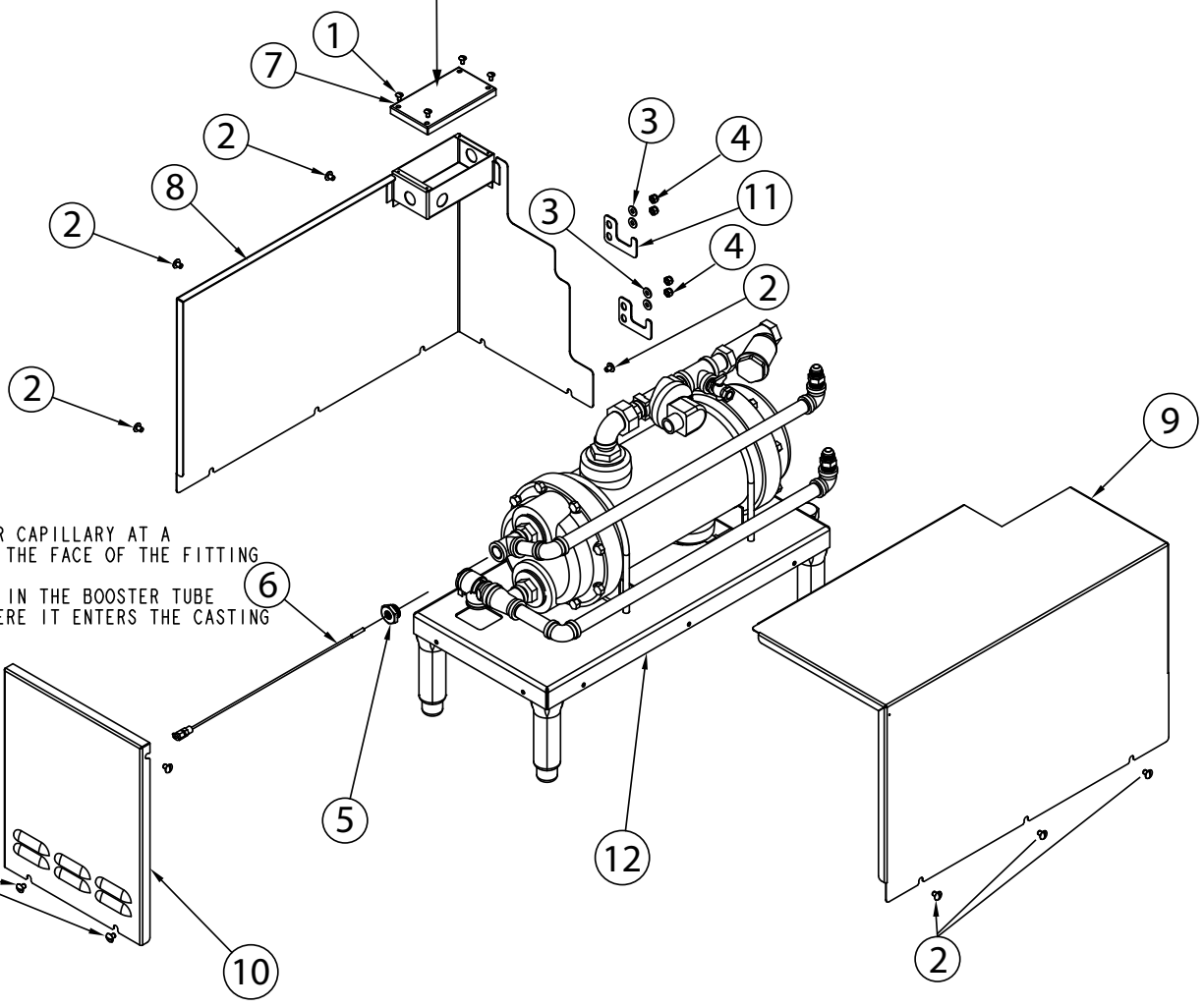

External Steam Booster Cabinet - Beginning with S/N RP18101727

Item No.	Part No.	Description	Qty.
1	100007	SCREW, TRUSS HEAD, 10-32 X 3/8" SST	4
2	100778	SCREW, TRUSS HEAD, 1/4-20 X 3/8" SST	14
3	106026	WASHER, FLAT, 1/4" SST	4
4	107967	GRIP NUT, 1/4-20, SST W/NYLON INSERT	4
5	115530	ADAPTER, THERMOMETER, DIGITAL	1
6	117002	THERMISTER, 10kW 48" LEAD, FLEXIBLE, ADJ. DEPTH.	1
7	339032	COVER, SST STATION, BLANK	1
8	339568	PANEL, WELD, LH, PRO EXTERNAL BOOSTER CABINET	1
9	339571	PANEL, RH PRO EXTERNAL BOOSTER CABINET	1
10	339582	PANEL, FRONT, EXTERNAL BOOSTER CABINET	1
11	339585	PIPING, SUPPORT, WATER, PRO EXT. BSTR, CABINET	2
12	602486	BOOSTER PIPING ASSY. EXT. 1200 STEAM BSTR., PRO	1

# External Steam Booster - Beginning with S/N RP18101727

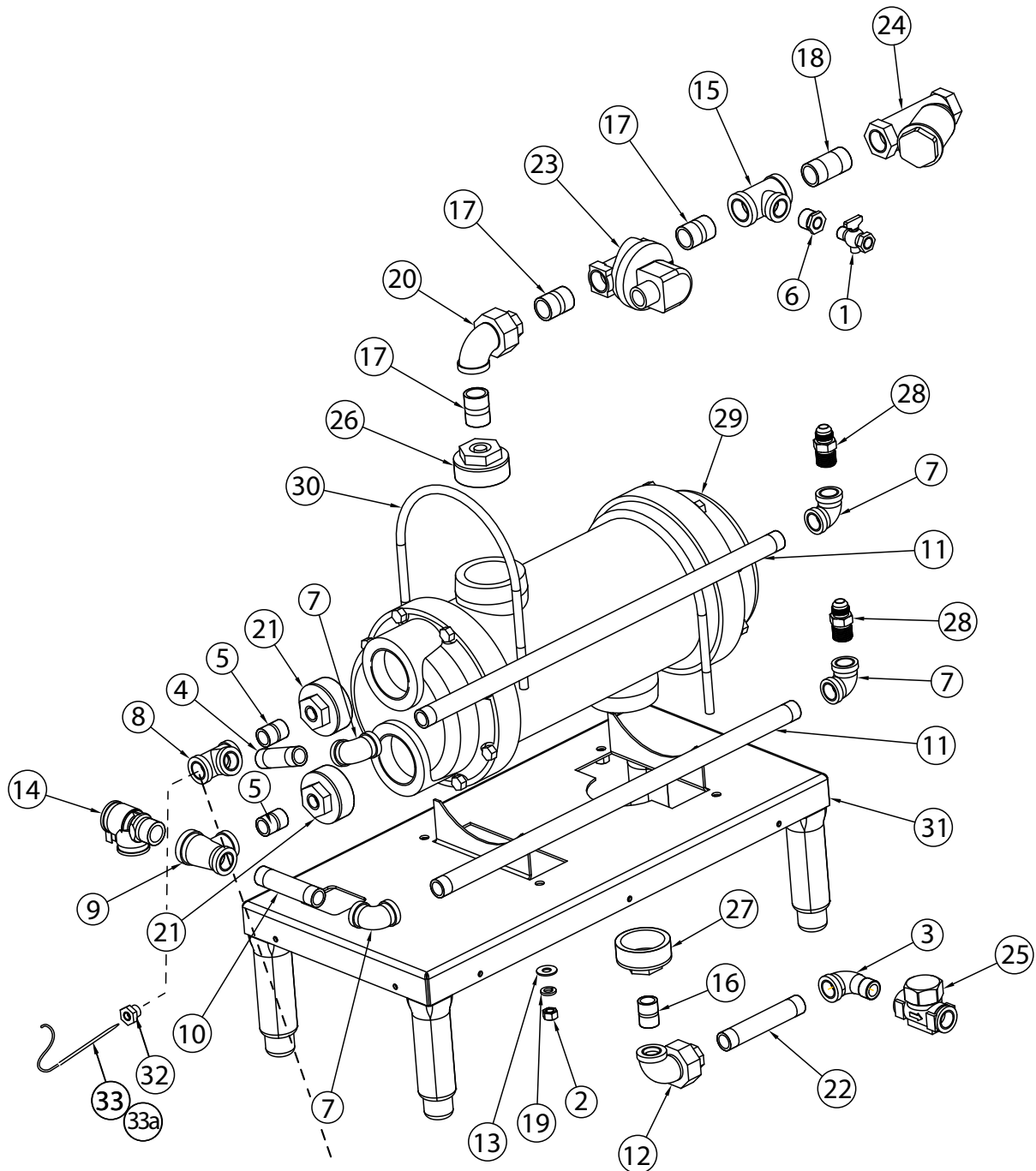

Thermistor capillary will install here at a depth of 16" past the face of the fitting.

External Steam Booster - Beginning with S/N RP18101727

Item No.	Part No.	Description	Qty.
1	100123	PETCOCK. 1/4" NPT FEMALE, BRASS	1
2	100140	PLAIN NUT, 3/8-16 SST	4
3	100147	ELBOW, STREET, 1/2" NPT X 90°, MI	1
4	100206	NIPPLE, 1/2" NPT X 2-1/2" LG., BRASS	1
5	100209	NIPPLE, 1/2" NPT X CLOSE, BRASS	2
6	102402	BUSHING, REDUCING, 1/2" NPT X 1/4" NPT, BI	1
7	102435	ELBOW, 1/2" NPT X 90°, BRASS	4
8	102514	TEE, 1/2" NPT, BRASS	1
9	102524	TEE, RED. 3/4" X 1/2" X 1/2" NPT BRASS	1
10	102569	NIPPLE, 1/2" NPT X 3-1/2" LG., BRASS	1
11	102620	NIPPLE, 1/2" NPT X 21-1/2" NPT, BRASS	2
12	103433	UNION, ELBOW, 1/2" NPT, FEMALE, BI	1
13	104618	WASHER, FLAT 3/8"	4
14	104649	VALVE, PRESSURE RELIEF, 3/4" NPT BRONZE	1
15	105759	TEE, REDUCING, 3/4" NPT X 3/4" NPT X 1/2" MI	1
16	105782	NIPPLE, 1/2" NPT X CLOSE, BI	1
17	105803	NIPPLE, 3/4" NPT X CLOSE, BI	3
18	105806	NIPPLE, 3/4" NPT X 2" LG., BI	1
19	106407	WASHER, LOCK, 3/8" SPLIT, SST	4
20	106485	UNION, ELBOW, 3/4" NPT, FEMALE BI	1
21	106582	BUSHING, REDUCING, 2" NPT X 1/2" NPT, BRASS	2
22	107487	NIPPLE, 1/2" NPT X 4-1/2" LG., BI	1
23	109887	VALVE, SOLENOID, 3/4" NPT STEAM, 120VAC	1
23a	109903	KIT, REPAIR, 3/4" STEAM SOLENOID VALVE	A/R
23b	108516	COIL, SOLENOID, 3/4" 120 VAC	A/R
24	110768	STRAINER, LINE 3/4" NPT BRONZE FEMALE	1
25	111380	TRAP, STEAM 1/2" NPT, TDC	1
26	112341	BUSHING, REDUCING, 2" NPT X 3/4" NPT, BI	1
27	112365	BUSHING, REDUCING, 2" NPT X 1/2" NPT, BI	1
28	115101	CONNECTOR, MALE, 1/2" NPT X 1/2" 37D FLARE JIC BRASS	2
29	115640	BOOSTER, THRUSH #1200	1
30	116676	U-BOLT, #1200 BOOSTER	2
31	339566	BASE, WELD, PRO EXTERNAL, 1200 BOOSTER	1
32	115530	ADAPTER, THERMOMETER	1
33	117002	THERMISTOR, 10KΩ, 40" LEAD, FLEXIBLE DEPTH (Beginning with S/N RP19031884)	1
33a	109069	THERMOSTAT (From S/N RP19031874 to RP19031884)	1

# Steam Coils and Piping

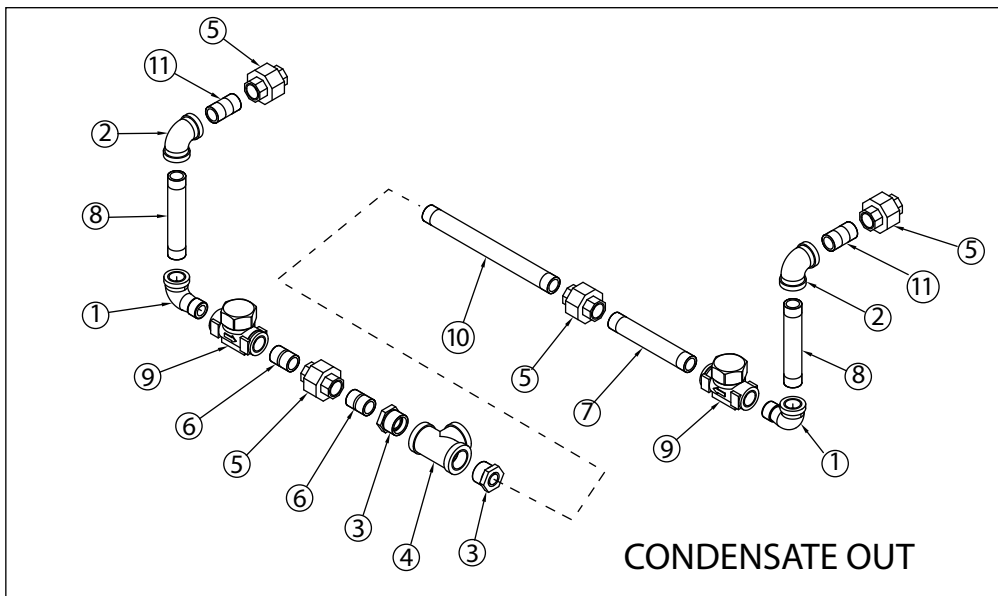
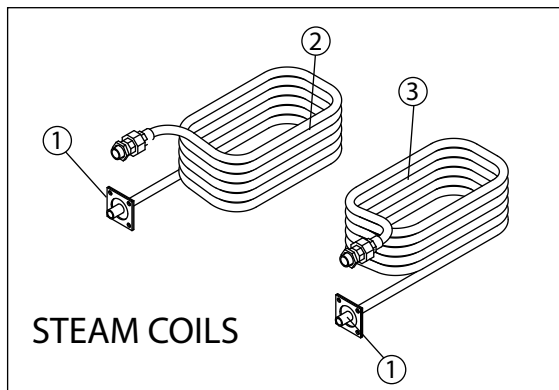
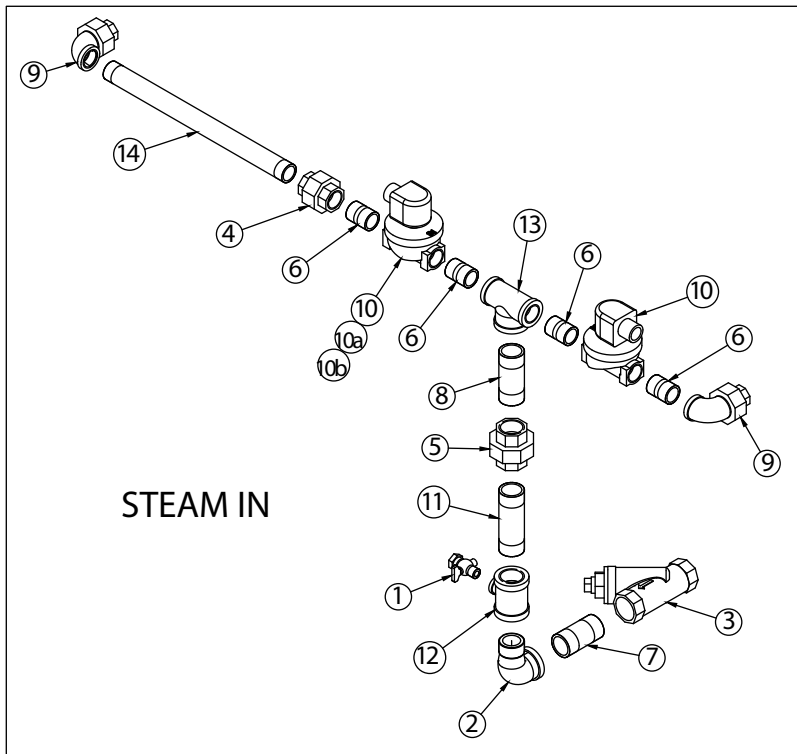



Item No.	Part No.	Description	Qty.
<u>STEAM IN</u>			
1	100123	PETCOCK, 1/4" NPT, FEMALE, BRASS	1
2	100134	ELBOW, STREET, 1" NPT X 90° MI	1
3	101248	LINE STRAINER, 1" NPT BRASS	1
4	105779	UNION, 3/4" NPT, MI	1
5	105780	UNION, 1" NPT, MI	1
6	105803	NIPPLE, 3/4" NPT X CLOSE, BRASS	4
7	105851	NIPPLE, 1" NPT X 2-1/2" LG., BI	1
8	105853	NIPPLE, 1" NPT X 3" LG., BI	1
9	106485	UNION, ELBOW, 3/4" NPT FEMALE	2
10	109887	VALVE, SOLENOID 3/4" NPT STEAM	1
10a	109903	KIT, REPAIR 3/4" STEAM VALVE	A/R
10b	108516	COIL, SOLENOID VALVE 120VAC	A/R
11	109969	NIPPLE, 1" NPT X 3-3/4" LG., BI	1
12	112358	TEE, REDUCING, 1" X 1" X 1/4" NPT, MI	1
13	112359	TEE, RED. 3/4" X 3/4" X 1" NPT BI	1
14	113003	NIPPLE, 3/4" NPT X 13" LG., BI	1
<u>STEAM COILS</u>			
1	108345	GASKET	2
2	327907	COIL, STEAM R-L	1
3	327908	COIL, STEAM L-R	1
<u>CONDENSATE OUT</u>			
1	100147	ELBOW, STREET 1/2" NPT X 90° MI	2
2	102288	ELBOW, 1/2" NPT X 90° MI	2
3	103465	BUSHING, REDUCING, 3/4" NPT X 1/2" NPT BI	2
4	105752	TEE, 3/4" NPT, MI	1
5	105778	UNION, 1/2"NPT, MI	4
6	105782	NIPPLE, 1/2" NPT X CLOSE BI	2
7	105793	NIPPLE, 1/2" NPT X 5" LG., BI	1
8	107487	NIPPLE, 1/2" NPT X 4-1/2" LG., BI	2
9	111380	STEAM TRAP, 1/2" NPT TDC	2
10	111489	NIPPLE, 1/2" NPT X 8-1/4" LG., BI	1
11	113643	NIPPLE, 1/2" NPT X 1-1/2" LG., BI	2

# Heat Recovery Unit Coil

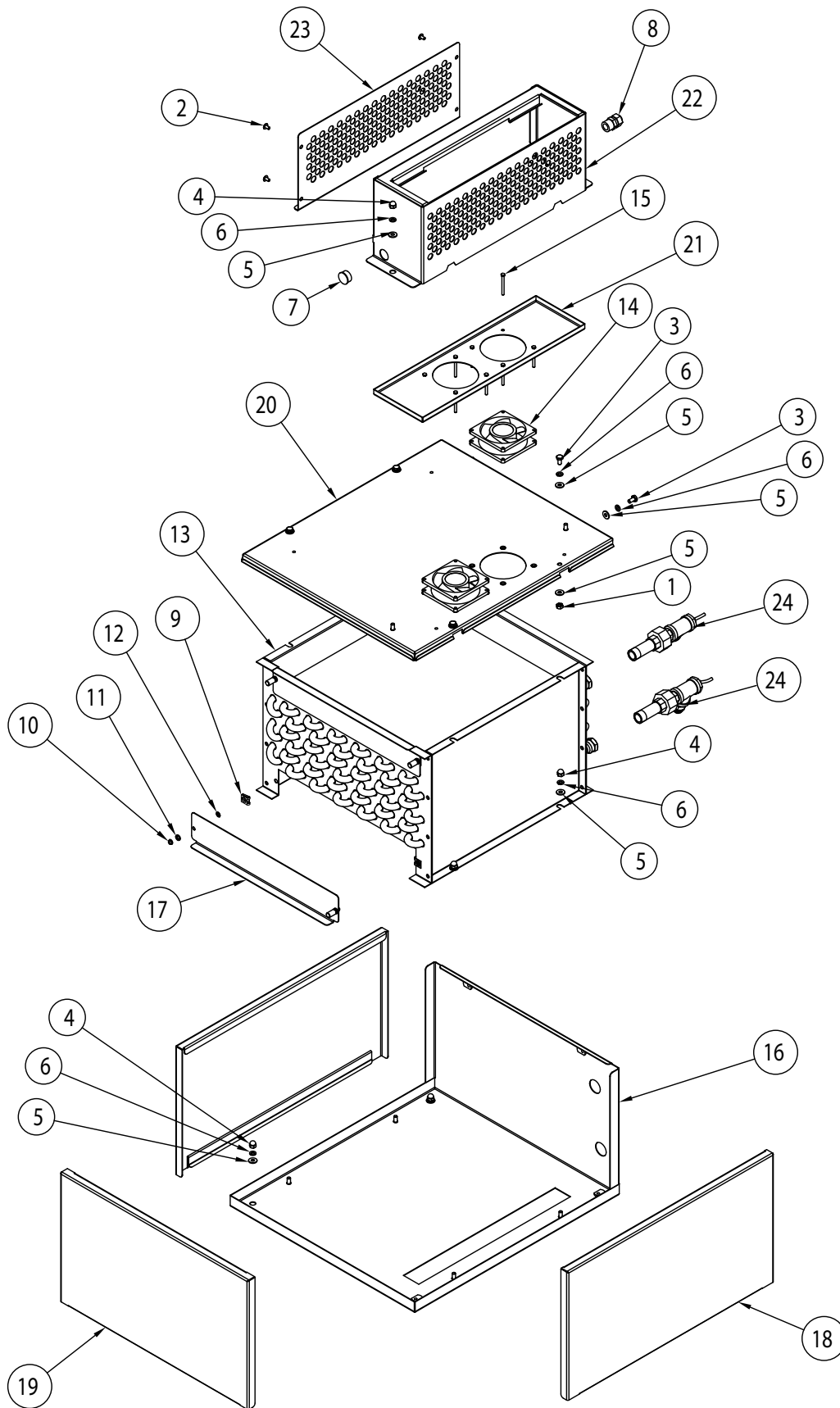

Item No.	Part No.	Description	Qty.
1	100003	NUT PLAIN, 1/4-20 SST	4
2	100007	SCREW, TRUSS HEAD, 10-32 X 3/8" SST	4
3	100734	BOLT, HEX HEAD, 1/4-20 X 1/2" SST	6
4	106014	NUT, ACORN, 1/4-20 SST	8
5	106026	WASHER, FLAT, 1/4" SST	18
6	106482	WASHER, LOCK, 1/4" SPLIT SST	14
7	112519	PLUG, SNAP, D-FLAT	1
8	114365	CORD GRIP, LIQUID TITE, W/LOCKNUT 1/2" NPT	1
9	114646	RECEPTACLE, 1/4 TURN, #82	4
10	114647	SPRING, 1/4 TURN, SST #82	4
11	114648	WASHER, WEAR, CUPPED, #82	4
12	114649	RING, RETAINER, SST, #82	4
13	116911	COIL, ASSEMBLY, PRO RACK, HRU	1
14	116953	FAN. NMB. 24VDC, 105.9 CFM	2
15	116954	BOLT, HEX HEAD, 8-32 X 1-3/4" SST	8
16	339109	COIL, BASE WELD, PRO HRU, LR	1
17	339111	CLEANING, ACCESS, COVER, DEVP., PRO HRU	2
18	339114	SIDE COVER, WELD, PRO HRU	2
19	339116	FRONT COVER, WELD., PRO HRU	1
20	339270	TOP COVER, WELD., PRO HRU	1
21	339282	VENT STACK, DRAIN PAN DEVP., PRO HRU	1
22	339288	VENT STACK, WELD., PRO HRU	1
23	339291	FAN, ACCESS PANEL, PRO HRU	1
24	602436	PIPING ASSEMBLY, HRU CONNECT, PRO HRU	2

# Heat Recovery Unit Standard Hood Vent Cowl

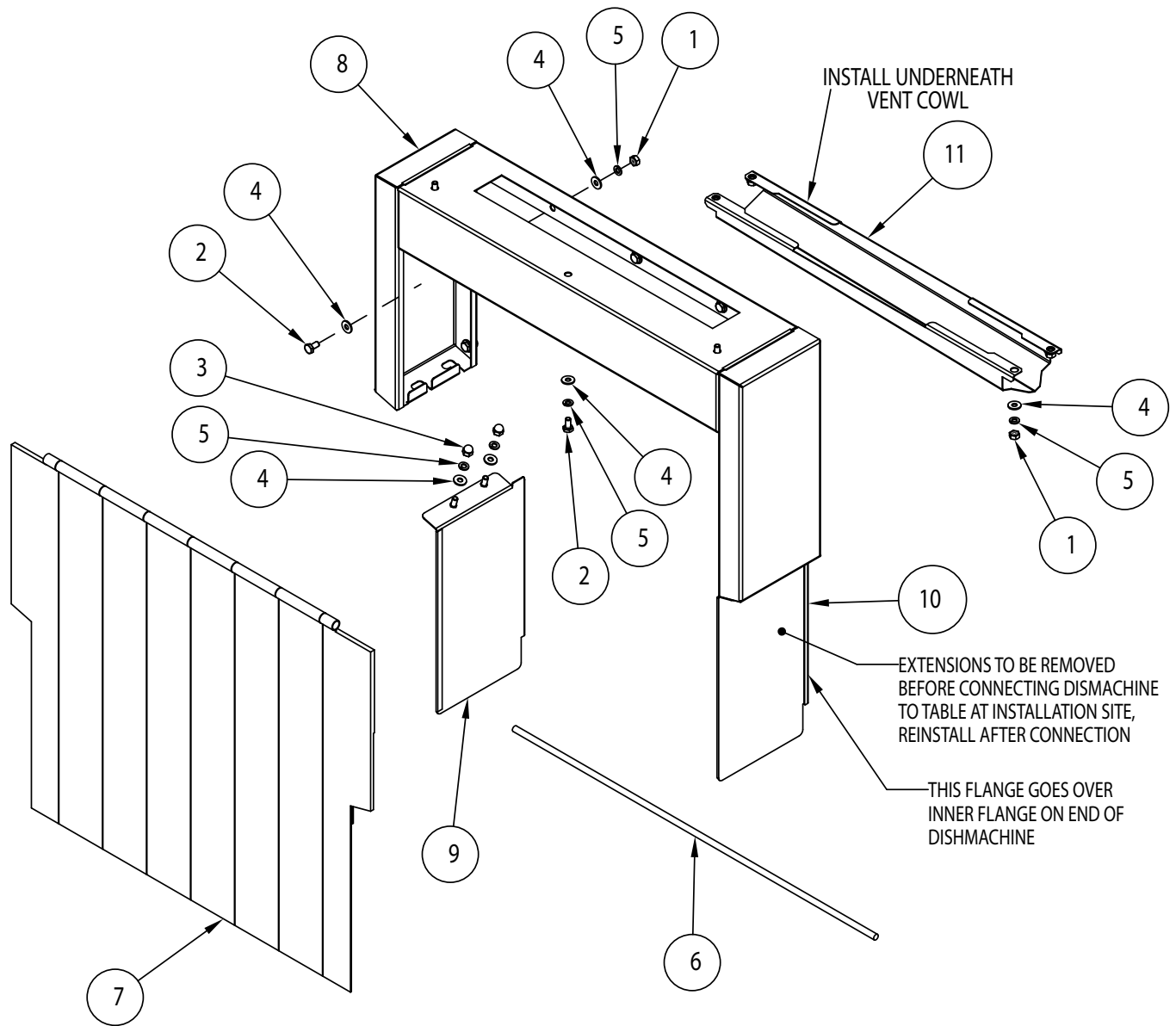

## Heat Recovery Unit Standard Hood Vent Cowl

Item No.	Part No.	Description	Qty.
1	100003	HEX PLAIN NUT, 1/4-20 SST	13
2	100734	BOLT, HEX HEAD, 1/4-20 X 1/2" SST	12
3	106014	HEX ACORN PLAIN NUT, 1/4-20 SST	4
4	106026	WASHER, FLAT, 1/4" SST	29
5	106482	WASHER, LOCK, 1/4" SPLIT SST	20
6	108250	ROD, CURTAIN, 5/16 X 24-5/8", 304 SST	1
7	116964	CURTAIN, PRO HRU, VENT COWL, STD HT.	1
8	339106	VENT COWL, WELD., PRO HRU	1
9	339136-1	VENT COWL, EXTENSION WELD., STD. HT. PRO HRU - FAS	1
10	339136-2	VENT COWL, EXTENSION WELD., STD. HT. PRO HRU - FOP	1
11	339281	CONDENSATE, DRAIN PAN DEVP., PRO HRU	1

# Heat Recovery Unit High Hood Vent Cowl

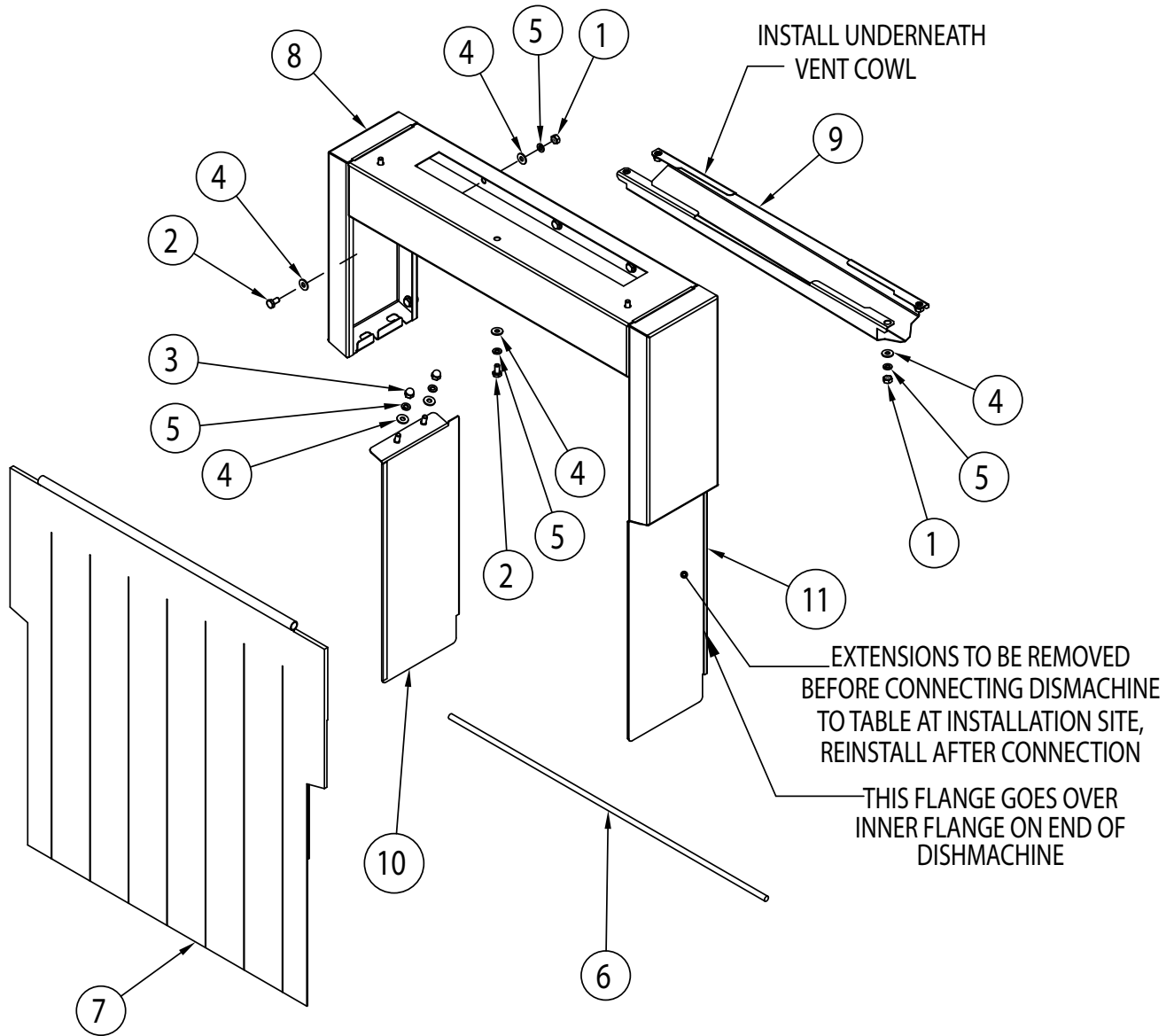

## Heat Recovery Unit High Hood Vent Cowl

Item No.	Part No.	Description	Qty.
1	100003	HEX PLAIN NUT, 1/4-20 SST	13
2	100734	BOLT, HEX HEAD, 1/4-20 X 1/2" SST	12
3	106014	HEX ACORN PLAIN NUT, 1/4-20 SST	4
4	106026	WASHER, FLAT, 1/4" SST	29
5	106482	WASHER, LOCK, 1/4" SPLIT SST	20
6	108250	ROD, CURTAIN, 5/16" X 24-5/18" 304, SST	1
7	117004	CURTAIN, PRO HRU VENT COWL, HH	1
8	339106	VENT COWL WELD., PRO HRU	1
9	339281	CONDENSATE DRAIN PAN, DEVP., PRO HRU	1
10	339397-1	VENT COWL, EXTENSION, WELD., PRO HRU - FAS	1
11	339397-2	VENT COWL, EXTENSION, WELD., PRO HRU - FOP	1

# Standard Vent Cowl/Splash Shields

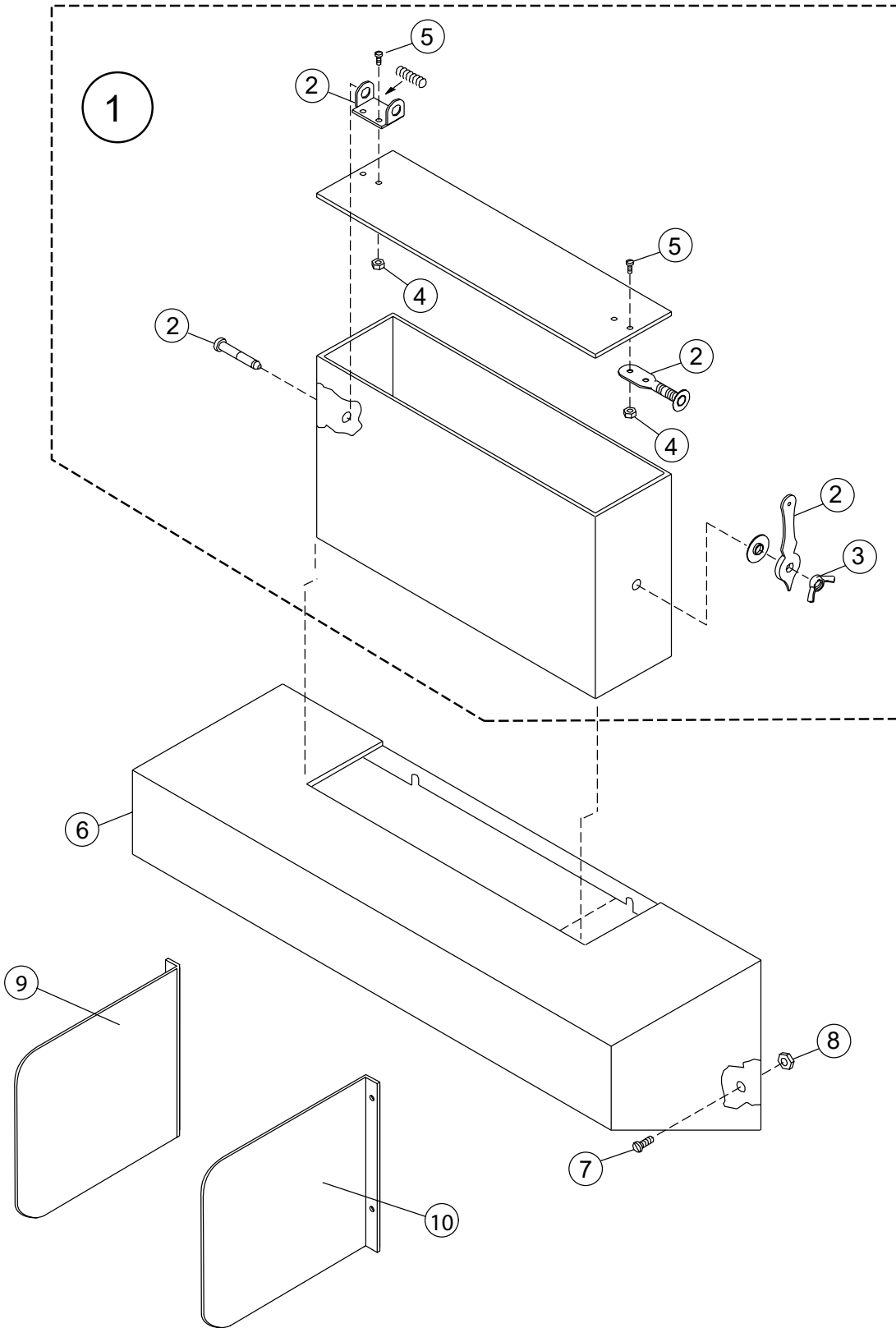



Standard Vent Cowl/Splash Shields

Item No.	Part No.	Description	Qty.
1	401487-S	VENT STACK ASSEMBLY, 4" X 16" (INCLUDES ITEMS 2-6)	2
2	201589	DAMPER, REGULATOR ASSEMBLY	2
3	112258	NUT, WING 1/4-20 SST	2
4	108954	NUT, GRIP 6-32 W/NYLON INSERT	8
5	104883	SCREW 6-32 X 3/8 ROUND HEAD	8
6	337597	VENT COWL, DEVP., SHORT, PRO RACK	2
7	100734	BOLT 1/4-20 X 1/2" HEX HEAD	4
8	100141	NUT GRIP 1/4-20 SST	8
9	328995-1	SHIELD, SPLASH LH	1
10	328995-2	SHIELD, SPLASH RH	1

## Ion Water Conditioner/Drain Water Tempering Kit

### ION WATER CONDITIONER

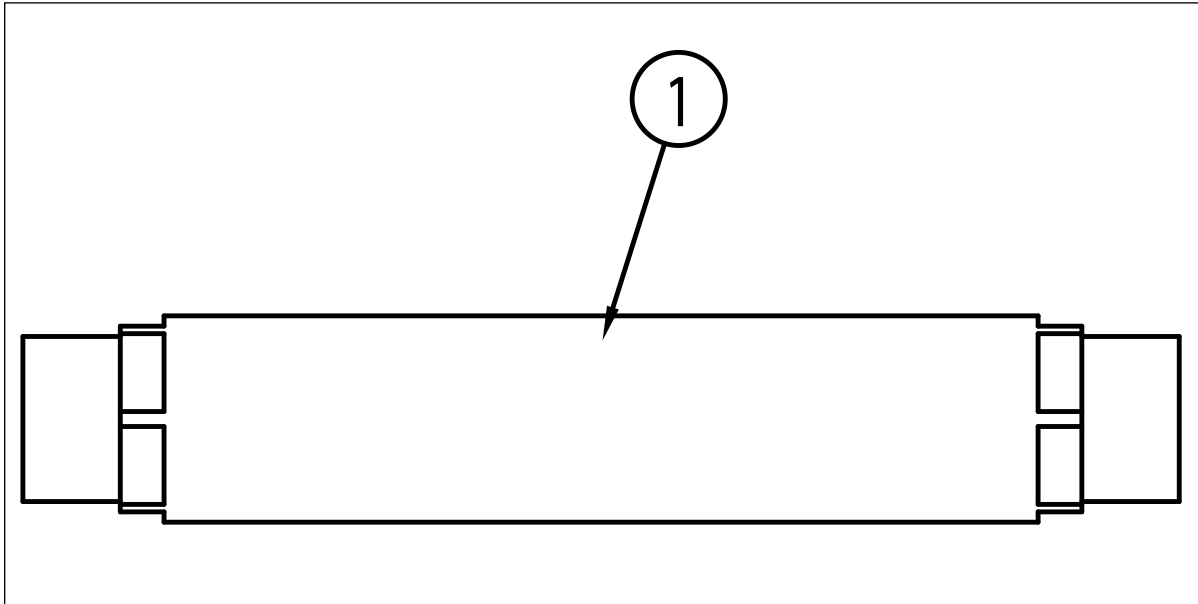

### DRAIN WATER TEMPERING KIT

Note: The kit, P/N 116751, is shipped unmounted for field installation.



## Ion Water Conditioner/Drain Water Tempering Kit

Item No.	Part No.	Description	Qty.
1	115683	WATER CONDITIONER, UNMOUNTED	1

**NOTE: CONTACT FACTORY FOR PROPER ION WATER CONDITIONER SIZE.**

DRAIN WATER TEMPERING KIT, P/N 116751

Note: The kit, P/N 116751, is shipped unmounted for field installation.

# Wash/Prewash Pump and Motor

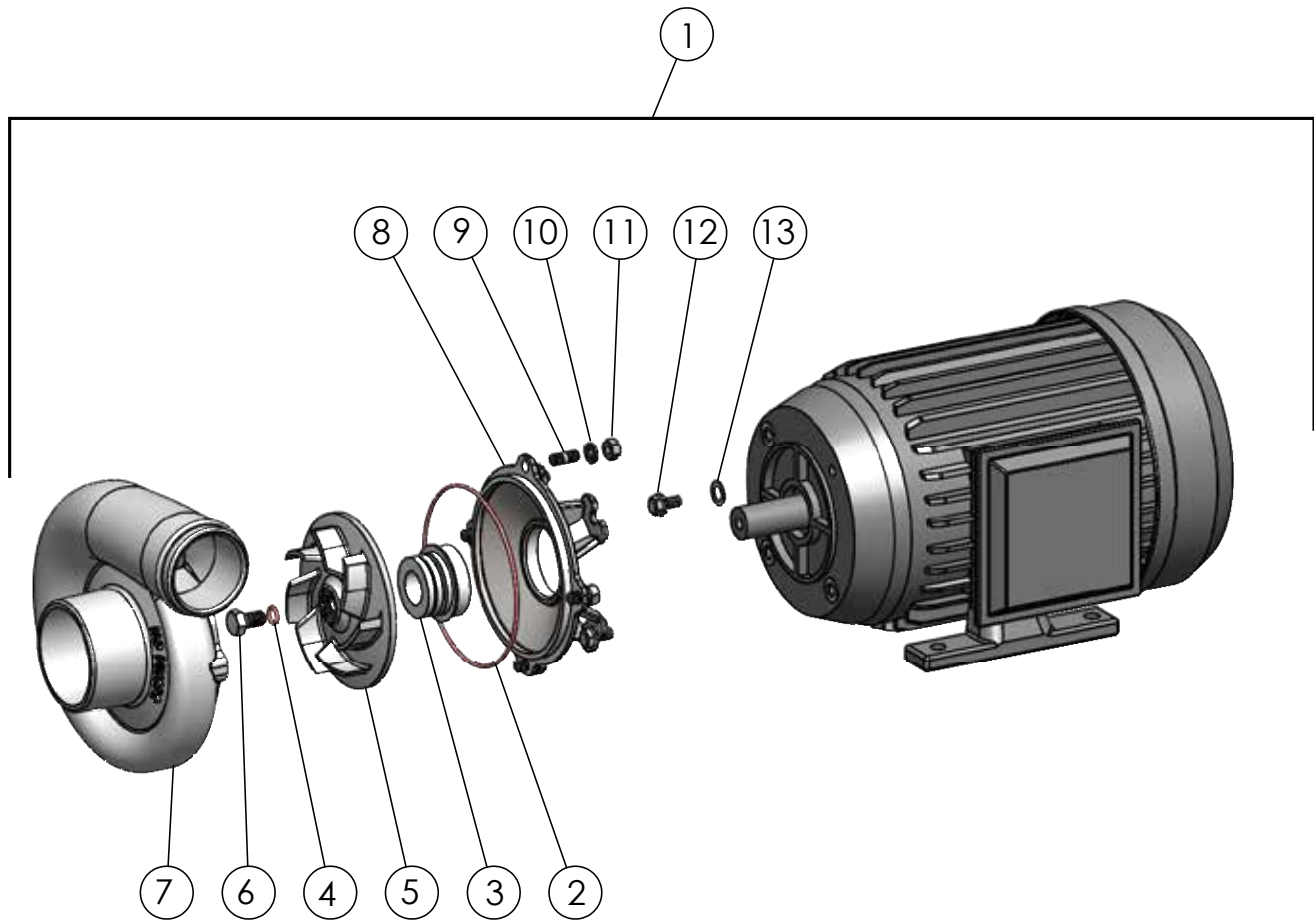

Wash/Prewash Pump and Motor

Item No.	Part No.	Description	Qty.
1*	116520	PREWASH PUMP/MOTOR 1HP, MV/3, COMPLETE	1
---	116680	PREWASH PUMP/MOTOR 1HP, 208/60/1, COMPLETE	1
---	116752	36" PREWASH/PUMP/MOTOR, 2HP MV/3, COMPLETE	1
---	116521	WASH PUMP/MOTOR, 2HP, MV/3, COMPLETE	1
---	116681	WASH PUMP/MOTOR, 1HP 208/60/1, COMPLETE	1
---	116744	PREWASH PUMP/MOTOR 1HP, 575/60/3, COMPLETE	1
---	116745	WASH PUMP/MOTOR 2HP, 575/60/3, COMPLETE	1
2	116729	O-RING, HOUSING	1
3	116730	SEAL	1
4	116757	O-RING, IMPELLER	1
5	116734	IMPELLER, PREWASH PUMP	1
---	116735	IMPELLER, WASH PUMP	1
6	116736	BOLT, M8 X 14 LH	1
7	116737	HOUSING, PUMP	1
8	116738	PLATE, ADAPTER	1
9	116739	STUD, 1/4-20	4
10	116740	WASHER, LOCK 1/4"	4
11	116741	NUT, HEX HEAD 1/4-20	4
12	116742	BOLT	4
13	116743	WASHER	A/R

\* INCLUDES ITEMS 2-13

---	901120	KIT, REPLACEMENT PARTS FOR 1HP PUMP	A/R
---	901121	KIT, REPLACEMENT PARTS FOR 2HP PUMP	A/R
---	116868	MOTOR ONLY, 208/240/480/60/3	A/R
---	116869	MOTOR ONLY, 575/60/3	A/R

## Pump Installations

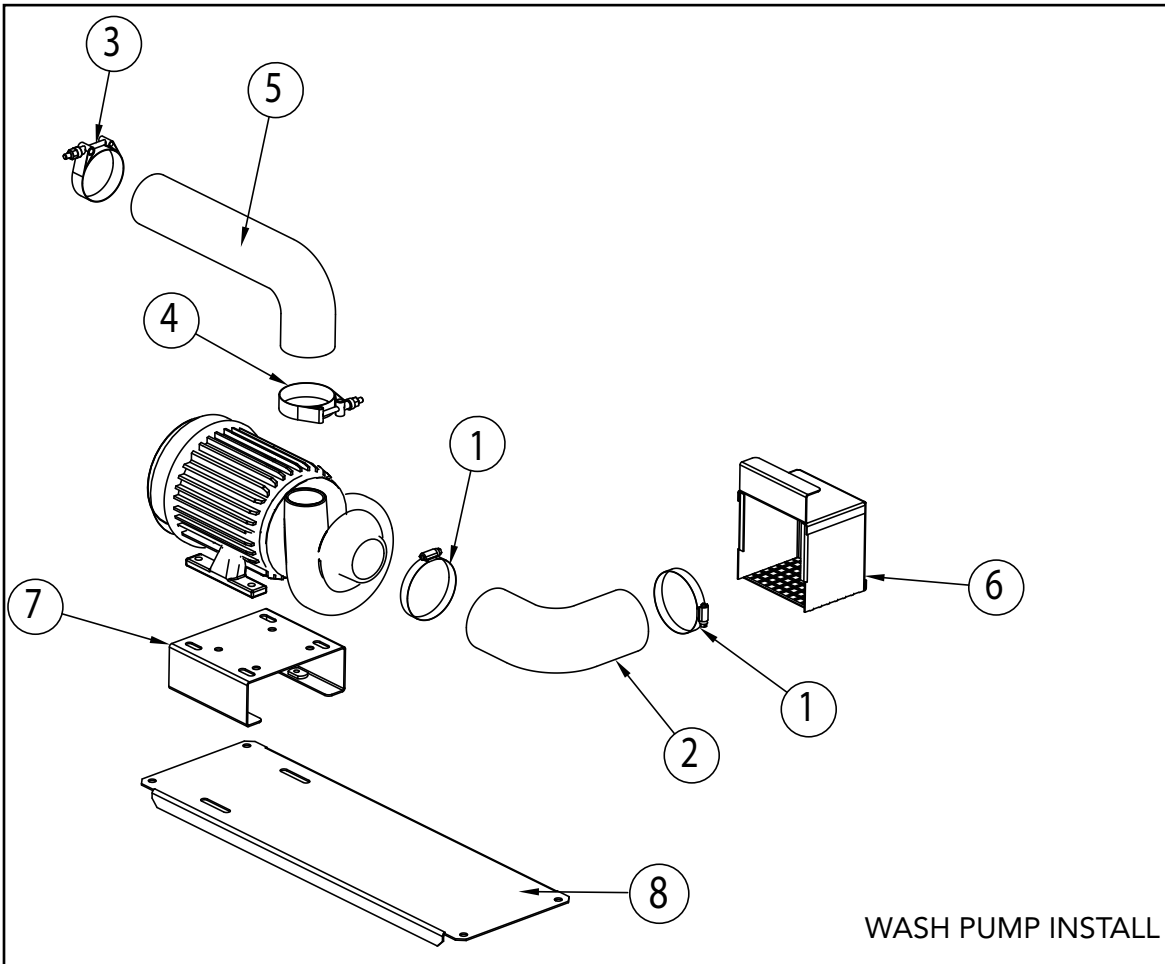
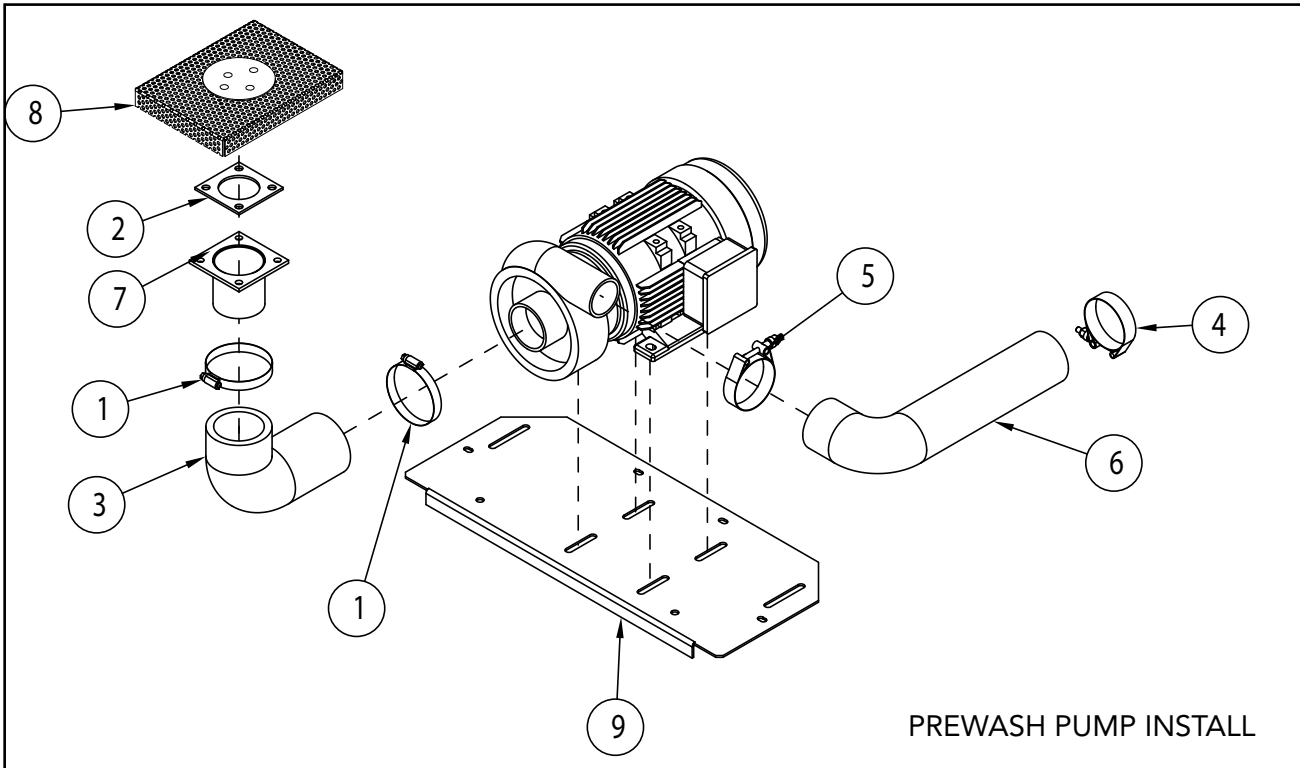

Item No.	Part No.	Description	Qty.
PREWASH INSTALL			
1	104203	CLAMP, HOSE M52 GEAR-TYPE SST	2
2	108345	GASKET	1
3	109562	HOSE, PUMP SUCTION	1
4	110858	HOSE CLAMP, HIGH PRESSURE	1
5	111964	HOSE CLAMP, HIGH PRESSURE	1
6	113731	HOSE, PUMP DISCHARGE	1
7	307995	FLANGE, SUCTION	1
8	324580	SCREEN, SUCTION	1
9	337209	PLATE, PUMP MOTOR SUPPORT 22PRO	1

## WASH INSTALL

1	104203	CLAMP, HOSE M52 GEAR-TYPE SST	2
2	110372	HOSE, PUMP SUCTION	1
3	110858	HOSE CLAMP, HIGH PRESSURE	1
4	111964	HOSE CLAMP, HIGH PRESSURE	1
5	113731	HOSE, PUMP DISCHARGE	1
6	319742	HOOD, PUMP SUCTION	1
7	337060	BRACKET, PUMP MOTOR SUPPORT	1
8	337068	PLATE, PUMP MOTOR SUPPORT	1

# Dish Racks

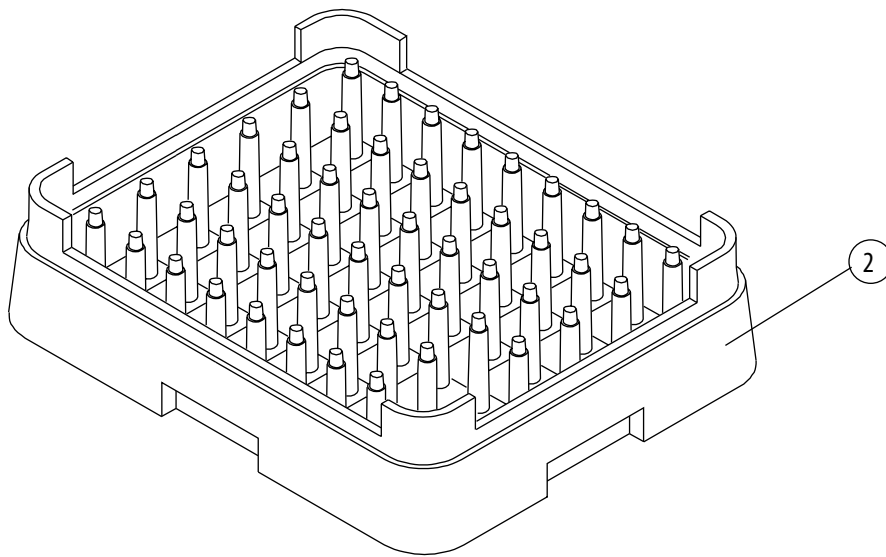
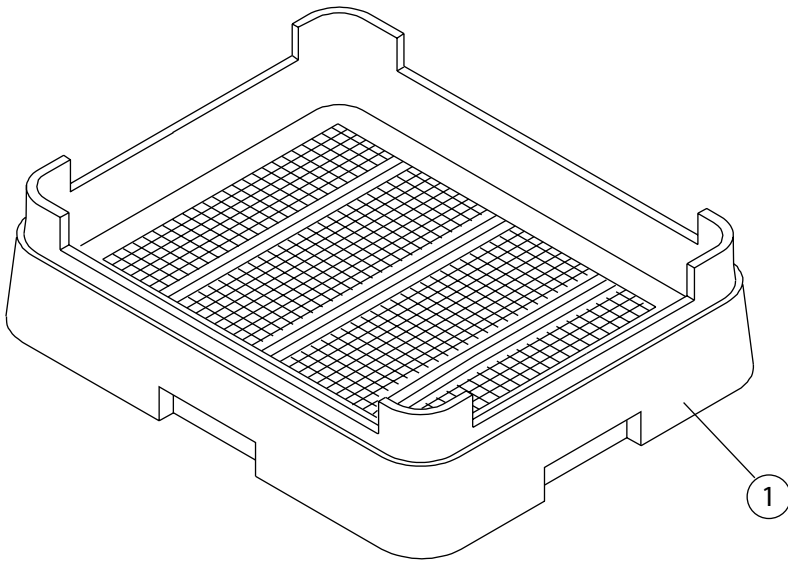



Dish Racks

Item No.	Part No.	Description	Qty.
1	101273	DISH RACK, FLAT-BOTTOM	A/R
2	101285	DISH RACK, PEG	A/R
-	114356	RACK, SHEET PAN, OPEN END (Not Shown)	A/R

**This Page  
Intentionally  
Left Blank**