



Profit from the Eagle Advantage®

# Specification Sheet

## Short Form Specifications

Eagle Pass-Thru Shelf, model \_\_\_\_\_. Constructed of 16 gauge type 304 stainless steel. Rolled edge on front and back, with ends turned down 90°. Heavy gauge support channel with wall brackets included for mounting.

Item No.:	_____
Project No.:	_____
S.I.S. No.:	_____

## Pass-Thru Shelves

### MODELS:

- |   |   |
|---|---|
| <input type="checkbox"/> <b>PTS-1824</b>  | <input type="checkbox"/> <b>PTS-2424</b>  |
| <input type="checkbox"/> <b>PTS-1836</b>  | <input type="checkbox"/> <b>PTS-2436</b>  |
| <input type="checkbox"/> <b>PTS-1848</b>  | <input type="checkbox"/> <b>PTS-2448</b>  |
| <input type="checkbox"/> <b>PTS-1860</b>  | <input type="checkbox"/> <b>PTS-2460</b>  |
| <input type="checkbox"/> <b>PTS-1872</b>  | <input type="checkbox"/> <b>PTS-2472</b>  |
| <input type="checkbox"/> <b>PTS-1884</b>  | <input type="checkbox"/> <b>PTS-2484</b>  |
| <input type="checkbox"/> <b>PTS-1896</b>  | <input type="checkbox"/> <b>PTS-2496</b>  |
| <input type="checkbox"/> <b>PTS-18108</b> | <input type="checkbox"/> <b>PTS-24108</b> |
| <input type="checkbox"/> <b>PTS-18120</b> | <input type="checkbox"/> <b>PTS-24120</b> |
| <input type="checkbox"/> <b>PTS-18132</b> | <input type="checkbox"/> <b>PTS-24132</b> |
| <input type="checkbox"/> <b>PTS-18144</b> | <input type="checkbox"/> <b>PTS-24144</b> |

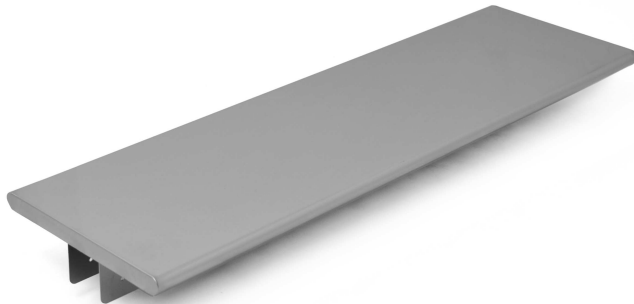

18" x 60" pass-thru shelf

### Design and Construction Features

- Promotes "pass-thru" area from kitchen to serving area.
- 16 gauge type 304 stainless steel shelf top.
- Rolled edge on front and back, with ends turned down 90°.
- Includes heavy gauge galvanized support channel and stainless steel wall angle brackets with self-drilling/self-tapping screws.
- Offered in lengths ranging from 24" to 144" (610 to 3658mm), and 18" or 24" (457 or 610mm) widths.
- Angle brackets allow adjustment for thickness of wall.

### EAGLE GROUP

100 Industrial Boulevard, Clayton, DE 19938-8903 USA  
 Phone: 302-653-3000 • 800-441-8440 • Fax: 302-653-2065  
[www.eaglegrp.com](http://www.eaglegrp.com)  
[www.eaglegrpnews.com](http://www.eaglegrpnews.com)  
[www.eaglemhc.com](http://www.eaglemhc.com)

For custom configuration or fabrication needs, contact our **SpecFAB® Division**.  
 Phone: 302-653-3000 • Fax: 302-653-2065 • e-mail: [quotes@eaglegrp.com](mailto:quotes@eaglegrp.com)



EG02.08A Rev. 03/23

**Spec sheets available for viewing, printing or downloading from our online literature library at our websites**

*Eagle Foodservice Equipment, Eagle MHC, and SpecFAB® are divisions of Eagle Group. ©2023 by the Eagle Group*



Item No.: \_\_\_\_\_  
 Project No.: \_\_\_\_\_  
 S.I.S. No.: \_\_\_\_\_

# Pass-Thru Shelves

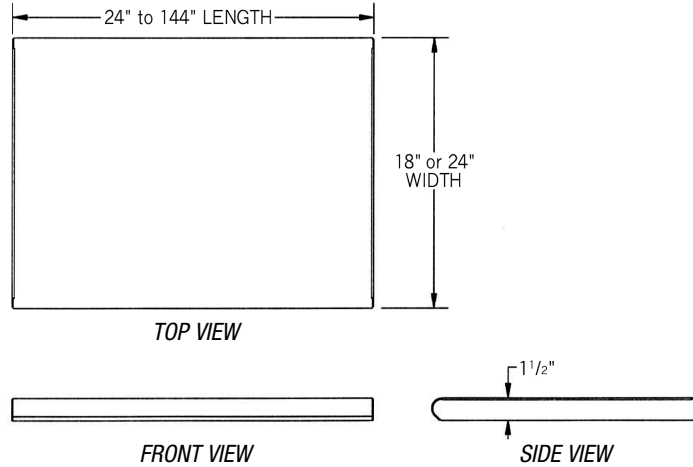

## 18" (457mm)-wide shelves

model #	width x length		weight		maximum wall thickness	
	in.	mm	lbs.	kg	in.	mm
PTS-1824	18" x 24"	457 x 610	24	10.9	10"	254
PTS-1836	18" x 36"	457 x 914	34	15.4	10"	254
PTS-1848	18" x 48"	457 x 1219	44	20.0	10"	254
PTS-1860	18" x 60"	457 x 1524	56	25.4	10"	254
PTS-1872	18" x 72"	457 x 1829	68	30.8	10"	254
PTS-1884	18" x 84"	457 x 2134	81	36.7	10"	254
PTS-1896	18" x 96"	457 x 2438	93	42.2	10"	254
PTS-18108	18" x 108"	457 x 2743	105	47.6	10"	254
PTS-18120	18" x 120"	457 x 3048	117	53.1	10"	254
PTS-18132	18" x 132"	457 x 3353	129	58.5	10"	254
PTS-18144	18" x 144"	457 x 3658	141	64.0	10"	254

## 24" (610mm)-wide shelves

model #	width x length		weight		maximum wall thickness	
	in.	mm	lbs.	kg	in.	mm
PTS-2424	24" x 24"	610 x 610	32	14.5	12"	305
PTS-2436	24" x 36"	610 x 914	42	19.1	12"	305
PTS-2448	24" x 48"	610 x 1219	53	23.6	12"	305
PTS-2460	24" x 60"	610 x 1524	64	29.0	12"	305
PTS-2472	24" x 72"	610 x 1829	76	34.5	12"	305
PTS-2484	24" x 84"	610 x 2134	89	40.4	12"	305
PTS-2496	24" x 96"	610 x 2438	101	45.8	12"	305
PTS-24108	24" x 108"	610 x 2743	113	51.3	12"	305
PTS-24120	24" x 120"	610 x 3048	126	57.2	12"	305
PTS-24132	24" x 132"	610 x 3353	137	62.1	12"	305
PTS-24144	24" x 144"	610 x 3658	149	67.5	12"	305

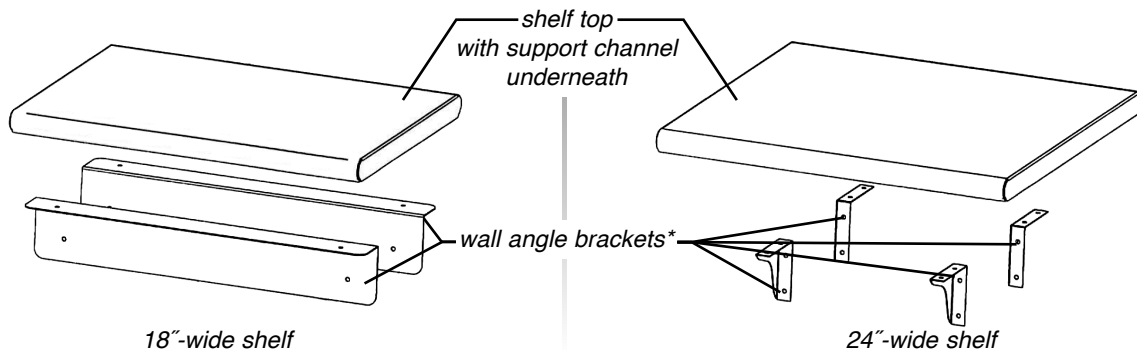

\*Quantity varies per shelf length

### EAGLE GROUP

100 Industrial Boulevard, Clayton, DE 19938-8903 USA

Phone: 302-653-3000 or 800-441-8440 • Fax: 302-653-2065

www.eaglegrp.com • www.eaglegrpnews.com • www.eaglehmc.com

Printed in U.S.A.  
 ©2023 by Eagle Group

Rev. 03/23

Spec sheets available for viewing, printing or downloading from our online literature library at our websites

Although every attempt has been made to ensure the accuracy of the information provided, we cannot be held responsible for typographical or printing errors. Information and specifications are subject to change without notice. Please confirm at time of order.