

- **NE3635RSV** 35-3/4"L x 33"D x 35-3/8"H
- **NE4835RSV** 47-3/4"L x 33"D x 35-3/8"H
- **NE6035RSV** 59-3/4"L x 33"D x 35-3/8"H
- **NE7235RSV** 71-3/4"L x 33"D x 35-3/8"H

Included

- NOTE: Glass warranty only applicable to first point of delivery
- Breeze~E (Type-II) self-contained refrigeration
- (3) Levels of clear glass shelving removable and adjustable on 1" centers
- Condensate pan (self-contained refrig. only)
- LED top & shelf lights
- NOTE: Overall case height is 54-3/4" (includes below counter)
- One piece formed ABS plastic tub
- One year parts & labor; 5 year compressor warranty
- Vertical, fixed front & side UV bonded frameless glass
- Warmest average product temperature of 40°F or less



NE4835RSV

Specify	Standard Features	Additional Options
FRAME EXTERIOR COLOR	• Powder coated Silversan Black	• Powder coated (stock/non-stock colors) • Stainless steel
INTERIOR COLOR	• Powder coated Silversan Black	• NOTE: Interior color must be FDA & NSF approved • Powder coated (stock colors, specify RAL#) • Stainless steel
BASE	• Slide in counter assembly	
LEFT END GLASS	• Glass end	• No end glass w/ synchronized defrost
RIGHT END GLASS	• Glass end	• No end glass w/ synchronized defrost
REAR DOORS	• Clear glass rear sliding doors	• Reflective glass rear sliding doors
LIGHTS	• LED 3500K w/ frosted lens	• LED 3000K w/ frosted lens • LED 4000K w/ frosted lens
ELECTRICAL CONNECTION	• 10' Straight blade power cord (self-cont.)	• 10' Locking power cord (self-cont.) • Electrical leads (remote)
REAR VENTED PANEL	• None	• NOTE: Unit can intake & discharge from rear w/ optional rear vented panel • Powder coated (stock/non-stock colors) • Stainless steel
REFRIGERATION	• Breeze~E (Type-II) self-contained refrigeration (rear access)	• Breeze~E (Type-II) self-contained refrigeration (front access) (see important notes) • Remote w/thermostat, solenoid & TXV (front access) • Remote w/thermostat, solenoid & TXV (rear access)
MISCELLANEOUS		• Rear door lock • Second year parts & labor warranty (excludes compressor)
ACCESSORIES		• Clean Sweep® coil cleaner (self-cont.)

Intended Environment: Type II - Designed to operate in ambient conditions of 80°F and 55% relative humidity unless noted otherwise in system information below.		
Zone	Intended Product To Be Displayed	Warmest Avg Prod Temp ° F
1	Unpackaged refrigerated products	40

PLAN VIEW

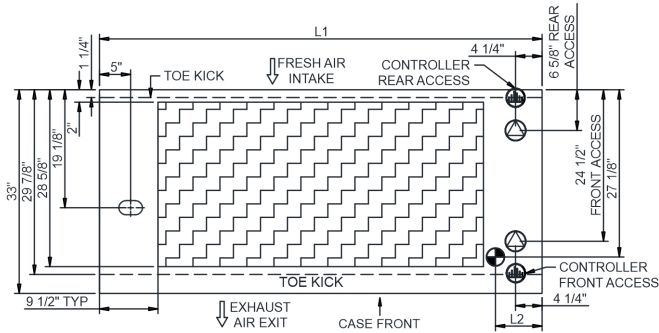

R290 SELF-CONTAINED ACCESS DIMENSIONS PROVIDED.
CONTACT FACTORY FOR ALL OTHER SELF-CONTAINED ACCESS DIMENSIONS

SIDE VIEW

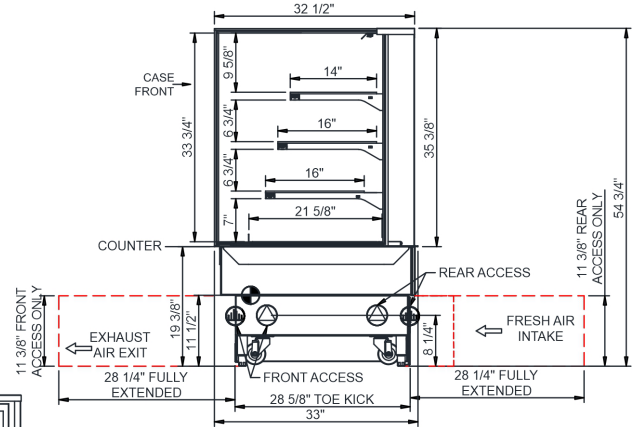

- NOTES:**
- 11 3/8" TALL, FULL WIDTH OF CASE OPENING IN CABINET OR COUNTER IS REQUIRED TO PULL OUT REFRIGERATION SYSTEM.
 - SEE DESIGN GUIDE FOR CUTOUT SIZE IN CABINET FOR CASE TO DROP INTO.
 - BACK OF COUNTER / CABINET MUST BE VENTED PROPERLY FOR ADEQUATE AIRFLOW TO CONDENSER.
 - **REPRESENTS REAR PULLOUT REFRIGERATION. AIR FLOW INTAKE AND EXIT DETAILS ARE REVERSED WITH FRONT PULLOUT REFRIGERATION OPTION.
 - SELF-CONTAINED ACCESS ONLY BY PULLING OUT CONDENSER UNIT.
 - SEE "COUNTER INSTALLATION GUIDE" FOR AIR FLOW REQUIREMENTS.

	"A"	"B"	"C"	"D"		"M"	"N"
NE3635RSV	8 1/2"	16 3/4"	8 1/2"	10 1/2"	NE3635RSV	14 1/2"	32 5/8"
NE4835RSV	8 1/2"	28 3/4"	8 1/2"	10 1/2"	NE4835RSV	20 1/2"	32 5/8"
NE6035RSV	8 1/2"	40 3/4"	8 1/2"	10 1/2"	NE6035RSV	26 1/2"	32 5/8"
NE7235RSV	8 1/2"	52 3/4"	8 1/2"	10 1/2"	NE7235RSV	32 1/2"	32 5/8"

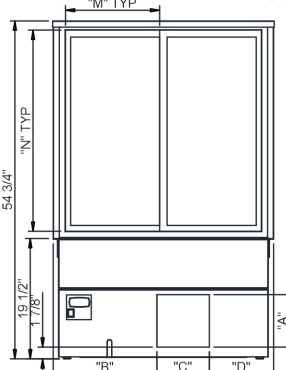

NOTE: ALL DIMENSIONS APPROXIMATE

- ELECTRICAL JUNCTION BOX (SUPPLIED WITH 6" LEADS OR POWER CORD).
- LOCATION OF DRAIN TUBE FOR REMOTE REF. ONLY (SUPPLIED WITH 3/4" OR 1 1/2" PVC TUBE).

- REFRIGERATION LINE CONNECTION.
- REMOTE FLOOR SINK & UTILITIES ACCESS AREA.

- SELF-CONTAINED CASE SERVICE ACCESS AREA.
- DRY CASE SERVICE ACCESS AREA.

Model Technical Specifications																
Model	L"	L1"	L2"	System Circuit Volts			Phs	Freq	Amps ***	Watts	Wires	NEMA Plug	SST	Conv. Rack BTUH	Para. Rack BTUH	Est Wt
				Remote (DX)	Circuit #1	110-120										
NE3635RSV	N/A	35.75	7.50	Remote (DX)	Circuit #1	110-120	1	60	1.08	39	2+G	Leads Single	20.00	1188	1100	700
				Remote (GLYCOL 35%)	Circuit #1	110-120	1	60	1.00	29	2+G	Leads Single	20.00	1188	1100	
				Self-Contained (R290)	Circuit #1	110-120	1	60	10.73	972	2+G	5-15P or L5-15P	N/A	N/A	N/A	
				Self-Contained (R513A)	Circuit #1	110-120	1	60	9.76	769	2+G	5-15P or L5-15P	N/A	N/A	N/A	
NE4835RSV	N/A	47.75	7.50	Remote (DX)	Circuit #1	110-120	1	60	1.08	46	2+G	Leads Single	20.00	1534	1420	1,000
				Remote (GLYCOL 35%)	Circuit #1	110-120	1	60	1.00	36	2+G	Leads Single	20.00	1534	1420	
				Self-Contained (R290)	Circuit #1	110-120	1	60	11.18	1,007	2+G	5-15P or L5-15P	N/A	N/A	N/A	
				Self-Contained (R513A)	Circuit #1	110-120	1	60	9.76	758	2+G	5-15P or L5-15P	N/A	N/A	N/A	
NE6035RSV	N/A	59.75	7.50	Remote (DX)	Circuit #1	110-120	1	60	1.38	66	2+G	Leads Single	24.00	1879	1740	1,100
				Self-Contained (R290)	Circuit #1	110-120	1	60	11.18	1,020	2+G	5-15P or L5-15P	N/A	N/A	N/A	
				Self-Contained (R513A)	Circuit #1	110-120	1	60	9.86	785	2+G	5-15P or L5-15P	N/A	N/A	N/A	
				Self-Contained (R290)	Circuit #1	110-120	1	60	15.48	1,561	2+G	5-15P or L5-15P	N/A	N/A	N/A	
NE7235RSV	N/A	71.75	7.50	Remote (DX)	Circuit #1	110-120	1	60	1.38	73	2+G	Leads Single	20.00	2203	2040	1,200
				Remote (GLYCOL 35%)	Circuit #1	110-120	1	60	1.30	63	2+G	Leads Single	20.00	2203	2040	
				Self-Contained (R290)	Circuit #1	110-120	1	60	15.48	1,561	2+G	5-15P or L5-15P	N/A	N/A	N/A	
				Self-Contained (R513A)	Circuit #1	110-120	1	60	9.86	792	2+G	5-15P or L5-15P	N/A	N/A	N/A	

*** Does not include electric defrost on freezer models.

Regulatory Approvals:	
All Models	Accordance with AHRI Std 1200 ETL Listed to UL 471 ETL Listed to CAN/CSA 22.2 No. 120 ETL Sanitation to NSF/ANSI 7



In Accordance with
AHRI Std 1200

DOE 2017
Energy Efficiency
Compliant



Important Notes:

- 1) ELECTRICAL NOTE: If GFCI is required, a GFCI breaker MUST be used in lieu of a GFCI receptacle
- 2) Verify ventilation requirements for your installation by referring to the Design guide located in our Foodservice Resource Library at structuralconcepts.com.
- 3) Rear Access Standard - Counter must be configured to allow air to be drawn in the rear and discharged out the front.
- 4) Front Access Option - Counter must be configured to allow air to be drawn in the front and discharged out the rear.
- 5) Unit can intake and discharge from rear with optional rear vented panel.
- 6) 19.25" minimum space required beneath counter surface.
- 7) Due to DOE regulations, the maximum counter height on this model is 30".
- 8) Glass warranty only applicable to first point of delivery.

⚠ WARNING: This product can expose you to chemicals, including Urethane (Ethyl Carbamate), which are known to the State of California to cause cancer and birth defects or other reproductive harm. For more information go to www.P65Warnings.ca.gov.