

Item: _____	Model #: _____
Quantity (Qty): _____	Project: _____

P – Range Combo With Manual Griddle

PRM36G-ST



PRM36G-ST

100% manufactured from raw materials to provide the best cooking experience, a high standard of quality, and the highest durability in its class to meet the needs of a commercial kitchen.

STANDARD FEATURES

GRIDDLE

- Stainless steel front and sides.
- 12 gauge splash guards.
- 3/4" (19.05 mm) thick polished carbon steel griddle plate.
- Fully welded griddle plate.
- Enamelled burners placed every 12", providing uniformity when operating.
- Accessible pilots trough front panel.
- Easily removable stainless steel griddle grease trap.

RANGE

- 1-year parts and labor warranty.
- Stainless steel front and sides.
- 12" x 12" cast iron top grates designed for easy movement of pots across top sections.
- Deflectors to direct waste to crumb/drip pan.
- Landing ledge, promoting safety and great functionality.
- Black paint injected aluminum knobs providing for better toughness and durability.
- Stainless steel 25" flue riser & lift-off heavy-duty shelf.
- Easily removable stainless steel crumb/drip pan.

CERTIFICATION:



OVEN

- Oven with snap action thermostat from 210°F to 550°F and 100% safety shut off.
- 26 1/2" Standard bakery depth on all ovens.
- Double-sided enamel oven cavity (Exterior and interior top, bottom, and side).
- Heavy-duty oven wired rack – 1/8" diameter.
- The standard oven has 3 shelf positions and 1 racks.
- Counterweight balanced doors.

AREA FOR CONSULTANT / CONTRACTOR:

OPTIONS & ACCESSORIES

- (4) 6" swivel casters with front locking brakes.
- Additional oven Rack.
- Quick disconnect (3/4 Flex hose quick disconnect 4' long with install kit).
- Stub Back Flue Riser 4".

P – Range Combo With Manual Griddle

PRM36G-ST

P – Range Combo With Manual Griddle

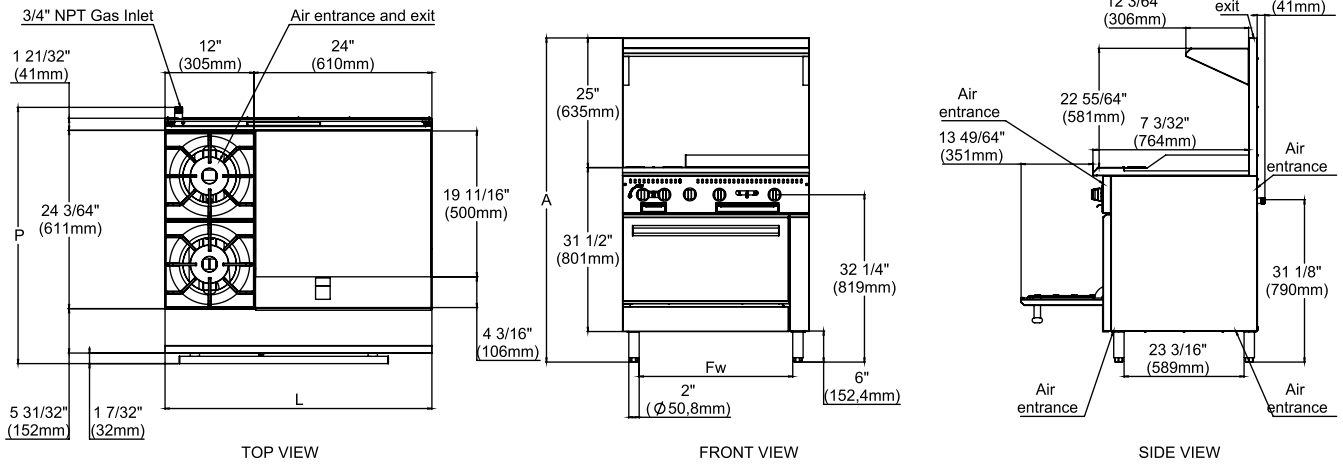

Models	Exterior Product Dimensions & Weight					Shipping Crate Dimensions & Weight				Oven - Inside		
	Width (W)	Depth (D)	Height (H)	Fw	Weight	Width	Depth	Height	Weight	Width	Depth	Height
PRM36G – ST	36" (915 mm)	35" (889 mm)	62 33/64" (1588 mm)	29 39/64" (752 mm)	418 lb (190 kg)	40 9/16" (1030 mm)	45 3/4" (1162 mm)	47 3/32" (1196 mm)	549 lb (248kg)	26 31/32" (685 mm)	26 1/2" (673 mm)	15 23/64" (390 mm)

UTILITY INFORMATION

GAS SUPPLY						
Models	Burners	Natural	Propane	Manifold Pressure		
		BTU/h	BTU/h	Natural Gas	Propane Gas	
PRM36G-ST	Open Burners 12"	2	56,000	56,000	4" W.C	10" W.C
	Griddle 24"	2	60,000	60,000		
	Oven 36"	1	35,000	33,000		

SPECIFICATIONS

- Manifold pressure is 4" W.C (Natural Gas) or 10" W.C (Propane Gas).
- 3/4" NPT rear gas connection and pressure regulator for both natural gas and propane.
- Check the altitude specifications above 2,000 ft.

***NOTE:** In line with its policy to continually improve its product, Venancio USA reserves the right to change materials and specifications without notice.

- Specify the type of gas when ordering.

INSTALLATION INSTRUCTIONS

A pressure regulator sized for this unit is included. The gas line connecting to the range must be 3/4" or larger. If flexible connectors are used, the inside diameter must be 3/4" or larger. An adequate ventilation system is required for commercial cooking equipment. Information may be obtained by writing to the National Fire Protection Association, 1 Batterymarch Park, Quincy, MA 02269, www.NFPA.org. When writing, refer to NFPA No. 96.4. These units are manufactured for installation in accordance with ANSZ223.1A (latest edition), National Fuel Gas Code. Copies may be obtained from The American Gas Association, 400 N Capitol St. NW, Washington, DC 20001, www.AGA.org.