

## "ST4R5-GBK" STAINLESS STEEL TOP WORK TABLES

### 14GA Top w/5" Riser & Galvanized Legs & Adjustable Bracing

#### FEATURES:

- 14GA Stainless Steel Top w/5" Riser & Turndown
- Type 300 Stainless Steel With #4 Polish, Satin Finish
- Top Is Sound Deadened
- Reinforced With 1"x2" Channel Running Entire Length Of Table
- 1-1/2" Stallion Edge On Front Side Edges 90 Degree Bend Down For Table Line-Up
- Galvanized Base With Adjustable Bracing
- Shipped Knocked-Down, Easy-To-Assemble

#### SPECIFICATIONS:

- Top: Stainless Steel Tops Are TIG Welded, Exposed Welds Are Polished To Match Adjacent Surface
- Top: 14GA Stainless Steel Type 300 Stainless Steel With #4 Polish, Satin Finish
- Bracing: 1-1/4" Round O.D. 18GA Galvanized Steel
- Legs: 1-5/8" Round O.D. 16GA Tubular Galvanized Steel
- Gussets: Galvanized Steel
- Feet: 1" Adjustable Stainless Steel Bullet Feet

#### CERTIFICATIONS:



ST4R5-3048GBK

#### ACCESSORIES

##### DESCRIPTION

- Drawer
- Drawer Lock
- Casters
- Overshelves
- Sinks
- Pot Rack

### "ST4R5-GBK" STAINLESS STEEL TOP WORK TABLES

LENGTH	24" WIDE	WT	WT CAP	30" WIDE	WT	WT CAP	36" WIDE	WT	WT CAP
24"	ST4R5-2424GBK	44	900	ST4R5-3024GBK	49	900	ST4R5-3624GBK	55	900
30"	ST4R5-2430GBK	49	900	ST4R5-3030GBK	55	900	ST4R5-3630GBK	63	900
36"	ST4R5-2436GBK	55	900	ST4R5-3036GBK	61	900	ST4R5-3636GBK	70	900
48"	ST4R5-2448GBK	66	900	ST4R5-3048GBK	74	900	ST4R5-3648GBK	84	900
60"	ST4R5-2460GBK	77	650	ST4R5-3060GBK	87	650	ST4R5-3660GBK	97	650
72"	ST4R5-2472GBK	89	420	ST4R5-3072GBK	99	420	ST4R5-3672GBK	112	420
84"	ST4R5-2484GBK	108	1350	ST4R5-3084GBK	121	1350	ST4R5-3684GBK	138	1350
96"	ST4R5-2496GBK	119	1350	ST4R5-3096GBK	134	1350	ST4R5-3696GBK	153	1350
108"	ST4R5-24108GBK	129	1350	ST4R5-30108GBK	146	1350	ST4R5-36108GBK	166	1350
120"	ST4R5-24120GBK	141	1200	ST4R5-30120GBK	159	1200	ST4R5-36120GBK	180	1200
132"	ST4R5-24132GBK	152	960	ST4R5-30132GBK	171	960	ST4R5-36132GBK	195	960
144"	ST4R5-24144GBK	164	750	ST4R5-30144GBK	185	750	ST4R5-36144GBK	211	750

OVERALL WEIGHT (WT) AND MAX WEIGHT CAPACITY (WT CAP) ARE IN POUNDS (LBS). MAX WEIGHT CAPACITY EVENLY DISTRIBUTED. ALL DIMENSIONS ARE TYPICAL. TOLERANCE +/- .500". JOHN BOOS & CO. RESERVES THE RIGHT TO CHANGE SPECIFICATIONS WITHOUT NOTICE.

# DETAILED SPECIFICATIONS

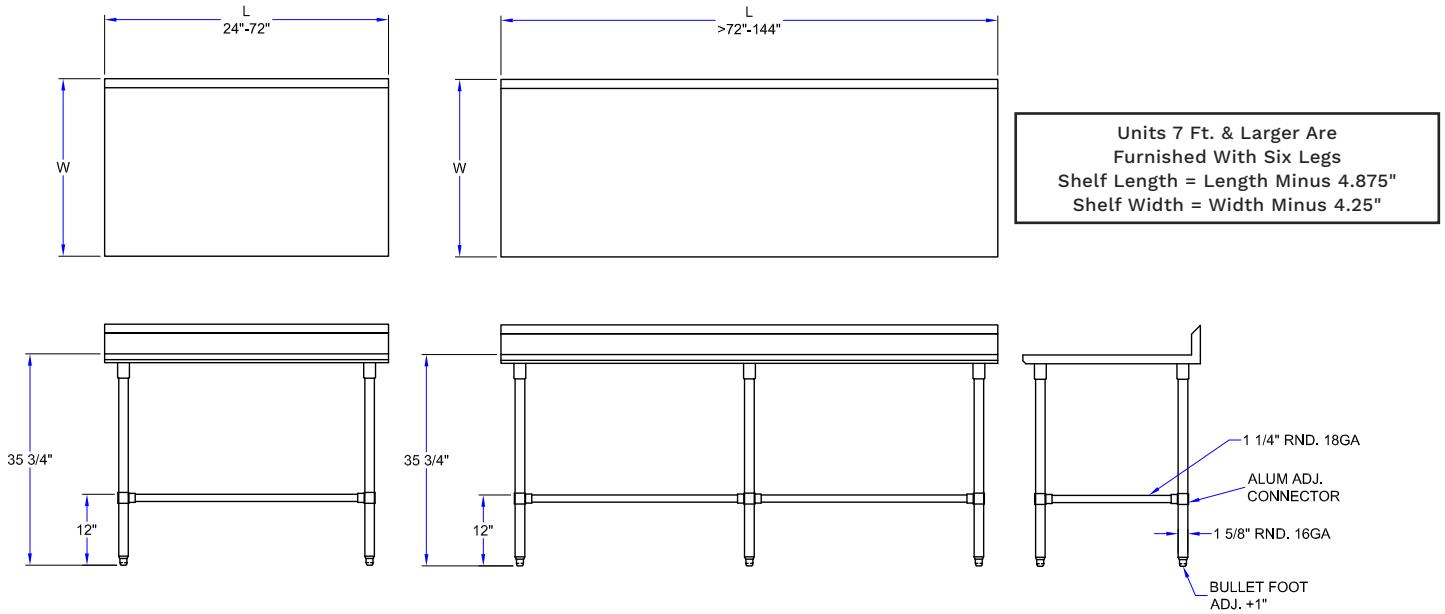

## MODEL # STRUCTURE

5 = Ht. Of Riser w/Turndown

R = Top w/Riser

4 = 14GA Work Surface

ST = Stainless Steel Top

ST4R5-2430GBK

24 = Width Of Work Surface

30 = Length Of Work Surface

GB = Galvanized Legs & Bracing

K = Ships Knocked Down

## "ST4R5-GBK" STAINLESS STEEL TOP WORK TABLES

LENGTH	24" WIDE	WT	WT CAP	30" WIDE	WT	WT CAP	36" WIDE	WT	WT CAP
24"	ST4R5-2424GBK	44	900	ST4R5-3024GBK	49	900	ST4R5-3624GBK	55	900
30"	ST4R5-2430GBK	49	900	ST4R5-3030GBK	55	900	ST4R5-3630GBK	63	900
36"	ST4R5-2436GBK	55	900	ST4R5-3036GBK	61	900	ST4R5-3636GBK	70	900
48"	ST4R5-2448GBK	66	900	ST4R5-3048GBK	74	900	ST4R5-3648GBK	84	900
60"	ST4R5-2460GBK	77	650	ST4R5-3060GBK	87	650	ST4R5-3660GBK	97	650
72"	ST4R5-2472GBK	89	420	ST4R5-3072GBK	99	420	ST4R5-3672GBK	112	420
84"	ST4R5-2484GBK	108	1350	ST4R5-3084GBK	121	1350	ST4R5-3684GBK	138	1350
96"	ST4R5-2496GBK	119	1350	ST4R5-3096GBK	134	1350	ST4R5-3696GBK	153	1350
108"	ST4R5-24108GBK	129	1350	ST4R5-30108GBK	146	1350	ST4R5-36108GBK	166	1350
120"	ST4R5-24120GBK	141	1200	ST4R5-30120GBK	159	1200	ST4R5-36120GBK	180	1200
132"	ST4R5-24132GBK	152	960	ST4R5-30132GBK	171	960	ST4R5-36132GBK	195	960
144"	ST4R5-24144GBK	164	750	ST4R5-30144GBK	185	750	ST4R5-36144GBK	211	750

OVERALL WEIGHT (WT) AND MAX WEIGHT CAPACITY (WT CAP) ARE IN POUNDS (LBS). MAX WEIGHT CAPACITY EVENLY DISTRIBUTED. ALL DIMENSIONS ARE TYPICAL. TOLERANCE +/- .500". JOHN BOOS & CO. RESERVES THE RIGHT TO CHANGE SPECIFICATIONS WITHOUT NOTICE.