

# "BHS5" LAVATORY SHELVES

## 16GA Stainless Steel

**FEATURES:**

- 16GA, Type 300 Stainless Steel With #4 Polish, Satin Finish
- Finished With A Safety Stallion Front Edge
- Flat Top
- Shipped Knocked-Down, Easy-To-Assemble, Most Ship Ups

**SPECIFICATIONS:**

- Stainless Steel Shelves Are TIG Welded
- Exposed Welds Are Polished To Match Adjacent Surface
- Shelf: 16GA, Type 300 Stainless Steel #4 Polish, Satin Finish
- Brackets: 16GA, Type 300 Stainless Steel #4 Polish, Satin Finish



BHS5166

### "BHS5" LAVATORY SHELVES

MODEL	LENGTH (L)	SIZE (L X W X H)	WEIGHT (LBS)
BHS5166	16"	16"x5"x5"	5
BHS5186	18"	18"x5"x5"	6
BHS5246	24"	24"x5"x5"	8
BHS5366	36"	36"x5"x5"	12
BHS5486	48"	48"x5"x5"	16

ALL DIMENSIONS ARE TYPICAL. TOLERANCE +/- .500". JOHN BOOS & CO. RESERVES THE RIGHT TO CHANGE SPECIFICATIONS WITHOUT NOTICE.

# DETAILED SPECIFICATIONS

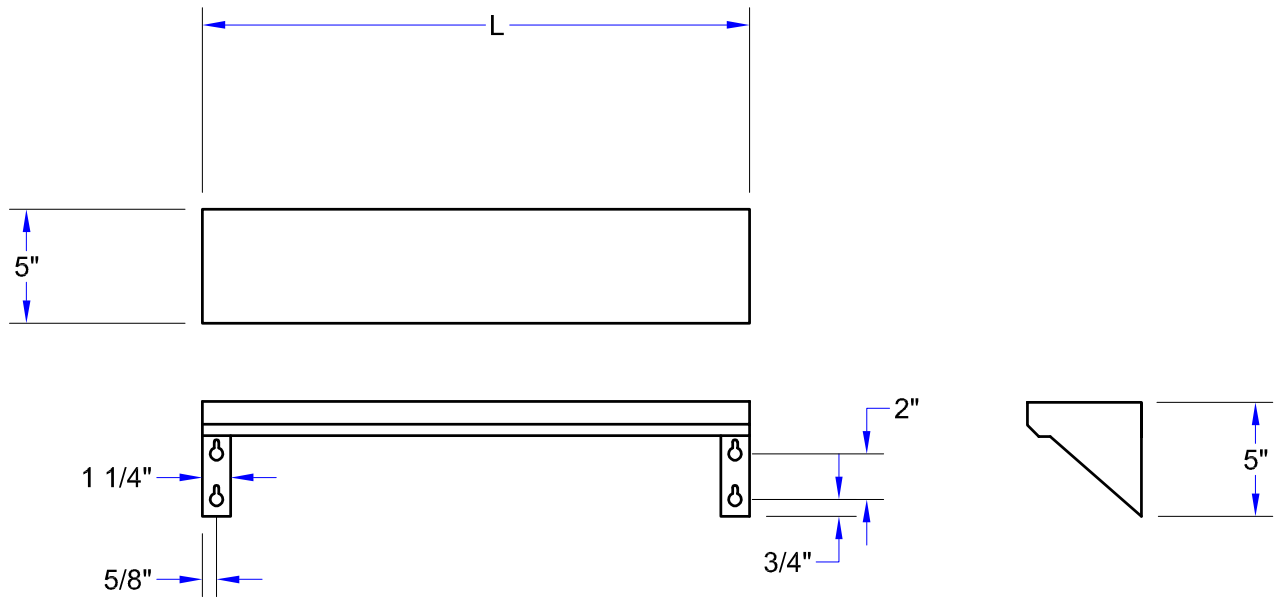

## "BHS5" LAVATORY SHELVES

MODEL	LENGTH (L)	SIZE (L X W X H)	WEIGHT (LBS)
BHS5166	16"	16"x5"x5"	5
BHS5186	18"	18"x5"x5"	6
BHS5246	24"	24"x5"x5"	8
BHS5366	36"	36"x5"x5"	12
BHS5486	48"	48"x5"x5"	16

ALL DIMENSIONS ARE TYPICAL. TOLERANCE +/- .500". JOHN BOOS & CO. RESERVES THE RIGHT TO CHANGE SPECIFICATIONS WITHOUT NOTICE.