



Admiral Craft

Equipment Corp.

NOW IN STOCK!

INCREASE IMPULSE SALES *with* **BLACK◆DIAMOND®** Vertical Air Curtain Merchandisers by Admiral Craft



BDVACM-250



BDVACM-220



BDVACM-200



FEATURES

- Brilliant Internal LED illumination each shelf
- Digital temperature controller and display
- Stainless steel shelf
- 4 casters - 2 braking and 2 non-braking
- Safety glass on 2 sides
- Night curtain
- Ventilated cooling system
- Automatic defrost
- Stainless steel
- Condensation water evaporated automatically

Model Number	BDVACM-200	BDVACM-220	BDVACM-250
Rated Input Power	1360W	1360W	1360W
Shelf Size	37.2"L × 9.45"W	11" × 18"	15" × 21.75" (2pc.) 12" × 21.75" (1pc.)
Storage Volume (Liters)	200L	220L	250L
Overall Dimensions (in)	36.4"L × 25"W × 49.2"H	26.5"L × 19"W × 68.6"H	29.7"L × 24"W × 67"H
Refrigerant	R290a	R290a	R290a
Voltage/Hertz/Phase	110/60/1	110/60/1	110/60/1
Amps	14.5	14.5	14.5
Net Weight (lbs)	253.5 lbs	212 lbs	220.5 lbs
Gross Weight (lbs)	286.6 lbs	233 lbs	243 lbs
Temperature Range (°F)	35.6°F - 50°F	35.6°F - 50°F	35.6°F - 50°F
Lamp Wattage	2.8 Watts (3) LED	1.4 Watts (4) LED	2.5 Watts (4) LED

CALL FOR MORE INFO: 1.800.223.7750

VISIT: www.admiralcraft.com

BLACK DIAMOND®

Vertical Air Curtain Merchandisers

by Admiral Craft

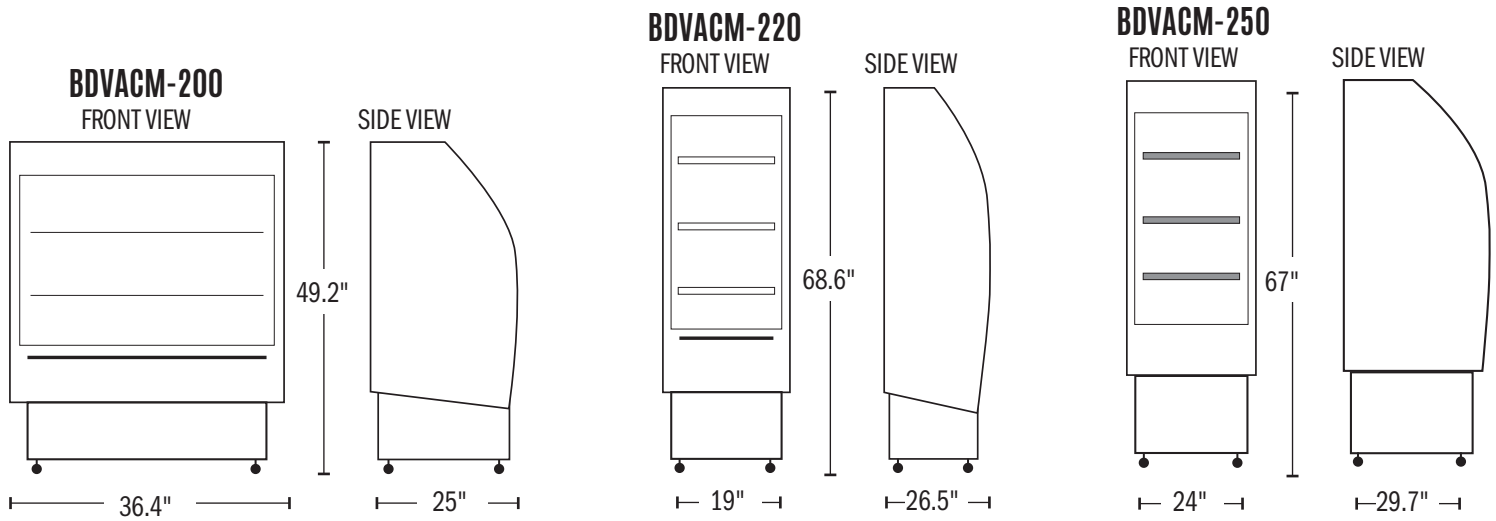

REFRIGERATION SYSTEM

- R404a refrigerant
- Ventilated cooling system
- Automatic defrost
- Temperature range of 35.6° F - 50° F

ELECTRICAL CONTROL

- Digital temperature controller and displays make it easy to adjust and view the internal temperature

CABINET CONSTRUCTION

- Stainless steel body and shelves
- Safety glass on two sides

SHELVING

- Stainless Steel Shelves

MODEL FEATURES

- Night curtain helps kaporated automatically
- 4 casters (2 braking and 2 non-braking)
- Condensation water evaporated automatically

Warranty

All Black Diamond Refrigerators and Freezers are backed by a one-year parts and labor warranty