



ADA Compliant

This Space for Architect/Engineer Approval

Job Name _____ Date _____

Model Specified _____ Quantity _____

Customer/Wholesaler _____

Contractor _____

Architect/Engineer _____

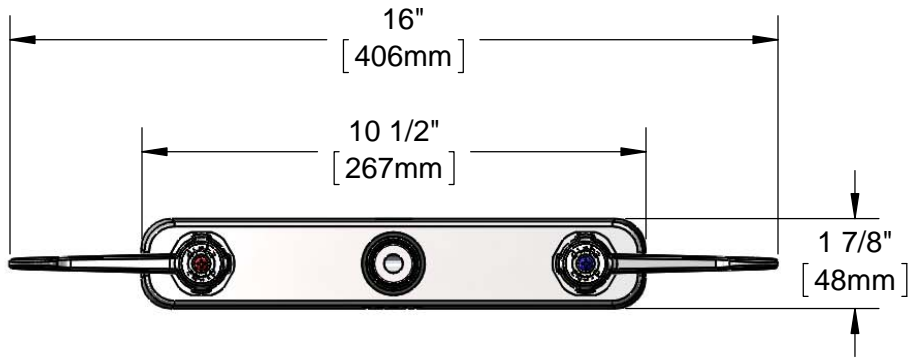
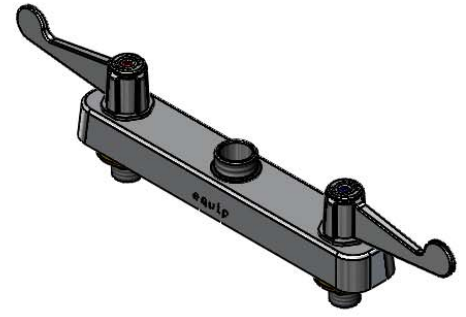

Swivel Outlet Accepts equip Swivel Nozzles. Rigid Conversion Requires 014200-45 Lock Washer (Sold Separately)

Ceramic Cartridges & equip 4" Wrist Action Handles w/ Color Coded Screws

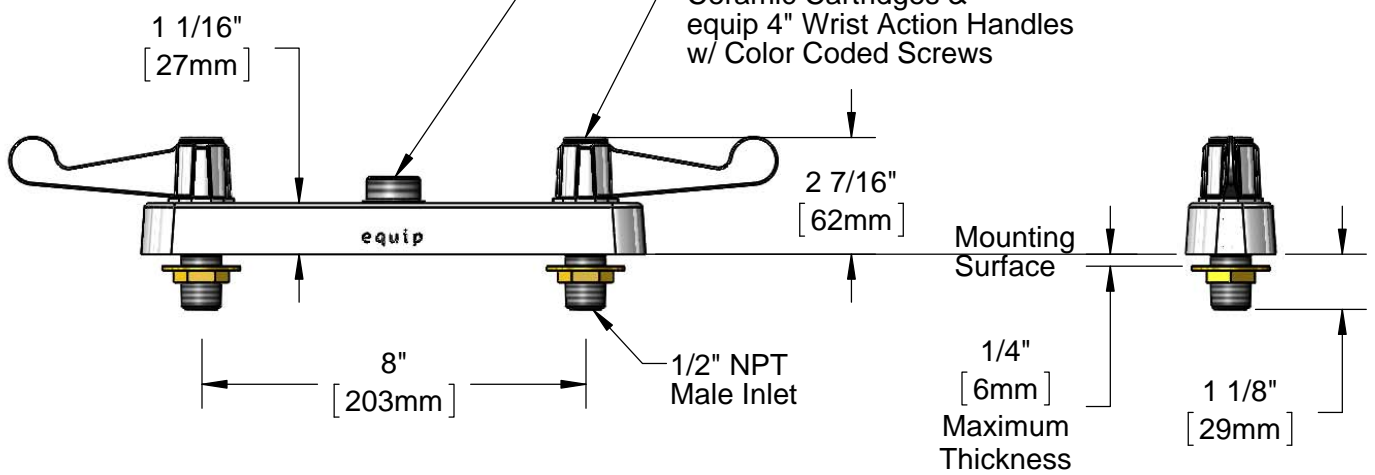

Rough-In Requirement:
(2) \varnothing 1" [25mm] Mounting Holes

Model Number
5F-8CW00

Product Specifications:
8" Deck Mount Workboard Mixing Faucet Less Nozzle w/ Ceramic Cartridges, equip 4" Wrist Action Handles & 1/2" NPT Male Inlets

Product Compliance:
ASME A112.18.1 / CSA B125.1
NSF 61 - Section 9
NSF 372 (Low Lead Content)
ANSI A117.1 (ADA)

equip Foodservice Accessories



2 Saddleback Cove, P.O. Box 1088
Travelers Rest, South Carolina 29690
Phone: 800.891.4808 Fax: 800.868.0084
equip.tsbrass.com

ITEM NO.	SALES NO.	DESCRIPTION
1	5-HDL-W	equip 4" Wrist Action Handle w/ Color Coded Screws
2	013788-45	equip Ceramic Cartridge, LTC
3	000999-45	Brass Lock Washer
4	002954-45	Shank Lock Nut
5	017587-45	Swivel Nut Seal
6	013787-45	equip Ceramic Cartridge, RTC

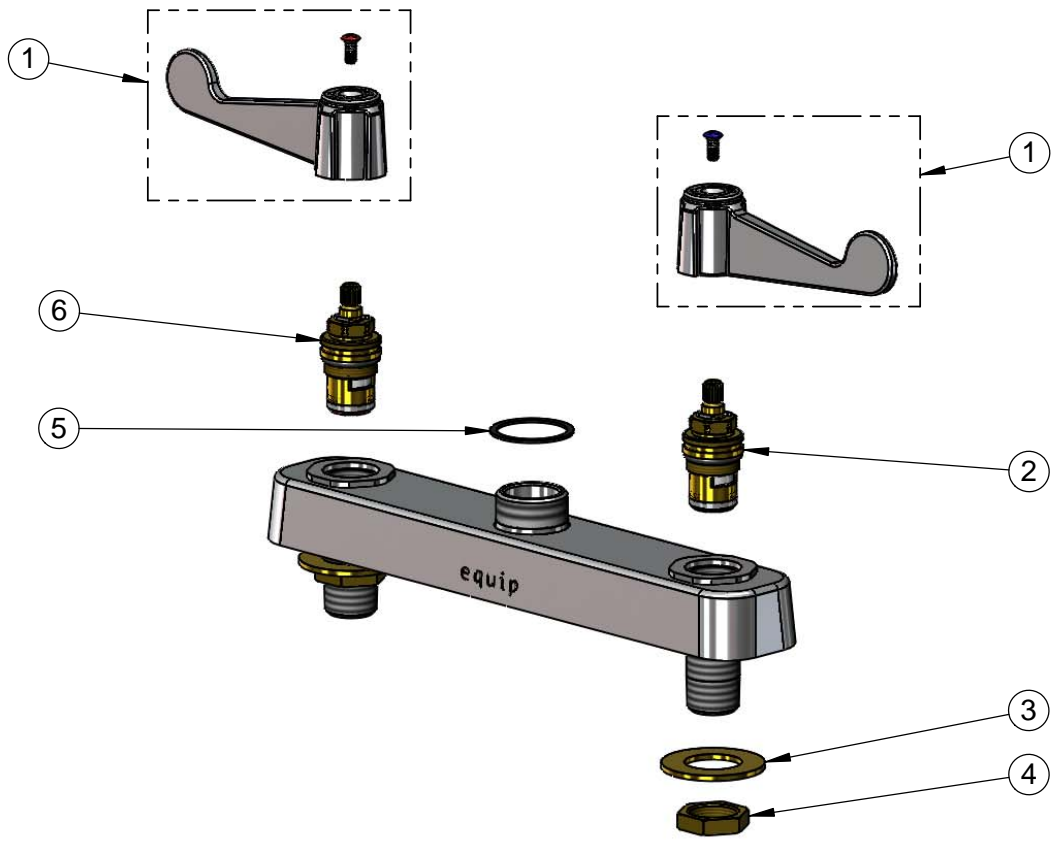

Model Number
5F-8CW00

Product Specifications:
8" Deck Mount Workboard Mixing Faucet Less Nozzle w/ Ceramic Cartridges, equip 4" Wrist Action Handles & 1/2" NPT Male Inlets

Product Compliance:
ASME A112.18.1 / CSA B125.1
NSF 61 - Section 9
NSF 372 (Low Lead Content)
ANSI A117.1 (ADA)

equip
Foodservice
Accessories



2 Saddleback Cove, P.O. Box 1088
Travelers Rest, South Carolina 29690
Phone: 800.891.4808 Fax: 800.868.0084
equip.tsbrass.com