

"ST6R5-SBK" STAINLESS STEEL TOP WORK TABLES

16GA Top w/5" Riser & Stainless Steel Legs & Adjustable Bracing

FEATURES:

- 16GA Stainless Steel Top w/5" Riser & Turndown
- Type 300 Stainless Steel With #4 Polish, Satin Finish
- Top Is Sound Deadened
- Reinforced With 1"x2" Channel Running Entire Length Of Table
- 1-1/2" Stallion Edge On Front Side Edges 90 Degree Bend Down For Table Line-Up
- Stainless Steel Base With Adjustable Bracing
- Adjustable Bullet Feet
- Shipped Knocked-Down, Easy-To-Assemble

SPECIFICATIONS:

- Top: Stainless Steel Tops Are TIG Welded, Exposed Welds Are Polished To Match Adjacent Surface
- Top: 16GA Stainless Steel Type 300 Stainless Steel With #4 Polish, Satin Finish
- Bracing: 1-1/4" Round O.D. 18GA Stainless Steel
- Legs: 1-5/8" Round O.D. 16GA Tubular Stainless Steel
- Gussets: Stainless Steel
- Feet: 1" Adjustable Stainless Bullet Feet

CERTIFICATIONS:



ST6R5-3048SBK

ACCESSORIES

DESCRIPTION

- Drawer
- Drawer Lock
- Casters
- Overshelves
- Sinks
- Pot Rack

"ST6R5-SBK" STAINLESS STEEL TOP WORK TABLES

LENGTH	24" WIDE	WT	WT CAP	30" WIDE	WT	WT CAP	36" WIDE	WT	WT CAP
24"	ST6R5-2424SBK	40	900	ST6R5-3024SBK	44	900	ST6R5-3624SBK	50	900
30"	ST6R5-2430SBK	44	900	ST6R5-3030SBK	48	900	ST6R5-3630SBK	56	900
36"	ST6R5-2436SBK	49	900	ST6R5-3036SBK	54	900	ST6R5-3636SBK	61	900
48"	ST6R5-2448SBK	58	900	ST6R5-3048SBK	65	900	ST6R5-3648SBK	73	900
60"	ST6R5-2460SBK	68	610	ST6R5-3060SBK	75	610	ST6R5-3660SBK	84	610
72"	ST6R5-2472SBK	77	400	ST6R5-3072SBK	85	400	ST6R5-3672SBK	96	400
84"	ST6R5-2484SBK	94	1350	ST6R5-3084SBK	105	1350	ST6R5-3684SBK	121	1350
96"	ST6R5-2496SBK	103	1350	ST6R5-3096SBK	116	1350	ST6R5-3696SBK	133	1350
108"	ST6R5-24108SBK	112	1350	ST6R5-30108SBK	125	1350	ST6R5-36108SBK	142	1350
120"	ST6R5-24120SBK	122	1130	ST6R5-30120SBK	136	1130	ST6R5-36120SBK	154	1130
132"	ST6R5-24132SBK	131	900	ST6R5-30132SBK	146	900	ST6R5-36132SBK	165	900
144"	ST6R5-24144SBK	141	680	ST6R5-30144SBK	158	680	ST6R5-36144SBK	179	680

OVERALL WEIGHT (WT) AND MAX WEIGHT CAPACITY (WT CAP) ARE IN POUNDS (LBS). MAX WEIGHT CAPACITY EVENLY DISTRIBUTED. ALL DIMENSIONS ARE TYPICAL. TOLERANCE +/- .500". JOHN BOOS & CO. RESERVES THE RIGHT TO CHANGE SPECIFICATIONS WITHOUT NOTICE.

DETAILED SPECIFICATIONS

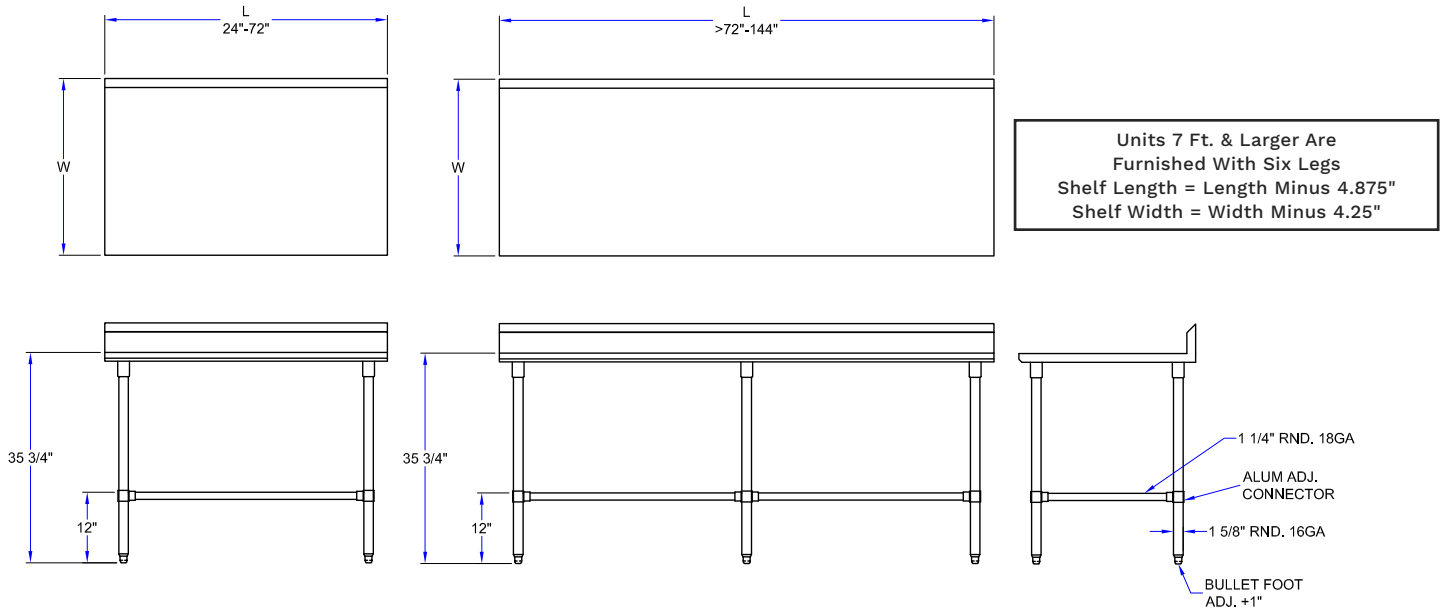

MODEL # STRUCTURE

5 = Ht. Of Riser w/Turndown

R = Top w/Riser

6 = 16GA Work Surface

ST = Stainless Steel Top

24 = Width Of Work Surface

30 = Length Of Work Surface

SB = Stainless Legs & Bracing

K = Ships Knocked Down

ST6R5-2430SBK

"ST6R5-SBK" STAINLESS STEEL TOP WORK TABLES

LENGTH	24" WIDE	WT	WT CAP	30" WIDE	WT	WT CAP	36" WIDE	WT	WT CAP
24"	ST6R5-2424SBK	40	900	ST6R5-3024SBK	44	900	ST6R5-3624SBK	50	900
30"	ST6R5-2430SBK	44	900	ST6R5-3030SBK	48	900	ST6R5-3630SBK	56	900
36"	ST6R5-2436SBK	49	900	ST6R5-3036SBK	54	900	ST6R5-3636SBK	61	900
48"	ST6R5-2448SBK	58	900	ST6R5-3048SBK	65	900	ST6R5-3648SBK	73	900
60"	ST6R5-2460SBK	68	610	ST6R5-3060SBK	75	610	ST6R5-3660SBK	84	610
72"	ST6R5-2472SBK	77	400	ST6R5-3072SBK	85	400	ST6R5-3672SBK	96	400
84"	ST6R5-2484SBK	94	1350	ST6R5-3084SBK	105	1350	ST6R5-3684SBK	121	1350
96"	ST6R5-2496SBK	103	1350	ST6R5-3096SBK	116	1350	ST6R5-3696SBK	133	1350
108"	ST6R5-24108SBK	112	1350	ST6R5-30108SBK	125	1350	ST6R5-36108SBK	142	1350
120"	ST6R5-24120SBK	122	1130	ST6R5-30120SBK	136	1130	ST6R5-36120SBK	154	1130
132"	ST6R5-24132SBK	131	900	ST6R5-30132SBK	146	900	ST6R5-36132SBK	165	900
144"	ST6R5-24144SBK	141	680	ST6R5-30144SBK	158	680	ST6R5-36144SBK	179	680

OVERALL WEIGHT (WT) AND MAX WEIGHT CAPACITY (WT CAP) ARE IN POUNDS (LBS). MAX WEIGHT CAPACITY EVENLY DISTRIBUTED.
ALL DIMENSIONS ARE TYPICAL. TOLERANCE +/- .500". JOHN BOOS & CO. RESERVES THE RIGHT TO CHANGE SPECIFICATIONS WITHOUT NOTICE.