

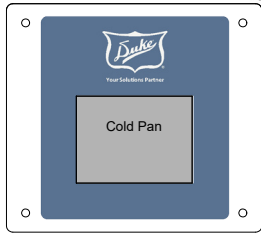

Your Solutions Partner

Specifications

F.O.B. Sedalia, Missouri 65301

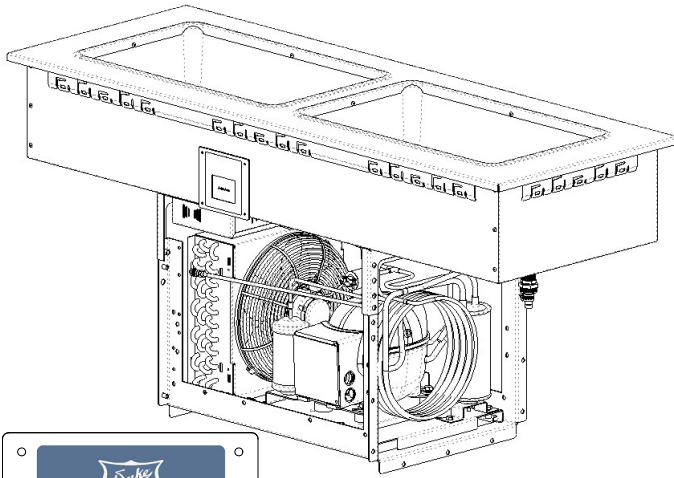

Model FCP2-SL Shown

OPTIONS:

- No-Drain (required for California)
- Basic Control mounted to side of compressor cage

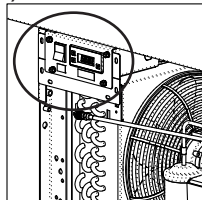

Agency Listings:



DUKE MANUFACTURING CO.

2305 N. Broadway
 St. Louis, MO 63102
 800.735.3853 Toll Free
 314.231.5074 Fax
 www.dukemfg.com

SS-1250 Flush Mount Cold Pan-Slimline

Approval Stamp(s):

PRODUCT INFORMATION:

PROJECT: _____

ITEM: _____

QUANTITY: _____

MODEL:

Drop In Flush Mount Cold Pan-Slimline

- FCP2-SL Drop In, Flush Cold Pan 2-section with drain
- FCP3-SL Drop In, Flush Cold Pan 3-section with drain

BODY:

- Top mount with flush mount pans
- Top – heavy gauge 300 series stainless steel
- Stamped top wells available for standard wells
- Exterior outer body - paint grip steel, one body housing all wells
- Standard 22" horizontal spacing for wells
- High density CFC free polyurethane foam insulation (zero global warming potential (GWP), & zero ozone depletion potential (ODP))

FEATURES:

- Standard food pan - 12 x 20
- Will also accommodate 1/2 and 1/3rd size pans
- Accepts up to 6" deep full size food pans
- Food pans flush with top (not recessed)
- Standard - drain for each well, (manifolded to one location)
- Slimline – 2-3 Sections
- Refrigerant – Environmentally safe R448a
- Individual coils for each well
- TXV control for optimal performance
- Open suspended compressor compartment
- Compressor slides out for easy service
- 6 Foot Power Cord

CONTROLS

- Standard intuitive, easy to use touch screen control
- Easily adjusted presets LOW/MED/HIGH (on touch screen control only)
- Built in WIFI and Bluetooth for future connectivity.
- On/Off Switch

Specification subject to change

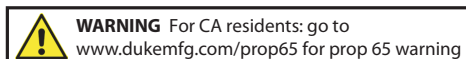

Drop In Flush Cold Pan - Slimline

Catalog No. Cold Pan

A.I.A. File No. 35-C-13

REV C 05/16/2024

Drop In Flush Mount Cold Pan - Slimline

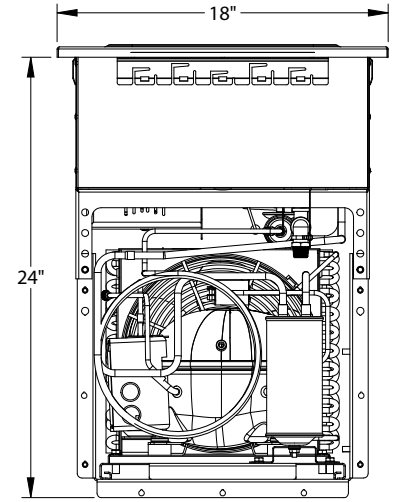
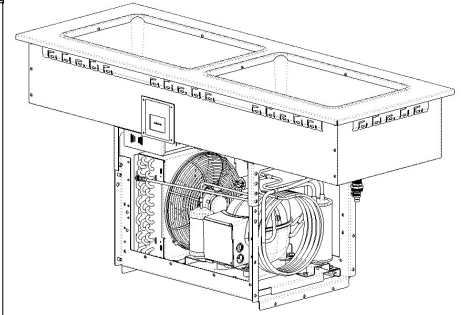
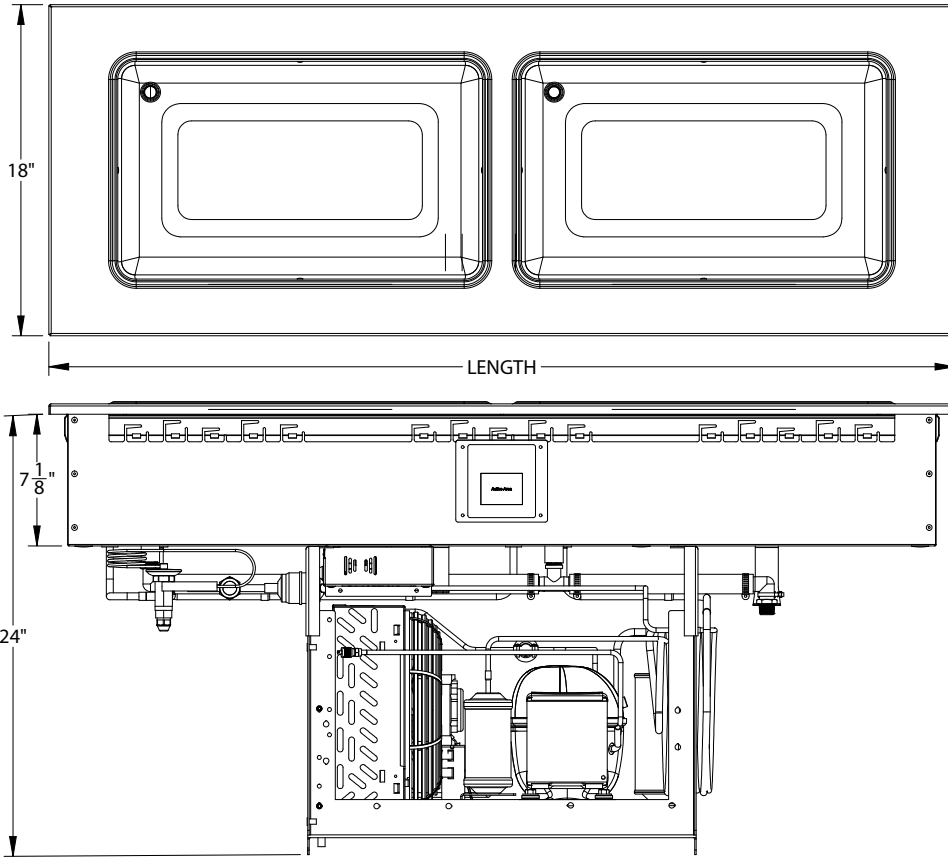

FCP2 Drop In, Flush Cold Pan
2-section With Drains - Shown

ELECTRICAL SPECIFICATIONS:

*If using optional electric condensate evaporator add 300 Watts, 2.6 Amps"

Model	120 Volt - HZ 60		
	Watts*	Amps*	NEMA
FCP2-SL	432	3.7	5-15
FCP3-SL	576	4.9	5-15

Control Specifications

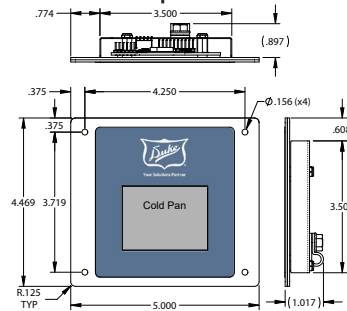

Control Cutout

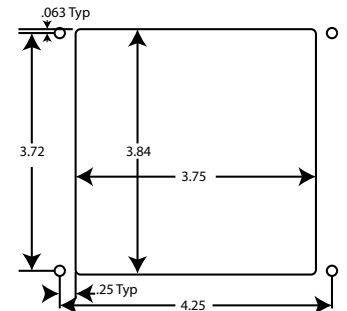

DIMENSIONS:

Freight Class: 100

Model	Height		Length		Width		Counter Top Cutouts		Cube ft. crated	Crated Ship Weight	
	in.	cm	in.	cm	in.	cm	Length	Width		lbs.	kg
FCP2-SL	24.0	60.96	49.38	125.43	18.00	45.72	47.75	16.75	20.2	165	74.84
FCP3-SL	24.0	60.96	71.38	181.31	18.00	45.72	69.75	16.75	28.4	225	102.06

This product may be covered by one or more patents or pending patent applications. For more details, see: www.dukemfg.com/patents



Duke Manufacturing Co.
2305 N. Broadway
St. Louis, MO 63102

Phone: 314-231-1130
Toll Free: 1-800-735-3853
Fax: 314-231-5074

www.dukemfg.com