

MADE IN GREECE



Models:
1510 / 500

Standard Features

- High Temp with Booster
- Electronic Circuit with 3 Washing Programs
- Standard Peristaltic Rinse Aid & Detergent Pump
- Self Cleaning function
- Malfunction Self-Diagnose
- Standard Draining Pump
- Thermo-protector feature

1510

- Capable of washing GN 1/1 pan
- Stainless-Steel Washing Nozzles
- Tank & Boiler Thermometer

500

- Steady Upper Washing Nozzles for more efficiency
- Stainless-Steel Wash & Rinse Group
- Tank & Boiler Thermometer



1-year parts and labor warranty (US Only)

SPECIFICATIONS		
	1510	500
Motor Power (Hp)	1 1/2	3/4
Type	Door Universal	Undercounter Front Loading
Basket Dimension	20" x 20"	20" x 20"
Door Clearance	15.75"	14.17"
Length of Cycle	60/120/180 sec**	60/120/180 sec**
Baskets/Hour	30	20/30/60 **
Glasses/Hour	1470	735/1470/2205
Dishes/Hour	540	270/540/810
Tank Capacity	15 Gal (56.8 L)	9.2 Gal (35 L)
Boiler Capacity	2 Gal (7.6 L)	1.6 Gal (6.1 L)
Power Supply	220V/60HZ/1ph	220V/60HZ/1ph
Amps	43.4	33.3
Plug / Connection	Wire - No plug	
Product Dim. (WxDxH) DOOR CLOSED	29.5" x 34.6" x 54.7"	22.4" x 23.6" x 32.7"
Product Dim. (WxDxH) DOOR OPENED	29.5" x 34.6" x 72"	22.4" x 37.8" x 32.7"
Product Weight (lbs)	291	122
Shipping Dim. (WxDxH)	30" x 36" x 61"	24" x 28" x 40"
Shipping Weight (lbs)	327	133

**Depends on Program Selection

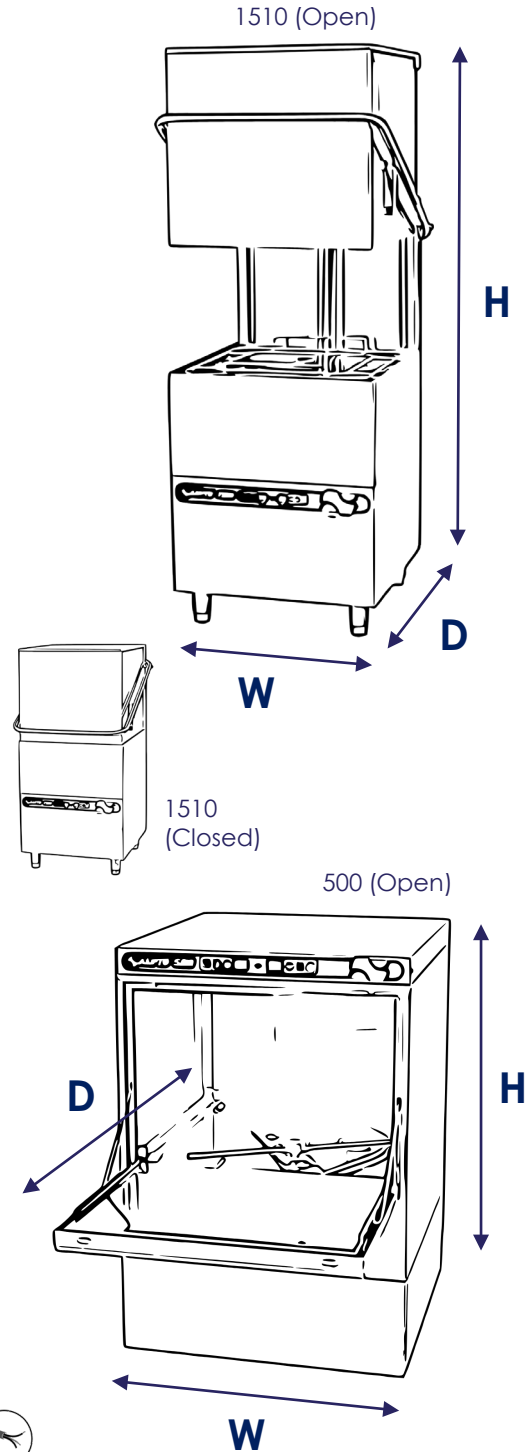

Notes:

- Properly clean and dry after daily use to ensure best performance and equipment longevity.



Wired
No Plug

AMPTO is continuously improving products. Specifications are subject to change without notice.