

SSSCTS

Mobile Tray and Silver Stands

Short Form Specifications

Exterior body is constructed of 18-gauge stainless steel side panels and 14-gauge galvanized bottom. All exterior side panels are reinforced with overlapping corners and are welded in place. All body cutouts are reinforced with 14-gauge galvanized channel supports.

Exterior top is constructed of 14-gauge stainless steel, welded, ground and polished into one integral unit. Top is fabricated with square exterior corners.

Casters unit is mounted on 5" (12.7cm) diameter swivel casters with non-marking polyolefin tires and plate brakes. Overall height of caster assembly is 6" (15.2cm).

Two year parts and labor warranty

Optional Accessories & Modifications

- F)** Line-up interlock device
- ST)** Stainless steel trim strips
- SW)** Silverware cutouts with stainless steel bins
- V)** 6" (15.2cm) high adjustable stainless steel legs in lieu of casters
- X)** Laminate exterior panels in lieu of stainless steel exterior panels

SCTS: Mobile Tray and Silver Stands



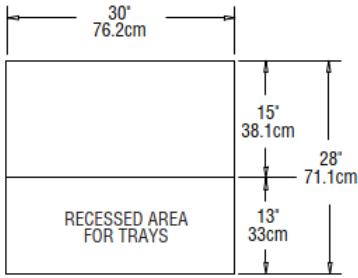

**PLAN VIEW
SCTS-28**

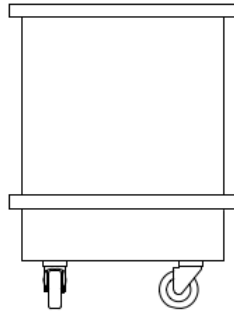

**ELEVATION VIEW
SCTS-28**

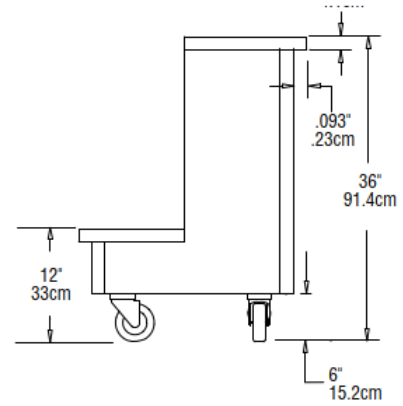

**END VIEW
SCTS-28**

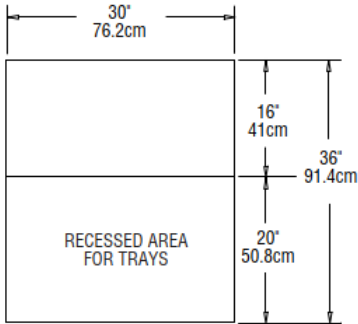

**PLAN VIEW
SCTS-36**

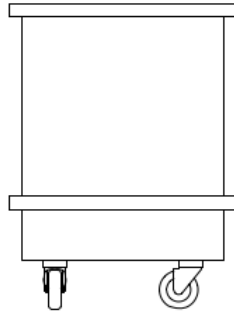

**ELEVATION VIEW
SCTS-36**

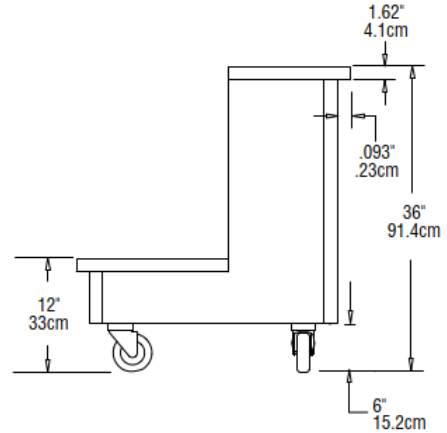

**END VIEW
SCTS-36**

Mechanical Data—Standard Unit

MODEL NUMBER	SHIP WEIGHT
SCTS-28	150 lbs/68 kg
SCTS-36	192 lbs/87kg

Delfield reserves the right to make changes to the design or specifications without prior notice.