

Project: _____	AIA# _____
Item #: _____ Qty: _____	SIS# _____
Model #: _____	

Corner Inside Wedge Fillerboards



Intertek
4004503
Conforms to ANSI/NSF STD 2

C-CIW	C-CIWB-5, C-CIWB-10, C-CIWB-15, C-CIWB-20, C-CIWB-25, C-CIWB-30, C-CIWB-45
--------------	--

Standard Features

- All stainless steel
- Designed to mount between two adjacent pieces of Choice underbar equipment
- Flat work surface excluding 45° model which features a corrugated work surface

Specifications

Materials

- 20 gauge stainless steel

Drain

- 1-1/2" I.P.S. Threaded drain will fit Dearborn part #8033 slipnut and part #W-573P washer (C-CIWB-45 model only)

Dimensional Information

PLAN VIEWS

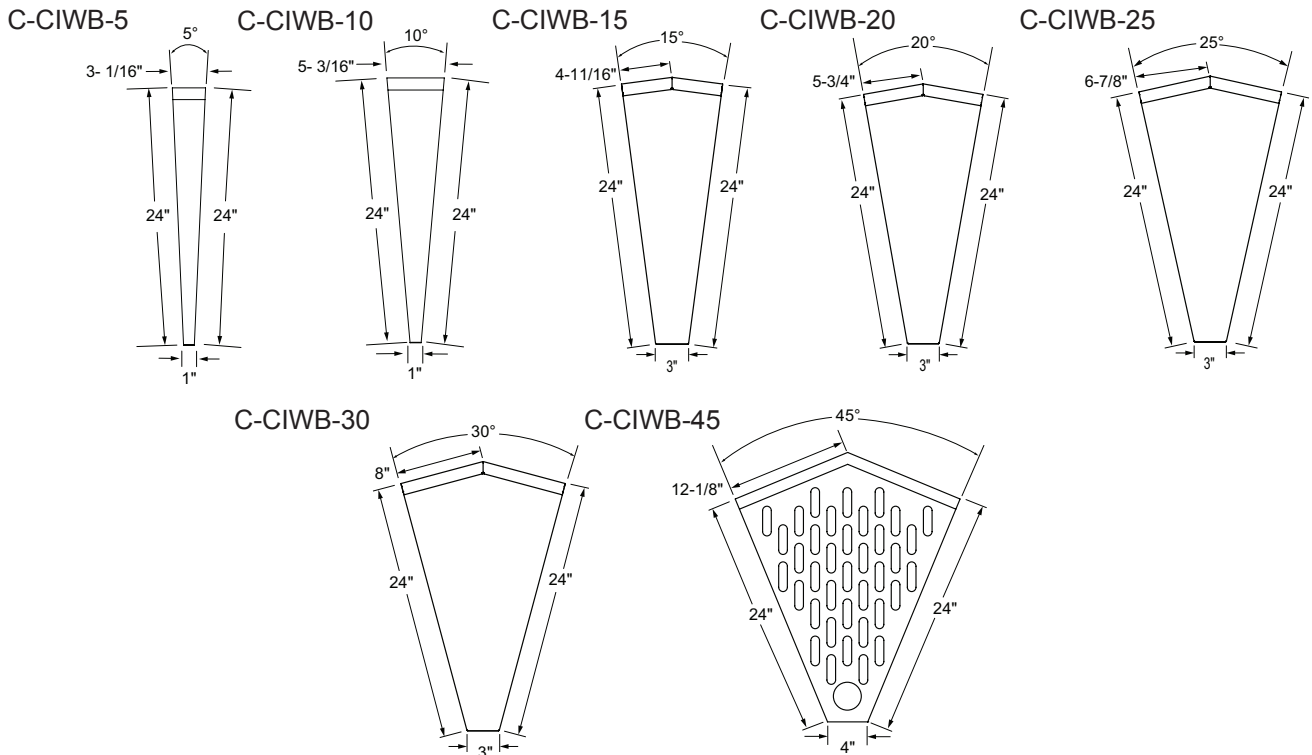

To view cleaning and care instructions, please visit: https://glastender.com/PDF/F-423-011_ss_clean_care.pdf

<p>Glastender, Inc. • 5400 North Michigan Road • Saginaw, MI • 48604-9780 989.752.4275 • 800.748.0423 • Fax 989.752.4444 https://glastender.com</p>	<p>Approval/Notes:</p>
<p>Specifications subject to change without notice. For current specifications please visit our website.</p>	