

"UFBLS" BUDGET STAINLESS STEEL TOP WORK TABLES

18GA Top w/Stainless Steel Legs & Adjustable Undershelf - 1½" Riser

FEATURES:

- 18GA Stainless Steel Top w/1-1/2" Rear Riser
- Type 430 Stainless Steel With Satin Finish
- Top Is Sound Deadened
- Reinforced With 1"x2" Channel Running Entire Length Of Table
- 1-1/2" Stallion Edge On Front And Rear With Side Edges 90 Degree Bend Down For Table Line-Up
- Stainless Steel Base And Adjustable Undershelf
- Shipped Knocked-Down, Easy-To-Assemble
-

SPECIFICATIONS:

- Top: Stainless Steel Tops Are TIG Welded, Exposed Welds Are Polished To Match Adjacent Surface
- Top: 18GA Stainless Steel Type 430 Stainless Steel With Satin Finish
- Shelf: 18GA Stainless Steel
- Legs: 1-5/8" Round O.D. 16GA Tubular Stainless Steel
- Gussets: Stainless Steel
- Feet: 1" Adjustable Plastic Bullet Feet



UFBLS4830

CERTIFICATIONS:



"UFBLS" BUDGET STAINLESS STEEL TOP WORK TABLES

LENGTH	18" WIDE	WT (LBS)	24" WIDE	WT (LBS)	30" WIDE	WT (LBS)
24"	UFBLS2418	35	UFBLS2424	40	-	-
30"	UFBLS3018	38	UFBLS3024	45	UFBLS3030	50
36"	UFBLS3618	41	UFBLS3624	50	UFBLS3630	56
48"	UFBLS4818	44	UFBLS4824	62	UFBLS4830	69
60"	UFBLS6018	47	UFBLS6024	71	UFBLS6030	82
72"	UFBLS7218	50	UFBLS7224	83	UFBLS7230	94
96"	UFBLS9618	56	UFBLS9624	111	UFBLS9630	128

ALL DIMENSIONS ARE TYPICAL. TOLERANCE +/- .500". JOHN BOOS & CO. RESERVES THE RIGHT TO CHANGE SPECIFICATIONS WITHOUT NOTICE.

DETAILED SPECIFICATIONS

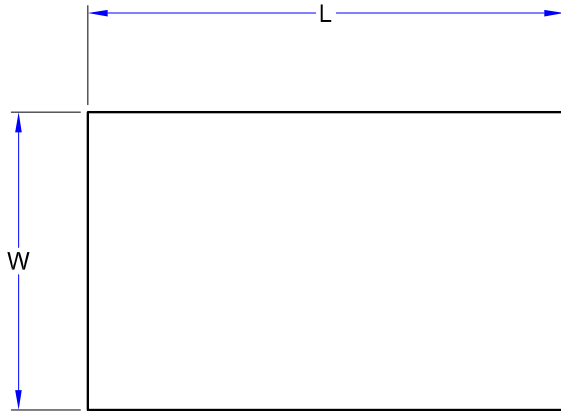

Units 7 Ft. & Larger Are
Furnished With Six Legs
Shelf Length = Length Minus 4.875"
Shelf Width = Width Minus 4.25"

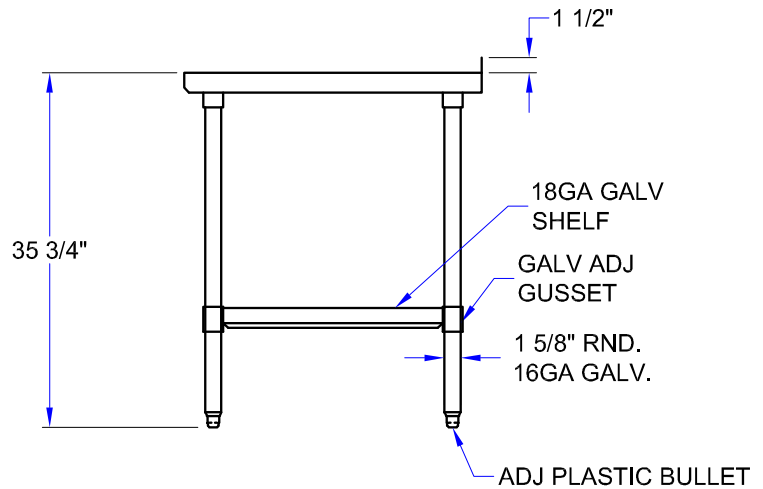
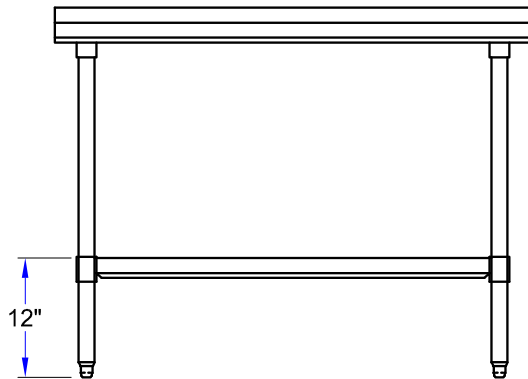

"UFBLs" BUDGET STAINLESS STEEL TOP WORK TABLES

LENGTH	18" WIDE	WT (LBS)	24" WIDE	WT (LBS)	30" WIDE	WT (LBS)
24"	UFBLS2418	35	UFBLS2424	40	-	-
30"	UFBLS3018	38	UFBLS3024	45	UFBLS3030	50
36"	UFBLS3618	41	UFBLS3624	50	UFBLS3630	56
48"	UFBLS4818	44	UFBLS4824	62	UFBLS4830	69
60"	UFBLS6018	47	UFBLS6024	71	UFBLS6030	82
72"	UFBLS7218	50	UFBLS7224	83	UFBLS7230	94
96"	UFBLS9618	56	UFBLS9624	111	UFBLS9630	128

ALL DIMENSIONS ARE TYPICAL. TOLERANCE +/- .500". JOHN BOOS & CO. RESERVES THE RIGHT TO CHANGE SPECIFICATIONS WITHOUT NOTICE.