



U-Star's Narrow Depth Back Bar Coolers are a great way to merchandise and store beer, soda and other beverages in your bar or restaurant. Constructed with an all stainless steel countertop, interior floor and walls and features LED lighting and adjustable shelves. The 24" narrow depth is ideal for establishments with a smaller work area. These units are available in both glass and solid swing door models. These models are ETL Listed, ETL Sanitation and backed by a 1 year warranty on parts and labor and a 5 year warranty on the compressor.

Product Features

- 304 stainless steel top, interior walls and floor
- Durable black steel exterior
- Environmentally-friendly R290 refrigerant
- Side mounted compressor
- Foamed-in-place polyurethane high density cell insulation throughout the entire cabinet
- Plastic coated wire shelves
- Automatic defrosting
- 24" narrow depth is great for areas with limited bar space

Specifications



Model Number	USBB-4824G	USBB-4824	USBB-6024G	USBB-6024	USBB-7224G	USBB-7224
Type	Glass Door	Solid Door	Glass Door	Solid Door	Glass Door	Solid Door
Doors	2	2	2	2	3	3
Shelves	4	4	4	4	6	6
Net Volume (Cu. Ft.)	11.8 Cu. ft.	11.8 Cu. ft.	15.8 Cu. ft.	15.8 Cu. ft.	19.6 Cu. ft.	19.6 Cu. ft.
Overall Dimensions (in)	48" x 24.5" x 35.8"	48" x 24.5" x 35.8"	60.2" x 24.5" x 35.8"	60.2" x 24.5" x 35.8"	72.8" x 24.5" x 35.8"	72.8" x 24.5" x 35.8"
Interior Dimensions (in)	36" x 18.5" x 29"	36" x 18.5" x 29"	48" x 18.5" x 29"	48" x 18.5" x 29"	60" x 18.5" x 29"	60" x 18.5" x 29"
Refrigerant	R290	R290	R290	R290	R290	R290
Horsepower	1/5	1/5	1/5	1/5	1/4	1/4
Voltage/Hertz/Phase	115/60/1	115/60/1	115/60/1	115/60/1	115/60/1	115/60/1
Amps	2.88	2.88	2.88	2.88	3.96	3.96
Net Weight (lbs)	216 lbs	187 lbs	260 lbs	247 lbs	311 lbs	309 lbs
Gross Weight (lbs)	260 lbs	231 lbs	304 lbs	291 lbs	355 lbs	353 lbs
Shipping Dimensions (in)	51" x 27.5" x 41"	51" x 27.5" x 41"	63" x 27.5" x 41"	63" x 27.5" x 41"	75" x 27.5" x 41"	75" x 27.5" x 41"

Capacity

Model Number	USBB-4824G	USBB-4824	USBB-6024G	USBB-6024	USBB-7224G	USBB-7224
Kegs (Half Barrels)	2	2	2	2	3	3
12 oz. Cans	48 6-pks	48 6-pks	72 6-pks	72 6-pks	76 6-pks	76 6-pks

Plan Views

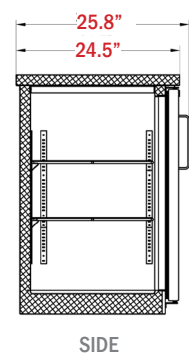
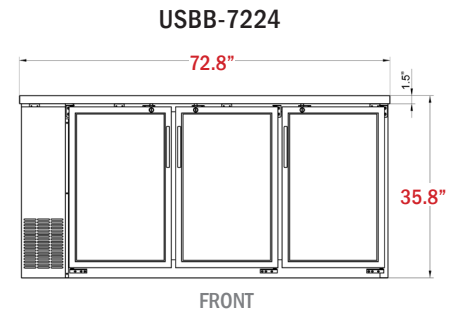
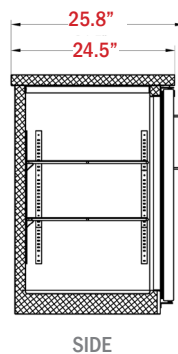
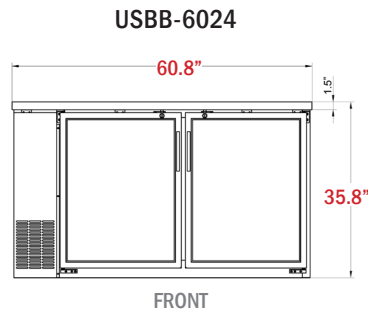
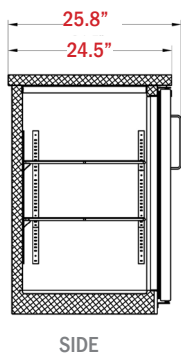
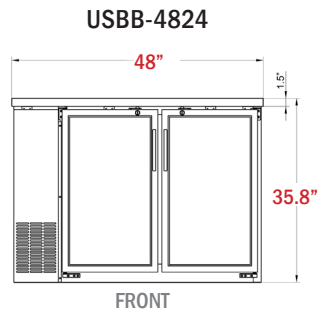

Features

Cooling System

- Refrigeration units use environmentally friendly R290 refrigerant
- Balanced refrigeration system helps to maintain a temperature range of 33 °F–41 °F
- Condensing unit is located behind front grill and slides out for easy cleaning

Electrical Control

- 115V/60 connection for all models
- 7' power cord with NEMA 5-15 plug from the back of the unit



Cabinet Construction

- Exterior is constructed of a durable black vinyl front and sides with an aluminum back with an all stainless steel countertop
- Interior is constructed of all stainless steel floor and walls
- The cabinet is insulated throughout with a foamed-in-place high density cell polyurethane insulation
- 24" Narrow depth is ideal for areas with limited workspace

Doors

- Swing door style available in either double pane thermal glass or durable solid black vinyl doors
- 12" long recessed handles
- Postive seal doors
- Door locks come standard on all models

Shelving

- Heavy duty PVC coated wire shelves are adjustable
- Aluminum shelf support system that are adjustable for every 1/2"

Model Features

- Interior LED lighting for greater visibility throughout the cabinet