



# FlexiShield® Food Shields

Double Tier, Bottom Tier Full Glass Front, Second Tier Sneeze Guard

Project \_\_\_\_\_  
 Item \_\_\_\_\_  
 Quantity \_\_\_\_\_  
 CSI Section 11400  
 Approved \_\_\_\_\_  
 Date \_\_\_\_\_

FlexiShield® Food Shields: Double Tier, Bottom Tier Full Glass Front, Second Tier Sneeze Guard

## Models

- DCFSGH Available in 1" increments up to 120" long

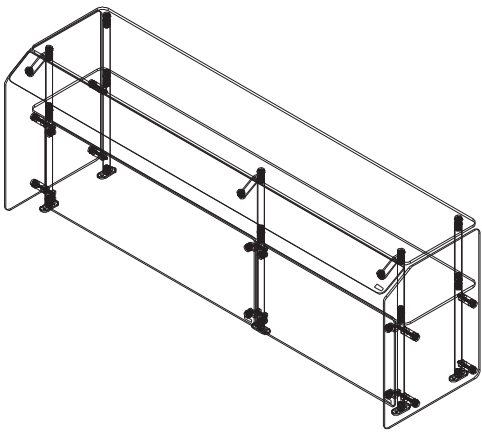

DCFSGH

## Standard Features

- Mostly glass display allows you to see product from every angle
- 1" stainless steel legs
- Meets 2011 NSF requirements
- Flange mounted foot makes installation easy
- Comes fully assembled from the factory
- Standard end glass
- One year parts and labor standard warranty

## Options & Accessories

- Radiant heat lamp\*
  - Stainless steel shelf
  - Black powder coat
  - Fluorescent light\*
  - LED lights\*
  - Narrow halogen heatlamp\*
  - Narrow halogen heatlamp with xenon lights\*
  - Narrow xenon display lights\*
- \* Inclusion of this option will alter the electrical specifications of the unit

## Specifications

1" stainless steel legs and flanged feet are standard. Models 52.50" (133cm) in length and less will have two sets of legs. Models greater than 52.50" (133cm) in length will have three sets of legs. Top glass is 3/8" tempered. End glass is 1/4" tempered. Front glass is 1/4" tempered. Chrome plated hardware standard.



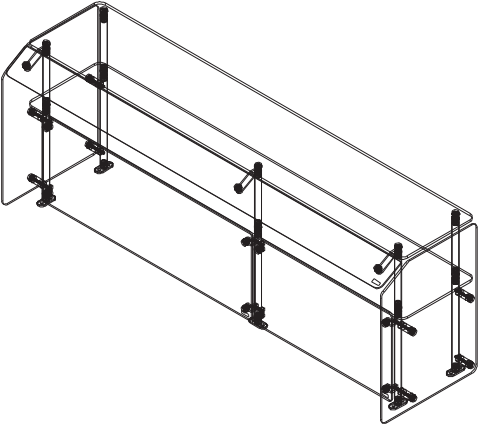

Models 52.50" (133cm) in length and less will have two sets of legs.  
Models greater than 52.50" (133cm) in length will have three sets of legs.

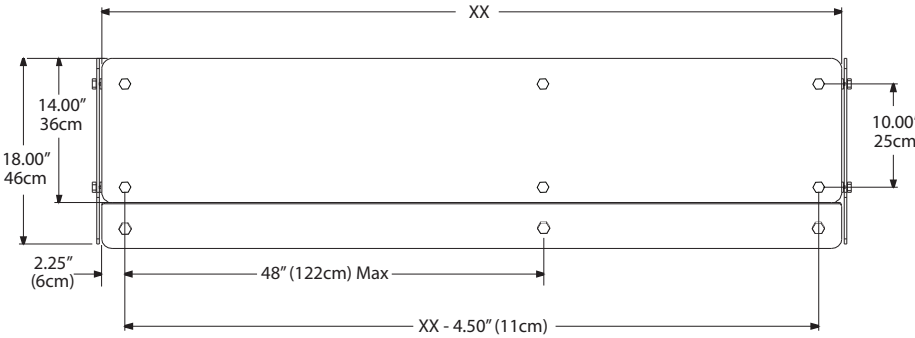

**Plan View**

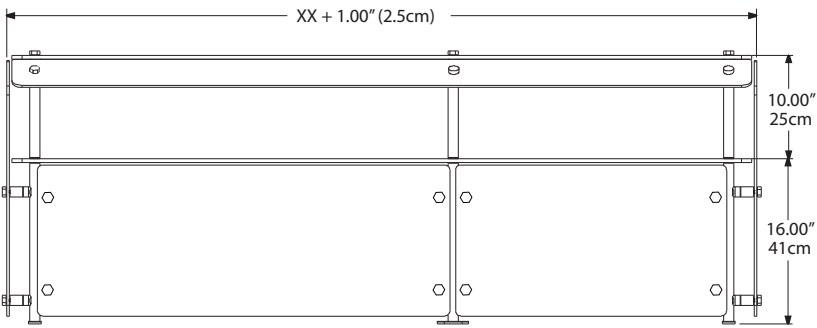

**Elevation View**

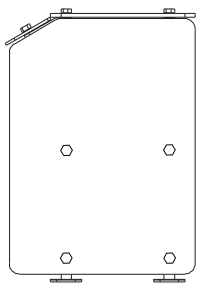

**Side View**

Specifications				
Model	L	W	H	Ship Weight
DCFSGH	XX	18.00" (46cm)	26.00" (66cm)	Contact factory

Delfield reserves the right to make changes to the design or specifications without prior notice.