



C-DW-15L



Intertek
4004503
Conforms to ANSI/NSF STD 2

Project: _____	AIA# _____
Item #: _____ Qty: _____	SIS# _____
Model #: _____	

Dry Waste Chutes

Patent Pending†

C-DW C-DW-12, C-DW-14-C†, C-DW-15L, C-DW-15R

Standard Features

- All stainless steel
- Lift-off top for trash receptacle removal and cleaning
- 30" high work surface
- C-DW-12 has no legs; must be bridge mounted between underbar
- C-DW-14-C† is free standing with two leg sets and hinged access door
- C-DW-15L and C-DW-15R have one leg set; must be side mounted to underbar

Configurable Options

C-LSDW Left side splash for C-DW-14-C†

C-RSDW Right side splash C-DW-14-C†

Accessory

03000497 Rubbermaid Slim Jim® trash receptacle

Specifications

Legs (C-DW-12 excluded)

- 1-5/8" diameter, 16 gauge stainless steel
- Stainless steel bullet feet

Materials

- 20 gauge stainless steel parts include: all parts unless otherwise noted
- 18 gauge stainless steel parts include: top and bottom mounting channels

To view cleaning and care instructions, please visit: https://glastender.com/PDF/F-423-011_ss_clean_care.pdf

<p>Glastender, Inc. • 5400 North Michigan Road • Saginaw, MI • 48604-9780 989.752.4275 • 800.748.0423 • Fax 989.752.4444 https://glastender.com</p>	Approval/Notes:
Specifications subject to change without notice. For current specifications please visit our website.	

Choice Dry Waste Chutes

Dimensional Information

C-DW-12

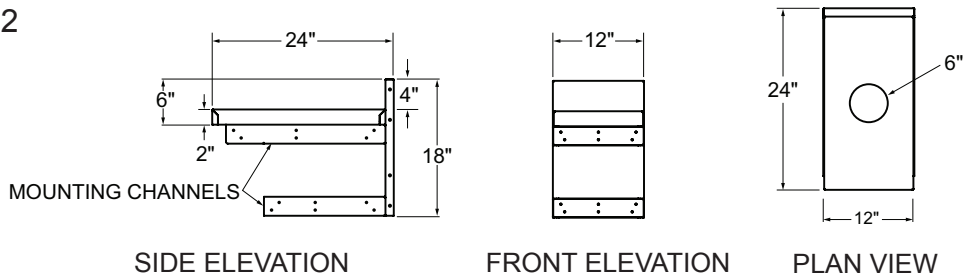

C-DW-14-C†

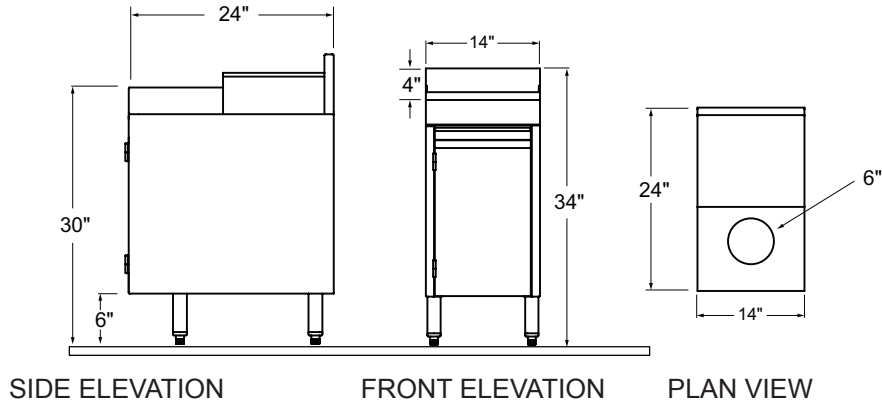

C-DW-15L

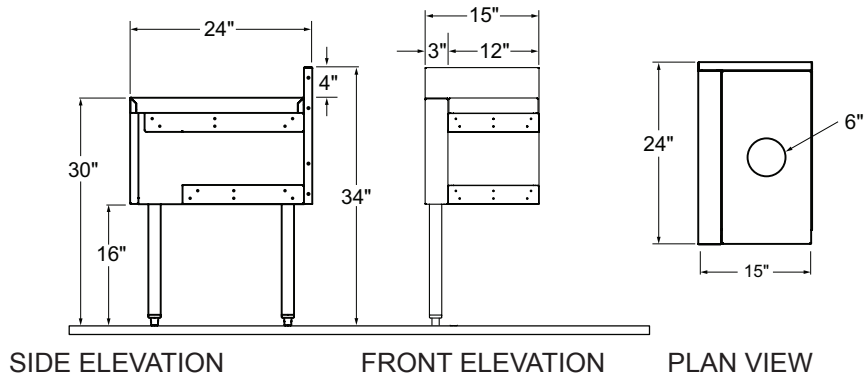

C-DW-15R

