



# EVERPURE® OCS<sup>2</sup> FILTER CARTRIDGE

DELIVERS PREMIUM QUALITY WATER FOR OCS APPLICATIONS

OCS<sup>2</sup> Replacement Cartridge: EV9618-02



## APPLICATIONS

Office Coffee Service (OCS)  
Low-Flow, Low-Volume Brewers

## FEATURES • BENEFITS

Provides clear, fresh, premium quality ingredient water for consistently great tasting coffee and beverages

Sanitary cartridge replacement is simple, quick and clean; internal filter parts are never exposed to handling or contamination

Everpure's unique filter blend using activated carbon reduces chlorine taste & odor and other offensive contaminants

Saves energy by reducing scale buildup;\* proportioned scale inhibitor feed dramatically prevents limescale from forming in brewing equipment

Exclusive precoat filtration provides superior chlorine taste & odor reduction and micro-filters dirt and particles as small as 0.5 micron in size by mechanical means

Proprietary Micro-Pure® II filtration media effectively inhibits the growth of bacteria on the filter media that can decrease product life

Reduces cysts such as *Cryptosporidium* and *Giardia* by mechanical means

\*As tested by Pentair

## INSTALLATION TIPS

Never use saddle valve for connection.

Use 3/8" water line.

Install vertically with cartridge hanging down.

Allow 2 1/2" (6.35 cm) clearance below the cartridge for easy cartridge replacement.

Flush OCS<sup>2</sup> cartridge by running water through system for three (3) minutes at full flow.

## OPERATION TIPS

Replace cartridge when flow rate becomes inconveniently slow or before rated capacity is reached. It is recommended to replace cartridge at least once per year.

Change cartridges when capacity is reached or when pressure falls below 10 psi (0.7 bar).

Service flow rate must not exceed 0.5 gpm (1.9 Lpm).

Always flush the filter cartridge at time of installation and cartridge change.

## SIZING

Service Flow Rate: Maximum 0.5 gpm (1.9 Lpm)

Rated Capacity: 1,500 gallons (5,678 L) or 3,000 pots

# EVERPURE® OCS<sup>2</sup> FILTER CARTRIDGE

## EV9618-02

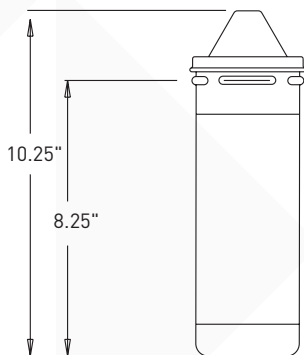

### SPECIFICATIONS

#### Rated Capacity

1,500 gallons (5,678 L) or 3,000 pots

#### Service Flow Rate

Maximum 0.5 gpm (1.9 Lpm)

#### Pressure Requirements

10 - 125 psi (0.7 - 8.6 bar), non-shock

#### Temperature Limits

35 - 100°F (2 - 38°C)

#### Overall Dimensions

10.25" L x 3.25" D (26.0 cm x 8.2 cm)



System Tested and Certified by NSF International against NSF/ANSI Standard 42 and 53 for the reduction of:

STANDARD NO. 42 —  
AESTHETIC EFFECTS  
Bacteriostatic Effects

Chemical Reduction  
Taste and Odor  
Chlorine

Mechanical Filtration  
Nominal Particulate Class I

STANDARD NO. 53 —  
HEALTH EFFECTS

Mechanical Filtration  
Cyst  
Asbestos

EPA No. 002623-IL-002

The contaminants or other substances removed or reduced by this drinking water system are not necessarily in your water. Do not use with water that is microbiologically unsafe or of unknown quality without adequate disinfection before or after the system. Systems certified for cyst reduction may be used with disinfected water that may contain filterable cysts.

### WARRANTY

Everpure water treatment systems by Pentair® (excluding replaceable elements) are covered by a limited warranty against defects in material and workmanship for a period of five years after date of purchase. Everpure replaceable elements (filter cartridges and water treatment cartridges) are covered by a limited warranty against defects in material and workmanship for a period of one year after date of purchase. See printed warranty for details. Pentair will provide a copy of the warranty upon request.



#### WATER FILTRATION

EVERPURE-SHURFLO WORLD HEADQUARTERS, 1040 MUIRFIELD DRIVE, HANOVER PARK, IL 60133 USA • FOODSERVICE.PENTAIR.COM  
800.942.1153 (US ONLY) • 630.307.3000 MAIN • 630.307.3030 FAX • CSEVERPURE@PENTAIR.COM EMAIL

EVERPURE-SHURFLO AUSTRALIA, 1-21 MONASH DRIVE, DANDENONG SOUTH, VIC 3175 AUSTRALIA  
011.1300 576 190 TEL • 011.61.39.562.7237 FAX • AU.EVERPURE@PENTAIR.COM EMAIL

EVERPURE-SHURFLO CHINA, 21F CLOUD 9 PLAZA, NO 1118, SHANGHAI, 200052, CHINA  
86.21.3211.4588 TEL • 86.21.3211.4580 FAX • CHINA.WATER@PENTAIR.COM EMAIL

EVERPURE-SHURFLO INDIA, GREEN BOULEVARD, B-9/A, 7TH FLOOR - TOWER B SECTOR 62, NOIDA - 201301  
91.120.419.9444 TEL • 91.120.419.9400 FAX • INDIACUSTOMER@PENTAIR.COM EMAIL

EVERPURE-SHURFLO EUROPE, PENTAIR WATER BELGIUM BVBA, INDUSTRIEPARK WOLFSTEE, TOEKOMSTLAAN 30, B-2200 HERENTALS, BELGIUM  
+32.(0).14.283.504 TEL • +32.(0).14.283.505 FAX • SALES@EVERPURE-EUROPE.COM EMAIL

EVERPURE-SHURFLO JAPAN INC., HASHIMOTO MN BLDG. 7F, 3-25-1 HASHIMOTO, MIDORI-KU, SAGAMIHARA-SHI KANAGAWA 252-0143, JAPAN  
81.(0)42.775.3011 TEL • 81.(0)42.775.3015 FAX • INFO@EVERPURE.CO.JP EMAIL

EVERPURE-SHURFLO SOUTHEAST ASIA, 390 HAVELOCK ROAD, #04-01 KING'S CENTRE, SINGAPORE 169662  
65.6768.5800 TEL • 65.6737.5149 FAX • CSEVERPURE@PENTAIR.COM EMAIL

Pentair trademarks and logos are owned by Pentair plc or its affiliates. Third party registered and unregistered trademarks and logos are property of their respective owners. Because we are continuously improving our products and services, Pentair reserves the right to change specifications without prior notice. Pentair is an equal opportunity employer.