

Dutchess

Bakers' Machinery Company, Inc.

A subsidiary of Superior-Lidgerwood-Mundy Corp

Item No.

Model DUT/M140-W

**140 Quart Floor Model Mixer
w/Electric Bowl Lift**



Standard Features:

- ◆ Heavy Duty 6HP Motor,
- ◆ 208/240/60/3
- ◆ # 12 Attachment Hub
- ◆ 1/2 HP Lift Motor with Gear Reduction
- ◆ Gear Driven Transmission
- ◆ 4-Speed with 30-Minute Timer w/Auto Shut-off
- ◆ Safety Bowl Guard
- ◆ Bowl Lift Safety
- ◆ Electric Bowl Lift
- ◆ Dough Hook
- ◆ Wire Whip
- ◆ Beater Paddle
- ◆ Stainless Steel Bowl & Dolly for easy Transport
- ◆ Bowl Locking Handles
- ◆ 3-yr Limited Parts Warranty
- ◆ 1 Year Full Parts & Labor Warranty



Dutchess Bakers' Machinery Company

302 Grand Avenue, PO Box 39

Toll Free: 800-777-4498

Phone: 715-394-4444

E-mail: sales@dutchessbakers.com

Web: www.dutchessbakers.com

Model DUT/M140-W Floor Model Planetary Mixer

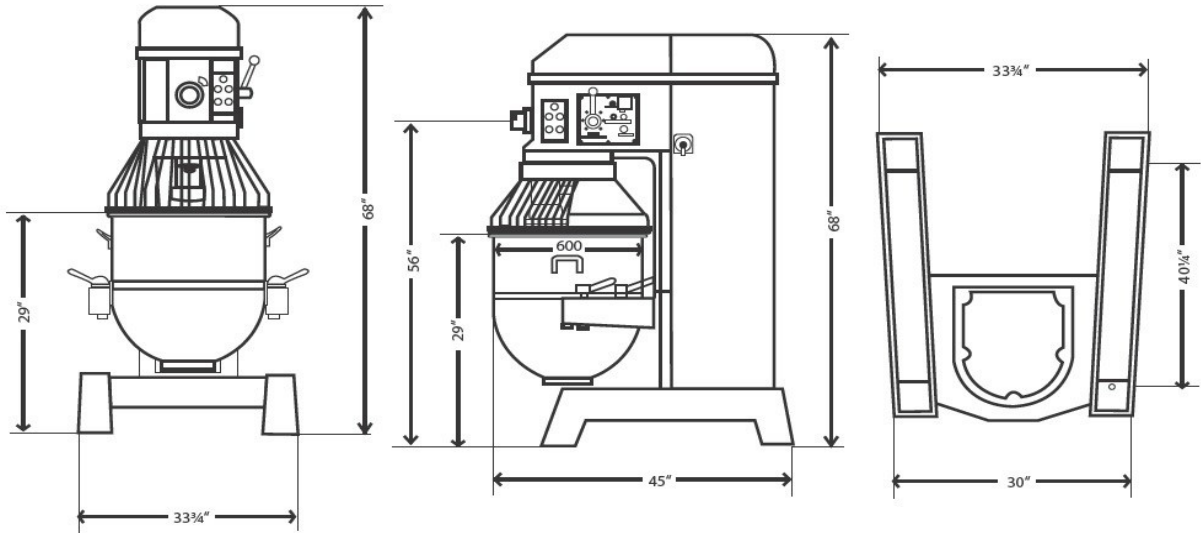

Electrical:

6 hp Heavy Duty Motor 208-240v / 60 hz / 3-phase, 16.3-Amp (1/2 hp Bowl Lift Motor)

Manual Reset Motor Overload - Auto Shut-Off when Bowl is Lowered or Bowl Guard Opened.

Dimensions:

33.75" Wide x 68" High x 45." Depth

Weight:

2204 lbs. Net Weight, 2645 lbs Shipping Weight.

Speed	Agitator RPM's
1	55
2	92
3	163
4	288

Warranty:

- ◆ 3-Year Limited Parts
- ◆ 1-Year Standard Parts and Labor