

SCS

Mobile Cashier's Counter

Project _____
 Item _____
 Quantity _____
 CSI Section 11400
 Approved _____
 Date _____

SCS: Mobile Cashier's Counter

Models

- SCS-30 30.00" (76cm) deep mobile cashier's counter
- SCS-36 36.00" (91cm) deep mobile cashier's counter
- SCS-50 50.00" (127cm) deep mobile cashier's counter



SCS-30
Shown with stainless steel fold-down tray slide and convenience outlet with breaker

Standard Features

- 18-gauge stainless steel exterior body
- 14-gauge galvanized bottom
- 14-gauge stainless steel top
- All exterior panels reinforced with overlapping corners, welded in place
- All body cutouts reinforced with 14-gauge channel supports
- All units are standard on 5" diameter polyurethane swivel casters for easy cleaning
- Easy to use stainless steel interlock system is standard on base and tray slides
- A 3" grommet hole is located at the rear of the top to allow cord access for cash registers
- Stainless steel locking cash drawer standard
- Stainless steel under shelf can serve as foot rest or storage
- One year parts and 90 day labor warranty

Options & Accessories

- Stainless steel fold-down tray slide
- Three-bar fold-down tray slide
- Composite fold-down cutting boards
- Stainless steel fold-down work shelf
- Line-up interlock device
- 120V/60Hz/1Ø, 10 amp convenience outlet with breaker*
- Stainless steel trim strips
- Stainless steel end drop shelf
- Adjustable height casters
- 6" (15cm) high adjustable stainless steel legs in lieu of casters
- Laminate exterior panels in lieu of stainless steel exterior panels

* Inclusion of these options will alter the electrical specifications of unit

Specifications

Exterior body is constructed of 18-gauge stainless steel side panels and 14-gauge galvanized bottom. All exterior side panels are reinforced with overlapping corners and are welded in place. All body cutouts are reinforced with 14-gauge galvanized channel supports.

Interior Lining at the cashier's end is 18-gauge stainless steel, with a stainless steel bottom shelf. Unit has an 16.50" x 16.50" x 5.00" (42cm x 42cm x 13cm) stainless steel cash drawer with lock and key.

Exterior top is constructed of 14-gauge stainless steel, welded, ground and polished into one integral unit. Top is fabricated with square exterior corners. A 2.00" (5cm) ferruled hole is located at the rear of the top to allow cord access for cash registers.

Castors; unit is mounted on 5.00" (13cm) diameter swivel casters with non-marking polyolefin tires and plate brakes. Overall height of caster assembly is 6.00" (15cm).



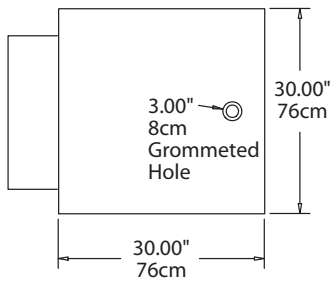

Plan View
SCS-30

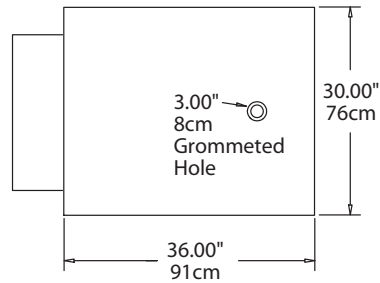

Plan View
SCS-36

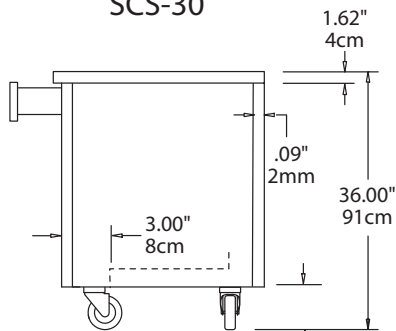

End View
SCS-30

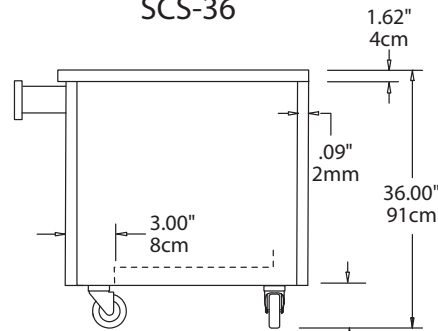

End View
SCS-36

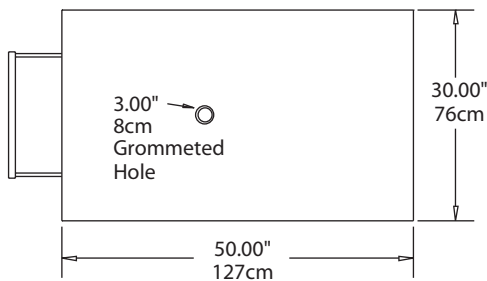

Plan View
SCS-50

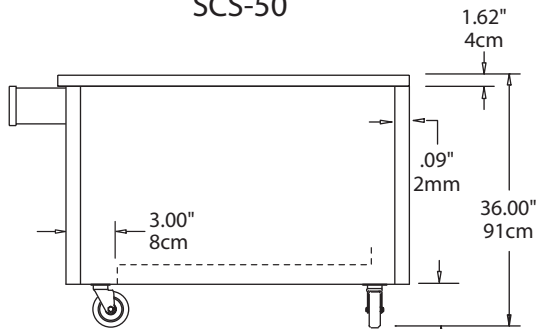

End View
SCS-50

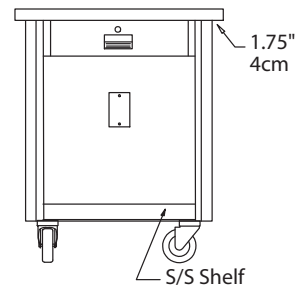

Elevation View
All Models

| Specifications | |
|----------------|------------------|
| Model | Ship Weight |
| SCS-30 | 180 lbs / 82 kg |
| SCS-36 | 210 lbs / 95 kg |
| SCS-50 | 270 lbs / 122 kg |

Mobile Cashier's Counter

SCS

Delfield reserves the right to make changes to the design or specifications without prior notice.