



Sliding Glass Doors



VR-33-SD-HC

Height 78.00"
 Length 39.50"
 Depth 29.75"
 Cubic Ft. 33
 Liters 934
 Bottles (20 oz) . . 504
 Cans (12oz) 840



VR-45-SD-HC

Height 78.00"
 Length 51.00"
 Depth 29.75"
 Cubic Ft. 45
 Liters 1,274
 Bottles (20 oz) . . 560
 Cans (12oz) . . 1,260



VR-67-SD-2U

Height 78.00"
 Length 73.20"
 Depth 29.75"
 Cubic Ft. 67
 Liters 1,897
 Bottles (20 oz) . . 790
 Cans (12oz) . . 1,926

Features

- Interior and exterior constructed of heavy duty white coated steel
- Polyurethane insulation with cyclopentane as blowing agent
- Stainless steel floors
- Illuminated top header sign
- Double pane glass door with Low-E protection
- New hanging door system with metallic rollers and magnetic seal featuring a stay open position
- Recessed door handle
- Heavy duty shelves with clips
- Forced air evaporator for rapid temperature "Pull Down"
- Self contained heavy duty 134a condensing unit
- Energy efficient LED lighting
- UL Classified to ANSI/NSF 7

Model No.	Description	Voltage	Amps	Temp	HP	Est. Ship Weight
VR-33-SD-HC	2 Door/8 Shelves	115	7.9	32°F - 39°F	1/3	420#
VR-45-SD-HC	2 Door/8 Shelves	115	11.8	32°F - 39°F	1/2	574#
VR-67-SD-2U	3 Door/ 12 Shelves	115	13.3	32°F - 39°F	2 @ 1/3	766#





Technical Data / Sliding Glass Doors

Model #	VR-33-SD-HC	VR-45-SD-HC	VR-67-SD-2U
Outside Dimensions			
Depth	29.75"	29.75"	29.75"
Length	39.50"	51.00"	73.20"
Height	78.00"	78.00"	78.00"
Door Size	17.81" x 51.69"	23.56" x 51.69"	23.56" x 51.44"
Door Type	2 sliding	2 sliding	3 sliding
Inside Dimensions			
Depth	22.50"	22.50"	22.50"
Length	36"	47.25"	69.69"
Height	61.625"	61.625"	61.625"
Shelf Size	20.50" x 17.25"	20.50" x 23.00"	20.50" x 21.00"
# of Shelves	6	8	12
Capacity: Cubic Foot	33	45	67
Specifications			
Operating Temperature	32°F-39°F	32°F-39°F	32°F-39°F
Refrigerant	134a	134a	134a
Compressor Size HP	1/3	1/2	2 @ 1/3
Voltage	115	115	115
Amperage	7.9	11.8	13.3
Cord and Plug	yes	yes	yes
Shipping Dimensions			
Depth	34.00"	34.00"	34.00"
Length	44.00"	55"	78.00"
Height	85.00"	85.00"	85.00"
Gross Weight lbs.	420	574	766
Cubic feet	73	95	130

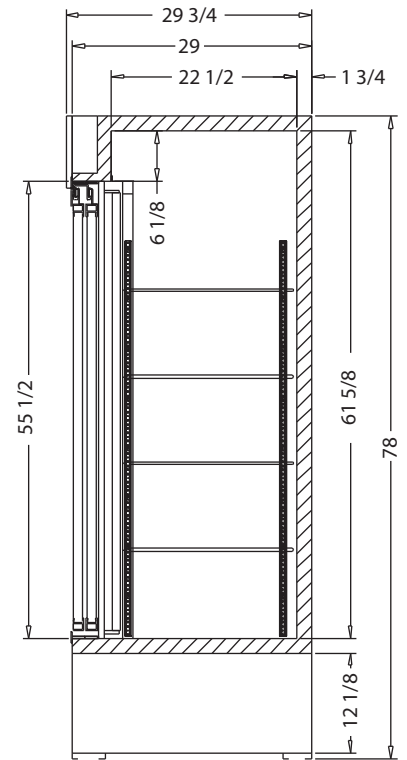

- Cases are designed to operate at 75°F and 55% relative humidity.
- Specification subject to change without notice.

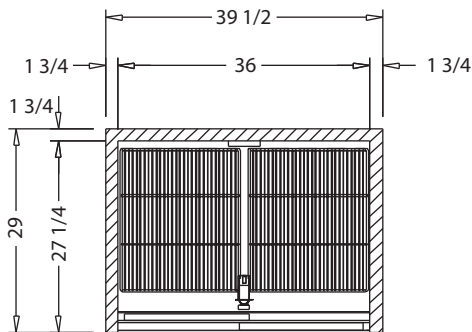

VR-33-SD-HC

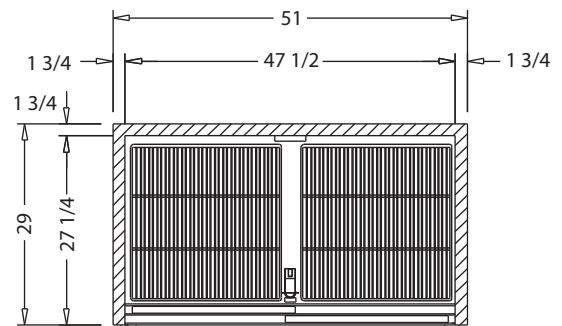

VR-45-SD-HC

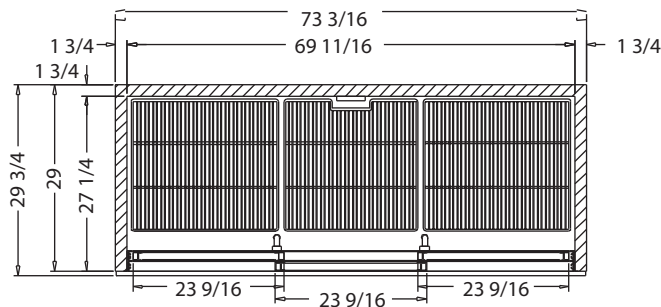

VR-67-SD-2U

