



VALPRO COMMERCIAL REFRIGERATION

203 Kelsey Ln., Building G
Tampa, FL 33619
813-502-0300
Toll Free 1-888-VALPRO-8
www.ValproRefrigeration.com
sales@ValproRefrigeration.com

PROJECT:	
MODEL #:	
ITEM #:	QTY:
AVAILABLE W/H:	
APPROVAL:	

HORIZONTAL BOTTLE COOLER 95"

MODEL:

VPB95

We are proud to introduce the beautifully constructed **Valpro VPB95 commercial horizontal 95" bottle cooler**. Keeping beverages cold and accessible is easy with our 95" bottle cooler manufactured with uncompromising quality, energy efficient technology, and standard premium features built in. This model will provide many years of worry free service and deliver cost saving eco-friendly energy efficiency with more affordable operating cost. This unit utilizes an over-sized balanced refrigeration system allowing fast beverage cooling and shorter run times in a busy commercial environment. All our bar refrigeration equipment utilize natural hydrocarbon refrigerant as an environmentally responsible choice having low global warming potential and no potential for ozone depletion. All Valpro products are manufactured under strict ISO9001 standards for quality assurance, and to consistently deliver to our customers products that satisfy all expectations. All our products are operated, extensively monitored, and undergo rigorous inspection prior to packaging and shipping.



* Compressor warranty 2 year parts & labor / 3 additional year warranty compressor part only

FEATURES

- All stainless steel interior and stainless steel framework
- Efficient LED interior lighting
- Stainless steel easy glide lids with locks for each lid
- Stainless steel countertop with integrated glass stops
- Black corrosion resistant steel exterior
- Bottle cap opener with cap catcher
- 5 heavy-duty, epoxy coated wire bin dividers adjustable to maximize storage
- Front mounted electronic thermostat digitally controlled temperature system maintains optimum beverage temperature with LED display
- Forced air fast cooling
- Four casters (standard) make it easy to maneuver and clean underneath
- High density 1.6" foamed in-place CFC free polyurethane insulation
- Over sized balanced refrigeration system uses environmentally friendly R290 hydrocarbon refrigerant
- Side mounted front accessible condensing unit for easy cleaning
- Large evaporator coil balanced with high horsepower compressor and large condenser provide better reliability and performance.
- ECM fans motor provide improved efficiency
- ETL sanitary certified and to NSF Standard 7



Model:
VPB95

95" Horizontal Bottle Cooler

Three Sliding Lids - 26 cu. ft. Capacity

Technical Data

Dimensional Data

Exterior Dimensions	95.3"W x 27"D x 35"H
Interior Dimensions	91.2"W x 23"D x 17.1"H 75"W x 23"D x 11.4"H
Net Storage Capacity	26 cu. ft.
Product Capacity	12oz btls/cans (39/55.5 cases)
Crated Weight	439 lbs.
Shipping Dimensions	98"W x 29.1"D x 41.3"H

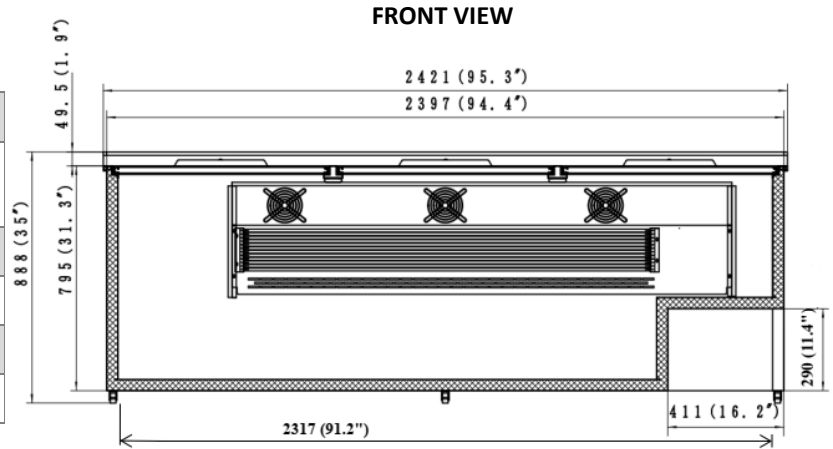

Refrigeration Data

Temperature Range	33°F - 41°F
Refrigerant	R-290
Refrigerating System	Capillary Tube
Temperature Controller	Digital
Horsepower	1/2

PLAN VIEW

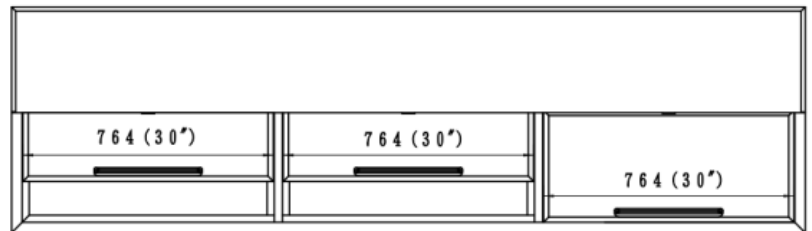

Construction Data

Exterior Material	Black Coated Steel
Interior Floor Material	304 Stainless Steel
Interior Wall Material	304 Stainless Steel
Insulation	1.6" CFC Free Polyurethane
Shelves (Wire Dividers)	5 Heavy Duty Epoxy Coated

Electrical Data

Interior Lighting	Efficient LED
Amps	3.3
Voltage/Frequency/Phase	115V/60Hz/1
Plug Type	NEMA 5-15P
Electrical Cord Length	9 ft.

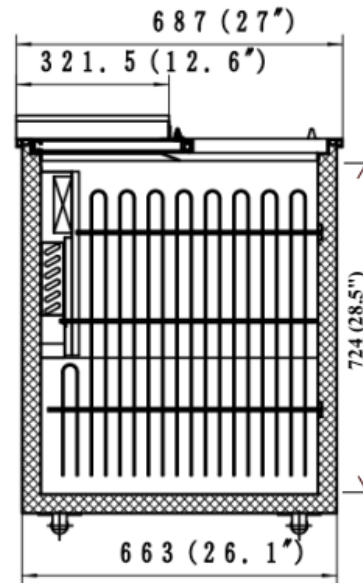

SIDE VIEW

Due to periodic changes in design, the specifications contained in this document are subject to change without notification.



Valpro Commercial Refrigeration
203 Kelsey Ln., Building G
Tampa, FL 33634



Tel: 813-502-0300
1-888-VALPRO-8
www.valprorefrigeration.com