

Blueair by BLUENIX

MODEL BLUI-100A ICE MACHINE UNDERCOUNTER



Produces up to 91 lbs of ice daily

Units produce individual crescent ice cubes.



Durable stainless steel cabinet and evaporator

with removable air filter.



Easy cleaning system

How to disassemble for cleaning
follow this youtube link:
<https://www.youtube.com/watch?v=HlkQ6RK87Nc>



Digital Self Diagnostic System

Power switch is accessible without
panel removal

**3 YEAR
WARRANTY**

PARTS & LABOR

**5 YEAR
WARRANTY**

COMPRESSOR & EVAPORATOR

Valid in the Continental United States

Service

- Panels easily remove and all components accessible for service
- Removable/cleanable air filters
- Allow 6" (15 cm) clearance at rear, sides, and top for proper air circulation and ease of maintenance/service

Plumbing

- Icemaker Water Supply Line: Minimum 3/8" Nominal ID Copper Water Tubing or Equivalent
- Icemaker Drain Line: Minimum 3/4" Nominal ID Hard Pipe or Equivalent

Cube Dimensions

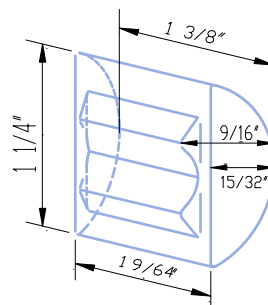

Approximate Size in inches,
image not to scale.

Front view

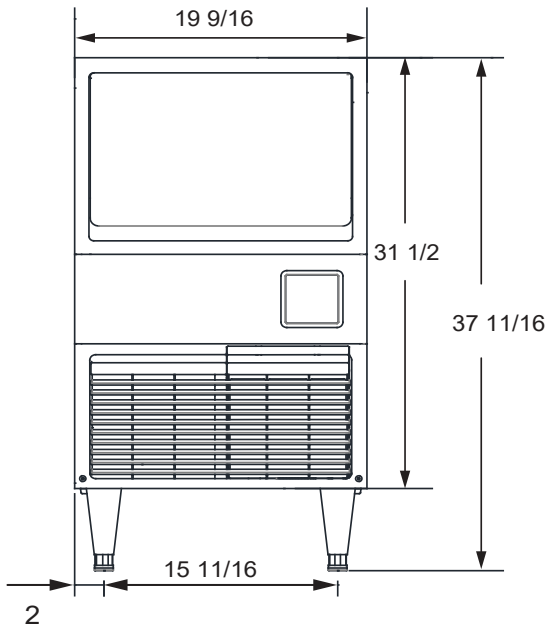

Side view

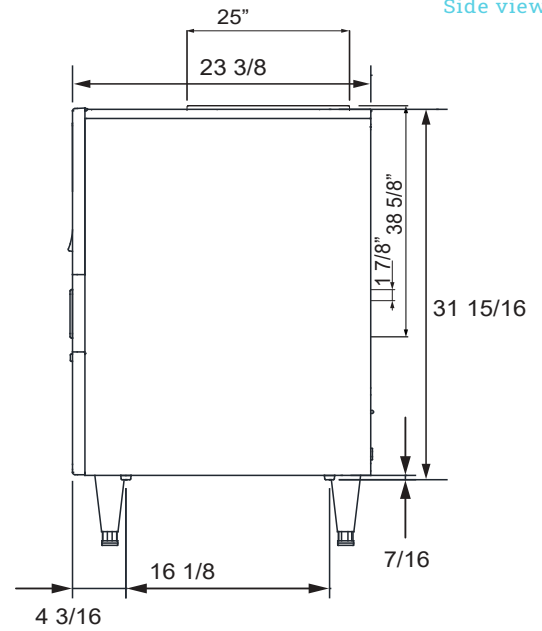

Blueair by
BLUENIX

Top view

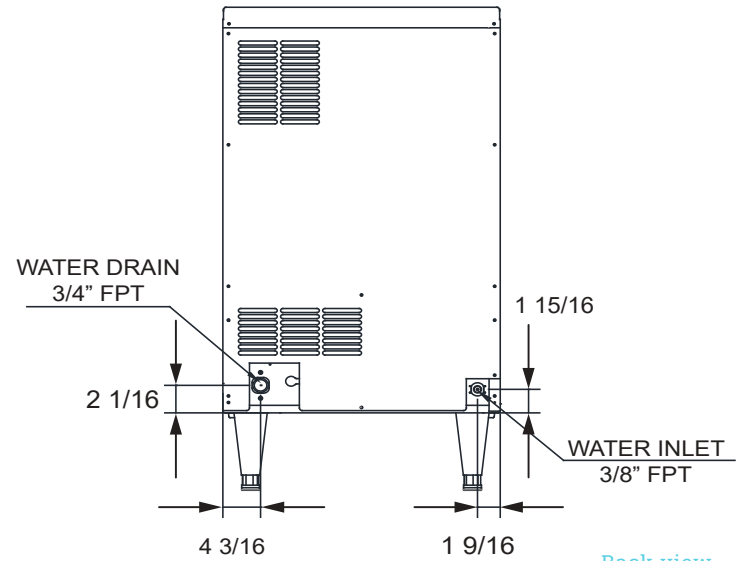
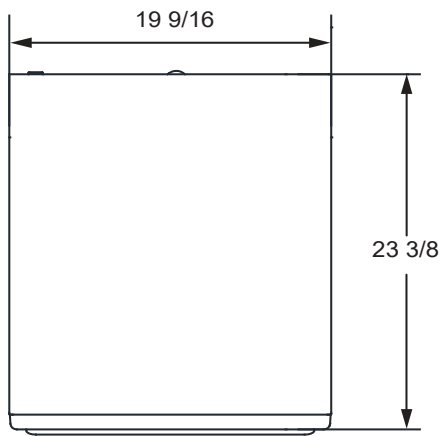

Back view

Ice Production

**Air / Water Temp
Lbs. per 24 hrs**

70°/50°F	90°/70°F
97lbs	79lbs

Per Cycle

Lbs	Cubes
1.97lbs	1,440

Air 90°F / Water 70°F

KWH
per 100 lbs.
10.02 kWh

Portable Water Gal.
per 100lbs
22.8 gal

Condenser	Air-Cooled
Amperage	5.2A
Voltage V/HZ/PH	115V/60/1
Shipping Weight	126 lbs / 57.5 kg
Refrigerant	R-134A
Ice storage	55lbs

Operating Limits

- Ambient Temp Range: 45 - 100° F
- Water Temp Range: 45 - 90° F
- Water Pressure: 10 - 100 PSIG
- Voltage Range: 100 - 130V

BLUE AIR has right to change specifications without further notice.



This product may expose you to chemicals including Diisononyl Phthalate(DINP), which is known to the State of California to cause cancer. For more information go to www.P65Warnings.ca.gov.



blueairfse.com



orders@blueairfse.com



1.886.677.8500



223 W. Rosecrans Ave., CA 90248
T: 310.808.0102

9 W. Shelton Terrace #A, Hillside, NJ 07205
T: 908-688-0970