

SPECIFICATION SHEET

CNH12ULP | CRISP 'N HOLD

HEATED FRIED FOOD HOLDING STATION. DOUBLE WALL INSULATED STAINLESS STEEL CONSTRUCTION WITH 1/2" WRAP-AROUND FIBERGLASS INSULATION. ON/OFF TOGGLE SWITCH. FACTORY PRE-SET FOR 190°F(88°C). FORCED AIR HEATING THROUGHOUT. REMOVABLE FOOD GRATE WITH AIR CIRCULATION HOLES AND EMBOSSED SURFACE. REMOVABLE CRUMB PAN. CNH12ULP ELECTRICAL CONFIGURATION: 120V, 1400 WATTS, 11.8 AMPS, 60HZ, SINGLE PHASE. SIX FOOT POWER CORD WITH NEMA 5-15P PLUG.





PROJECT
ITEM NO.
NOTES
MODEL NUMBER: CNH12ULP



FEATURES & BENEFITS

<input type="checkbox"/> DUAL-SIDED ACCESS AND COMPACT FOOTPRINT WITH ULTRA-LOW PROFILE	EASY TO FIT IN SMALL SPACES
<input type="checkbox"/> FACTORY PRE-SET TEMPERATURE OF 190°F (88°C)	HOLDS FOOD TO IDEAL HOLDING TEMPERATURE QUICKLY & EFFICIENTLY TO EXTEND HOLD TIMES AND PRODUCT QUALITY
<input type="checkbox"/> MECHANICAL THERMOSTAT WITH RANGE OF 90° TO 190°F (32° TO 88° C). PREHEAT TO 190°F (74°C) IN 30 MINUTES	GIVES OPERATOR FLEXIBILITY IN MENU OFFERINGS AND HOLDING TEMPERATURES
<input type="checkbox"/> FORCED AIR HEATING SYSTEM WITH ENGINEERED DUCTING THROUGH THE GRATE TO THE FOOD	EVENLY DISTRIBUTES HEAT THROUGHOUT FOOD PRODUCT
<input type="checkbox"/> STAINLESS STEEL, LIFT-OUT, FOOD GRATE WITH EMBOSSED SURFACE	ACTS AS A LIFT TO MINIMIZE FOOD CONTACT WITH HOT BASE
<input type="checkbox"/> SANITARY STAINLESS STEEL CRUMB PAN	EASY TO REMOVE AND CLEAN INSIDE SINK OR DISHWASHER (CHLORIDE-FREE OR PHOSPHATE-FREE CLEANER)
<input type="checkbox"/> ELECTRICAL COMPONENTS LOCATED AWAY FROM DUST AND VAPORS	PROTECTS ELECTRICAL COMPONENTS AND INCREASES POTENTIAL LIFESPAN

OPTIONS & ACCESSORIES

CNH12ULP: 230V, 1400W, 6.1A (CE VOLATAGE)

CLEARANCES

The front, top and sides must remain open and unobstructed. Allow at least 2" for ventilation gap at the top, and all four sides of the cabinet. Do not place the cabinet below sources of debris and dust. The food bay must be open and unobstructed for proper filling and serving food. Cabinet must be placed on non-combustible surface.

LONG FORM DESCRIPTION

Fried food holding station provides a heated curtain of air to maintain proper fried food holding temperature and freshness. The air circulation brings fried food to holding temperature to keep it crisp and ready to serve for an extended time. Forced air is heated through an electric resistance heater and ducted through a food grate. It travels through small openings in the grate to provide a warm blanket of air over and through the food. The grate is embossed to minimize hot metal contact with the food. It features dual-sided access with lift out food bay and crumb pan for easy cleaning.

WARRANTY

ONE YEAR LABOR PARTS & LABOR LIMITED WARRANTY

CONSTRUCTION

<input type="checkbox"/> FULL STAINLESS STEEL CONSTRUCTION
<input type="checkbox"/> 1/2" FIBERGLASS WRAP-AROUND INSULATION
<input type="checkbox"/> RECESSED ON/OFF TOGGLE SWITCH
<input type="checkbox"/> SIX FOOT POWER CORD WITH GROUNDED PLUG: NEMA 5-15P

CE
AGENCY
PENDING



SPECIFICATIONS SUBJECT TO CHANGE WITHOUT NOTICE FOR PRODUCT IMPROVEMENT AND INNOVATION

KCL & REVIT DRAWINGS UPON REQUEST

REVISION B | 7/18/2024

CARTER-HOFFMANN
1551 MCCORMICK AVENUE, MUNDELEIN, ILLINOIS 60060

847.362.5500 | 800.323.9793

WWW.CARTER-HOFFMANN.COM





PROJECT
ITEM NO.
NOTES
MODEL NUMBER: CNH12ULP

CONFIGURATIONS

MODEL	UNIT OVERALL DIMENSIONS			PRODUCT WEIGHT lbs (kg)	VOLTS	WATTS	AMPS	PHASE	Hz	NEMA (6" CORD)
	HEIGHT in (mm)	DEPTH in (mm)	WIDTH in (mm)							
<input type="checkbox"/> CNH12ULP	8.86 (225)	30.12 (765)	12.64 (321)	47 (21)	120	1400	11.8	1	60	5-15P plug



DRAWINGS

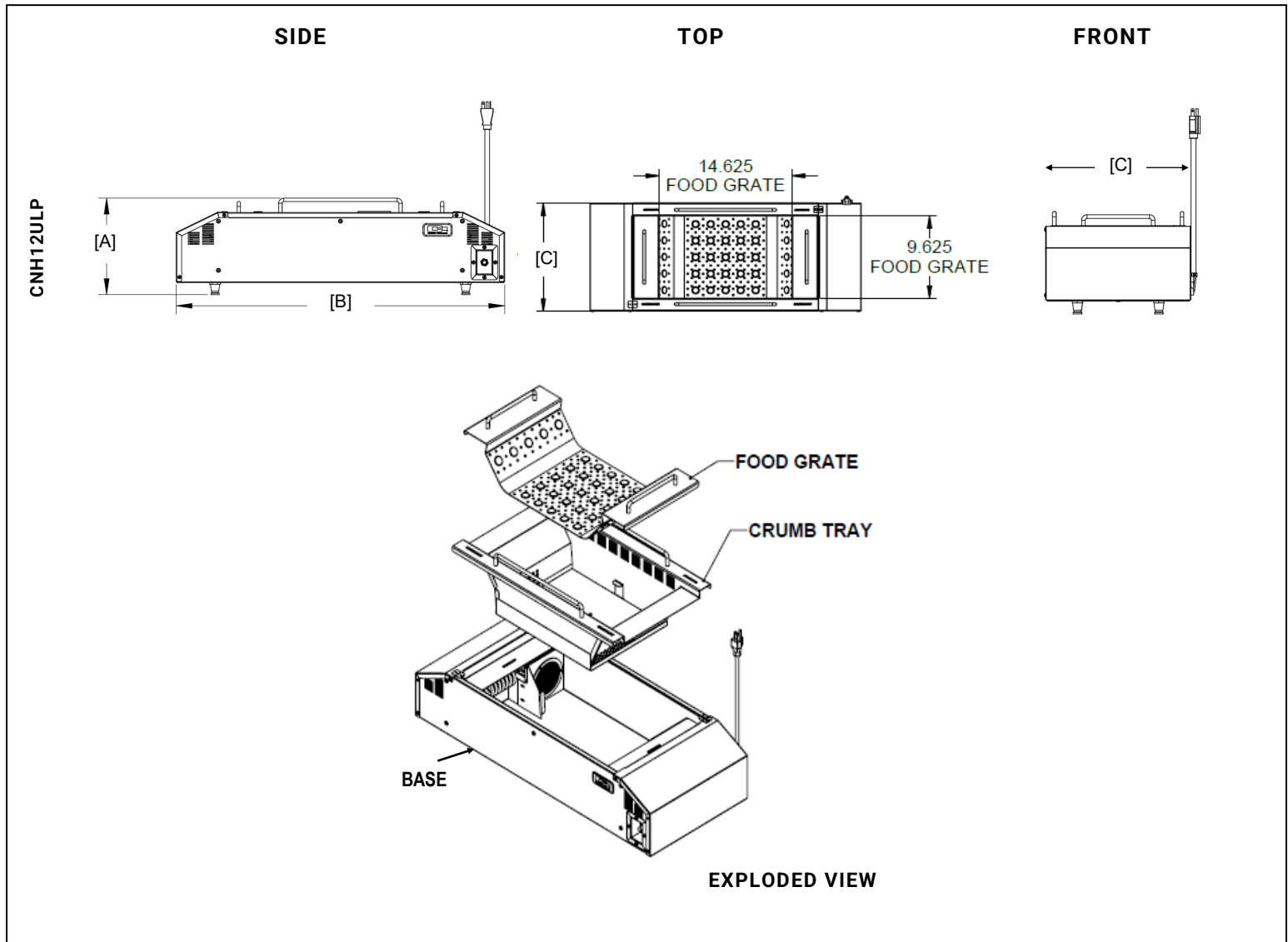

Due to periodic changes in designs, methods, procedures, policies and regulations, the specifications contained in this sheet are subject to change without notice. While Carter-Hoffmann exercises good faith efforts to provide information that is accurate, we are not responsible for errors or omissions in information provided or conclusions reached as a result of using these specifications. By using the information provided, the user assumes all risks in connection with such use.



SPECIFICATIONS SUBJECT TO CHANGE WITHOUT NOTICE FOR PRODUCT IMPROVEMENT AND INNOVATION

KCL & REVIT DRAWINGS UPON REQUEST

REVISION B | 7/18/2024

CARTER-HOFFMANN

1551 MCCORMICK AVENUE, MUNDELEIN, ILLINOIS 60060

847.362.5500 | 800.323.9793

WWW.CARTER-HOFFMANN.COM