



Project Name: _____

Location: _____

Item #: _____ Qty: _____

Model: _____

MIM250 / MIM265H SELF-CONTAINED ICE MACHINES

MODEL: MIM250 MIM265H



The MIM250 and MIM265H self-contained, air-cooled ice machines are perfect for bars, kitchens, or any application requiring high-volume ice-making capability. Each unit features a self-contained storage bin and a durable, easy to clean stainless steel and black plastic trim exterior. The easy-to-use controls, front-breathing design with vertical evaporator and proven ice making technology will deliver years of reliable ice production.

FEATURES AND CONSTRUCTION

- Stainless steel exterior with black plastic trim
- Air cooled compressor
- Programmable, solid state, digital electronic control system.
- Built-in self cleaning mode
- Automatic shut off / overflow protection
- Includes scoop
- Polyethylene storage bin liner for improved sanitation

DAILY ICE PRODUCTION

Air Temp 70°F (21°C) / Water Temp 50°F (10°C)

MIM250 260 lbs (118 kg)

MIM265H..... 265 lbs (120 kg)

Air Temp 90°F (32°C) / Water Temp 70°F (21°C)

MIM250 210 lbs (95 kg)

MIM265H..... 215 lbs (97.5 kg)

ICE BIN STORAGE CAPACITY

MIM250/265H 75 lbs (34 kg)

OPERATING REQUIREMENTS

Ambient Air Temperature Range..... 50° to 100°F (10° to 38°C)

Water Temperature Range 41° to 90°F (5° to 32°C)

Water Usage per 100 lbs of ice..... 21 Gallons (79L)

Water Supply Line Connection 3/8" FPT

Water Pressure Range:

Min PSI..... 15 Max PSI 80*

Min Bar 1.0 Max Bar..... 5.5

*Above 80 PSI requires a regulator

Energy Consumption per 100 lbs of ice:

MIM250 7.25 kWh/100 lbs

MIM265H..... 7.14 kWh/100 lbs

ELECTRIC

115V / 60Hz / 1Ph
(230V / 50-60Hz / 1Ph is available as an option)
6' (2m) NEMA 5-15P cord set included

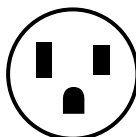

NEMA 5-15P

3RD PARTY APPROVALS



Certified to ANSI NSF 12



Certified to ANSI UL 563



DOE 2018 Compliant



Zero Ozone Depletion Potential

MAXX ICE WARRANTY (USA / CANADA)

Contact Maxx Ice for warranty statement at
TechnicalServices@TheLegacyCompanies.com or 877.368.2797



FRONT VIEW

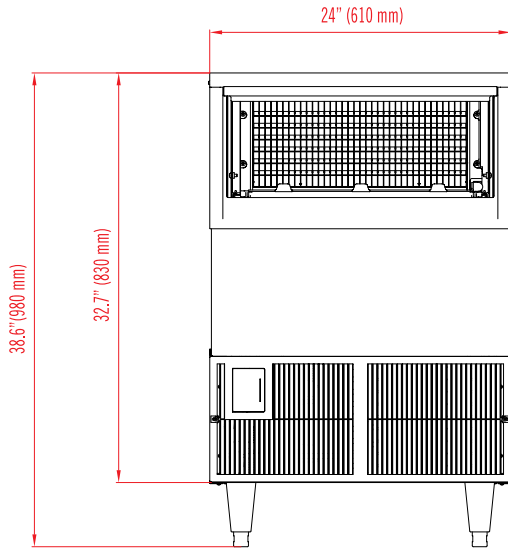

SIDE VIEW

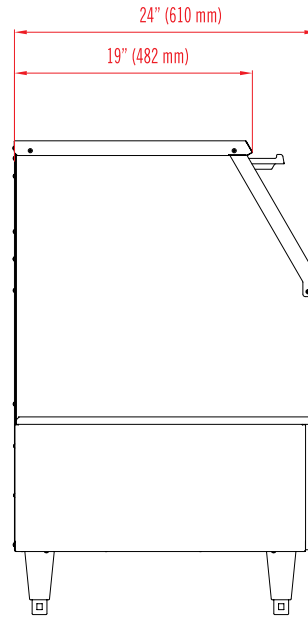

REAR VIEW

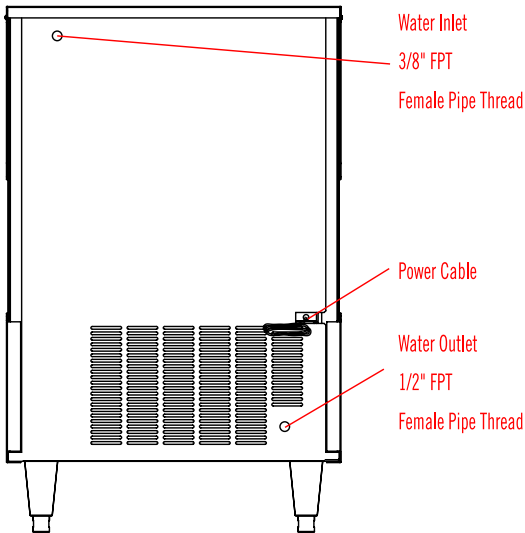

FULL DICE CUBE (MIM250)

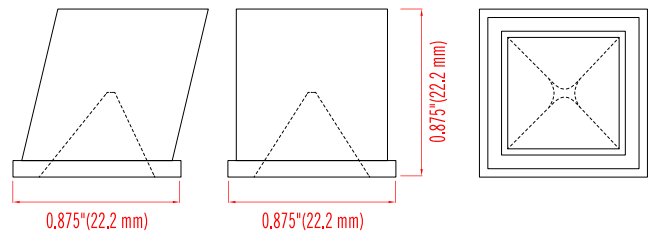

HALF DICE CUBE (MIM265H)

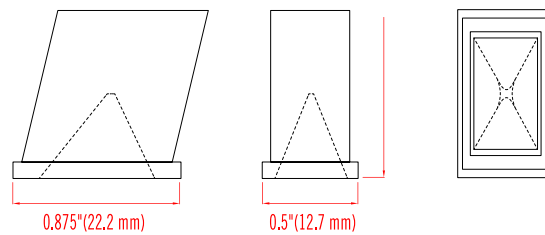

MODEL	EXTERNAL DIMENSIONS	DAILY ICE PRODUCTION (70°F Air / 50°F Water)	ICE BIN STORAGE CAPACITY	NET WEIGHT / SHIPPING WEIGHT	AMP DRAW (NOMINAL/MAX)	REFRIGERANT AND CHARGE SIZE	ELECTRICAL
MIM250	24" x 24" x 38.6" (610 x 610 x 980 mm)	260 lbs (118 kg)	75 lbs (34kg)	144 lbs (65 kg) 160 lbs (72.5 kg)	9.2A / 12A	R-404a 22.9oz (649g)	115V / 60Hz / 1Ph
MIM265H	24" x 24" x 38.6" (610 x 610 x 980 mm)	265 lbs (120 kg)	75 lbs (34kg)	144 lbs (65 kg) 160 lbs (72.5 kg)	9.2A / 12A	R-404a 22.9oz (649g)	115V / 60Hz / 1Ph

INSTALLATION

- A clearance of 2" from the wall is recommended to promote adequate cooling air circulation
- A gravity drain line is required to install this ice machine
- For optimal performance, the use of a water filter is recommended